

QUALIFICATIONS:

- UL 555 & CAN/ULC-S112 CLASSIFIED DYNAMIC FIRE DAMPER 1 1/2 hr. Label (File # R9492).
- California State Fire Marshal: Fire Damper Listing No. 3225-0935:101.
- Meets NFPA 80, 90A and 101 as well as IBC and NBC (Canada) Building Code requirements.
- Maximum velocity 3000 fpm @ 4" w.g.
- For use in vertical or horizontal concrete partitions and vertical steel stud partitions only.



APPLICATION:

Model 1201-DOW fire damper is specially designed for "out of wall" (vertical mount) or "out of floor" (horizontal mount) through penetration applications (ductwork is connected to both sides) where the damper cannot be installed within the plane of the wall or floor.

ITEMS:

- Ⓐ Duct/sleeve connection (See Note #4).
- Ⓑ Intumescent material (insulation).
- Ⓒ Retaining angles and fasteners (See Note #6).

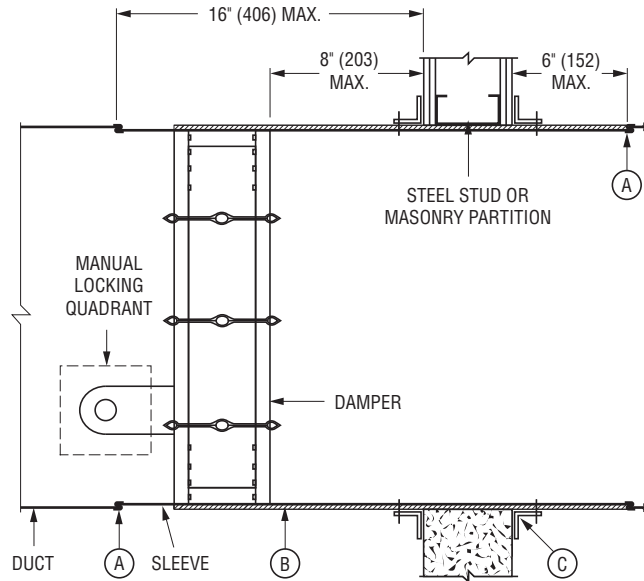

VERTICAL INSTALLATION

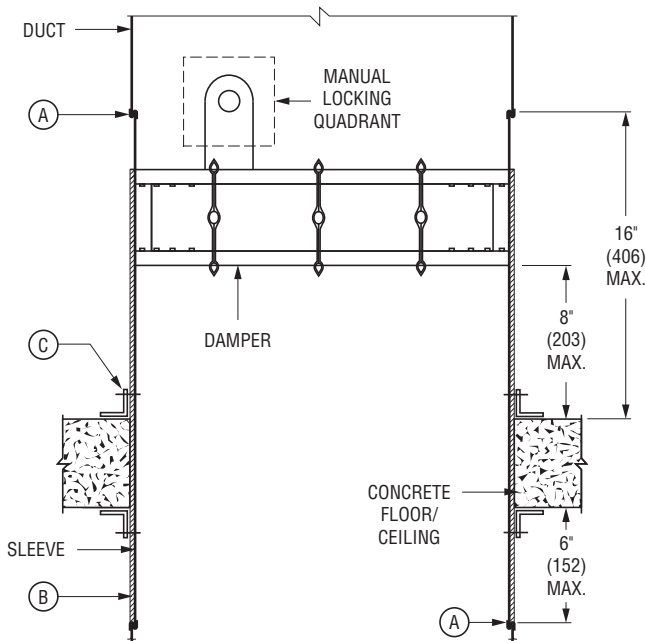

ABOVE FLOOR INSTALLATION

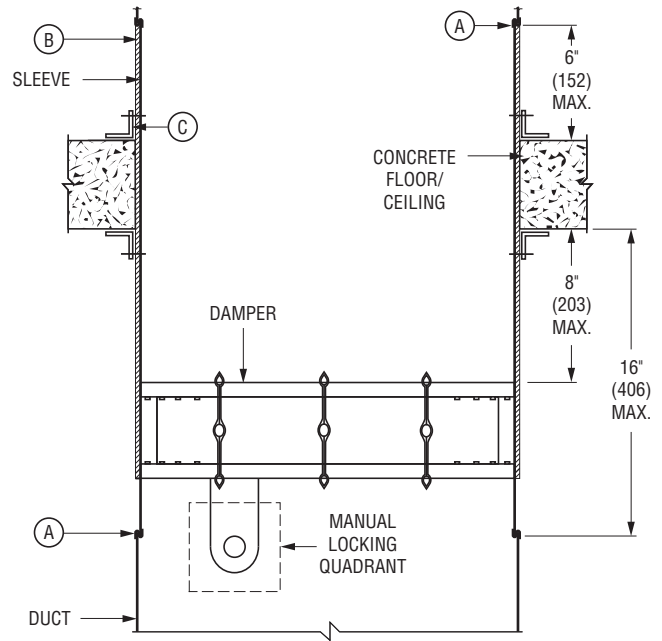

BELOW FLOOR INSTALLATION

NOTES:

1. Installation shall be in accordance with the appropriate requirements of the National Fire Protection Association Standard NFPA 90A latest edition.
2. **Damper Location Within Sleeve:** The maximum distance that the leading edge of the damper frame can be installed outside the wall or floor is as follows:
 Steel Stud or Masonry Walls: 8" (203).
 Concrete Floors: 8" (203).
3. **Damper Sleeve:** Factory furnished sleeves shall not be less than 20 gauge. (1.01) coated steel.
 Sleeve thickness must be equal to or thicker than the duct connected to it. Sleeve gauge requirements are listed in the SMACNA Fire, Smoke and Radiation Damper Installation Guide for HVAC Systems and in NFPA 90A. If a break-away style duct/sleeve connection is not used, damper sleeves up to 36" wide by 24" (914 x 610) high of not less than 16 gauge (1.61) coated steel, or larger sleeves of not less than 14 gauge (1.99) thick coated steel may be attached to the duct with screws or other types of mechanical fasteners. The maximum sleeve thickness for such rigid joints is 10 gauge (3.51) for coated steel.
 The connecting duct shall not be continuous thru the wall or floor opening but shall terminate at the sleeve. Sleeves shall extend a maximum of 16" (406) from the wall/floor on the damper/actuator side and maximum 6" (152) on the other side.
4. **Break-away duct/sleeve connections:**
 - a. Rectangular ducts must use one or more of the following connections if the gauge is less than the requirement in note 3 for rigid connections:

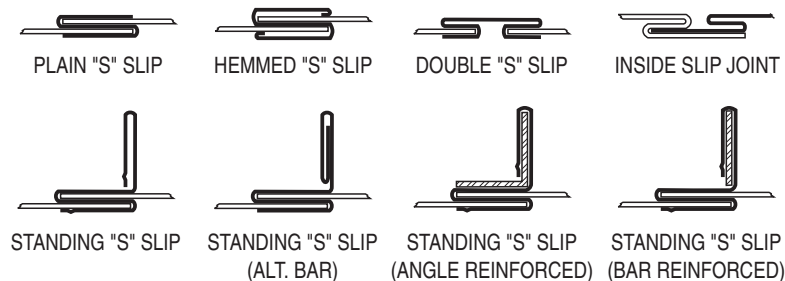

In addition:

- One of the above connections on the top and bottom joints with flat drive slip connections on the side joints may be used for dampers up to 20" (508) in height.



- A maximum of two #10 sheet metal screws on each side and on the bottom, located in the center of the slip pocket and penetrating both sides of the slip pocket may be used.
- b. Round or oval duct may be attached to the round or oval collar which is part of the damper/sleeve in the following manner:
 - Duct diameters 22" (559) and smaller may use three #10 sheet metal screws equally spaced around the circumference.
 - Duct diameters over 22" (559) up to and including 36" (914) may use five #10 sheet metal screws equally spaced around the circumference.
 - Duct diameters larger than 36" (914) high or diameter may use eight #10 sheet metal screws equally spaced around the circumference.
 - c. For the use of approved alternative Ductmate or TDC/TDF break-away connections, refer to the supplements noted on this page.
- Note:** When optional sealing of these break-away connections is desired, the duct sealant shall be PA2084T Duct Sealant by Precision or water based DP1010 by Design Polymetrics.
5. **Opening Size:** Expansion clearance is not required, however the opening size in partition should be sized 1/2" (13) larger than nominal damper size in all directions to allow for sleeve thickness and insulation.
 6. **Retaining Angles** shall be a minimum of 1 1/2" x 1 1/2" x 16 gauge (38 x 38 x 1.61). Secure the retaining angles to the sleeve with 1/2" (12.7) long welds, 1/4" (6.35) dia. bolts and nuts, 3/16" (4.76) dia. steel rivets or #8 sheet metal screws, 8" (203) on center and 2" (51) maximum from corner of sleeve on all four sides. The retaining angles must lap the structural opening by 1" (25.4) minimum. Field fabricated retaining angles are not to be mechanically fastened at the corners.
 7. **Maximum Size Limitations:** Vertical: 36" x 48" (914 x 1219), Horizontal: 32" x 48" (813 x 1219). Minimum size is 8" x 8" (203 x 203).
 8. **Actuator and Accessories:** Nailor multi-blade fire dampers are supplied with an internal locking quadrant as standard to hold damper blades in the open position. If MLS-300 position indicators are used, refer to the proper installation instructions for the MLS-300.

REFER TO THE APPROPRIATE NAILOR INSTALLATION INSTRUCTION SUPPLEMENTS FOR ADDITIONAL INFORMATION OR SPECIAL REQUIREMENTS:

MLS-300 (Nailor) POSITION INDICATOR	MLS3N
STEEL AND WOOD STUD FRAMING	FDSWSFINST
CAVITY SHAFT WALL PARTITIONS	FDCSWINST
FLANGED TYPE ALTERNATE BREAKAWAY CONNECTIONS	FDFABCINST
TDC/TDF FLANGED DUCT CONNECTION	FDTDCCINST
QUICK-SET RETAINING ANGLES	FDQSRA

Dimensions are in inches (mm).



Houston, Texas
 Tel: 281-590-1172
 Fax: 281-590-3086

Las Vegas, Nevada
 Tel: 702-648-5400
 Fax: 702-638-0400

Toronto, Canada
 Tel: 416-744-3300
 Fax: 416-744-3360

Calgary, Canada
 Tel: 403-279-8619
 Fax: 403-279-5035