

APPLICATION:

This vertical fire damper installation is for metal stud framing in UL resistant cavity shaft wall designs (1 and 2 hr.) including Nos. U438, U469 and U497. It differs from conventional fire damper installations in that it requires retaining angles on one side of the wall only, which are fastened to the wall as well as the damper for opening sizes up to 48" W x 36" H (1219 x 914). Larger openings require retaining angles on both sides.

GENERAL INSTALLATION:

- 1. Expansion Clearance:** Opening in wall shall be a minimum 1/8" (3) per linear foot larger than overall size of damper and sleeve assembly in either dimension. Maximum opening not to exceed 1/8" (3) per foot plus two inches. Opening shall not be less than 1/4" (6) larger for any size damper and sleeve assembly.
- 2. Damper Sleeve:** Sleeve gauge shall be at least equal to the gauge of the duct as defined by the appropriate SMACNA duct construction standard and described in NFPA 90A when one or more of the following duct-sleeve connections are used (TDC/TDF breakaway, ductmate breakaway, plain "S" slip, hemmed "S" slip, standing "S" slip, reinforced standing "S" slip, inside slip joint, and double "S" slip.)

In addition, the following connections are acceptable:

- A.** On rectangular duct, a standing S slip connection, with two #10 sheet metal screws on each side and bottom of the joint and with duct sealant* applied to each connection, may be used.
- B.** On rectangular duct, a standing S slip connection on top and bottom joints and flat drive connections on side joints with duct sealant* applied to each connection, may be used for dampers 48" x 20" (1219 x 508) and smaller. Plain S and hemmed S slip connections can also be used in lieu of the standing S connections described above.
- C.** A round duct may be attached to the round adapter which is part of the damper sleeve in the following manner:
 - (a) Duct diameters 22" (559) and smaller must use three #10 sheet metal screws equally spaced around the circumference and with duct sealant* applied to the connection.
 - (b) Duct diameters over 22" (559) up to and including 36" (914) may use five #10 sheet metal screws equally spaced around the circumference and with duct sealant* applied to the connection.
 - (c) Duct diameters larger than 36" (914) wide or diameter may use eight #10 sheet metal screws equally spaced around the circumference.

*The duct sealant must be PA2084T Duct Sealant Adhesive as manufactured by Precision or water based DP1010 by Design Polymetrics.

- 3.** If any other duct-sleeve connections are used, sleeve shall be minimum of 16 gauge (1.6) for dampers up to 36" w x 24"h (914 x 610) and 14 gauge (1.9) if damper width exceeds 36" (914) or height exceeds 24" (610).
- 4. Damper/Sleeve Attachment:** Damper shall be secured to sleeve with 1/4" (6) long welds, 3/16" (5) steel rivets, 1/4" (6) bolts and nuts, #8 sheet metal screws, or 3/16" (5) buttonlocks on both sides at 6" (152) on center and 2" (51) maximum from the corner of the damper on all four sides. For field assembled sleeves, the inner dimensions of the sleeve shall be equal to the outer dimensions of the damper.

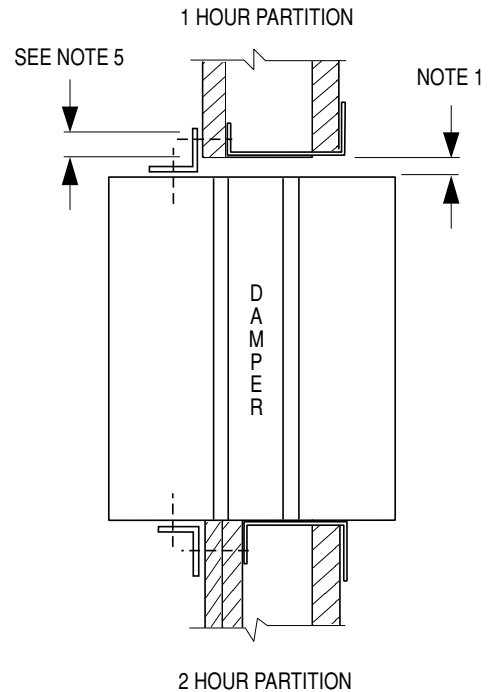

5. Retaining Angles:

- A.** Shall be a minimum of 1 1/2" x 1 1/2" x 16 gauge (38 x 38 x 1.61) and fastened with #10 bolts or screws, 1/2" (13) long welds, or 3/16" (5) rivets to sleeve at a maximum spacing of 8" (152) O.C. and not more than 2" (51) from each end with a minimum of two connections on each side, top and bottom (See Illustration).
Nailor 'Quick-Set' Retaining Angles can be used in lieu of conventional mounting angles. Retaining angles must overlap the structural opening by 1" (25) minimum.
- B.** Retaining angles screw to wall with #10 screws. Use a minimum of two fasteners per side, top and bottom 12" (305) O.C. maximum.

- 6.** See framing detail on next page for opening preparation. Refer to the appropriate installation supplements for the following requirements:

Ductmate Breakaway Connection	Doc. FDDMINST
Flange System Breakaway Connections	Doc. FDTDCFINST
'Quick-Set' Retaining Angles.	Doc. FDQSRA

- 7.** Refer to Underwriters Laboratories Inc. Fire Resistance Directory Vol. II for details on UL Design No. U438, U469 and U497.



**FRAMING DETAIL FOR ASSEMBLIES
(U438 AND U469)**

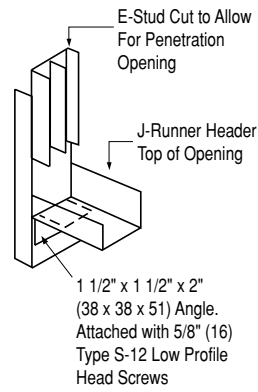
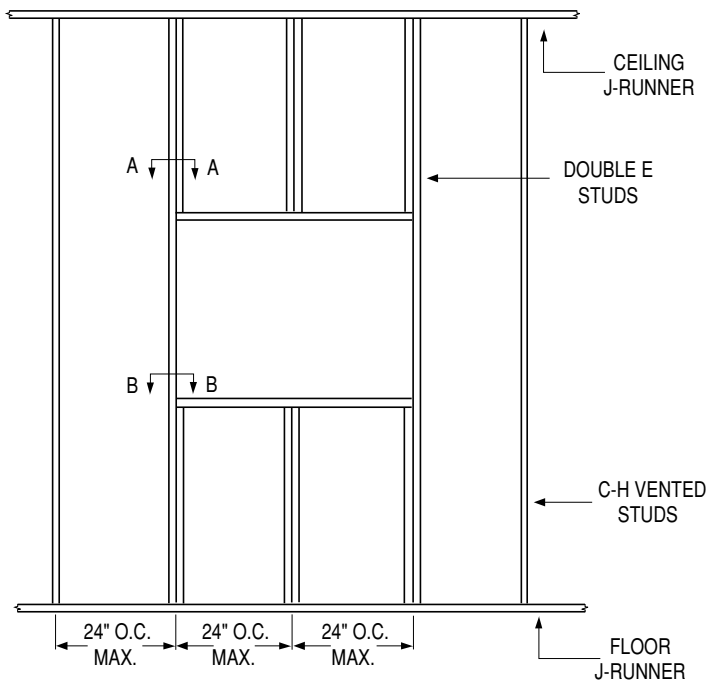

SECTION A-A

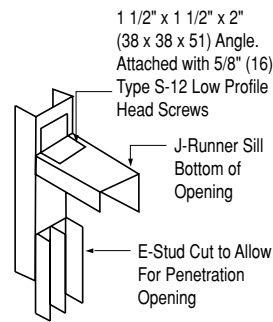

SECTION B-B

**FRAMING DETAIL FOR
ASSEMBLIES (U497)**

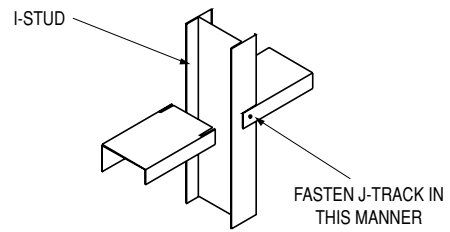
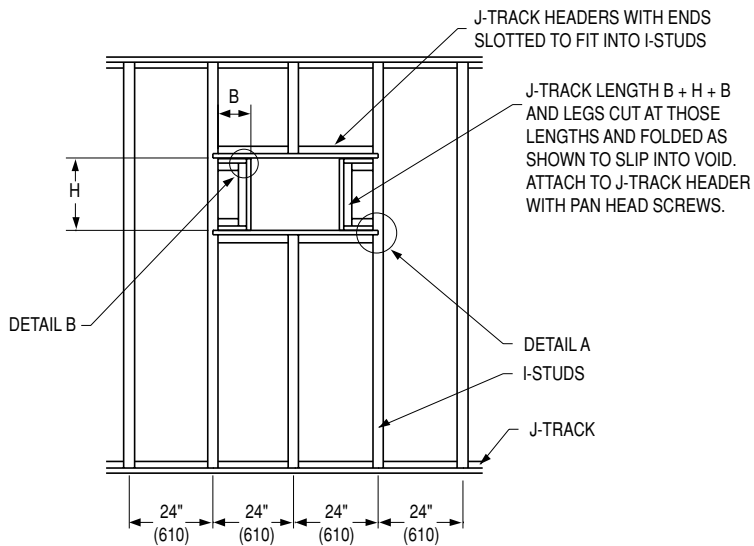

DETAIL A

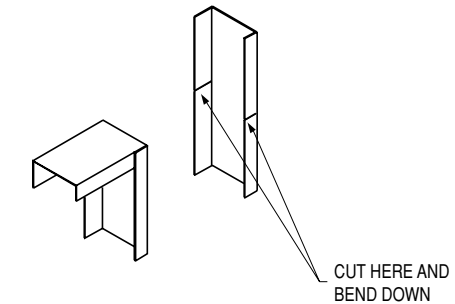

DETAIL B

Dimensions are in inches (mm).

Page 2 of 2



Houston, Texas
Tel: 281-590-1172
Fax: 281-590-3086

Las Vegas, Nevada
Tel: 702-648-5400
Fax: 702-638-0400

Toronto, Canada
Tel: 416-744-3300
Fax: 416-744-3360

Calgary, Canada
Tel: 403-279-8619
Fax: 403-279-5035