

# INSTALLATION INSTRUCTIONS

## STAINLESS STEEL MULTI-BLADE FIRE DAMPERS

### 1 1/2 HOUR LABEL • VERTICAL MOUNTING ONLY

### MODEL SERIES (D)1200-SS

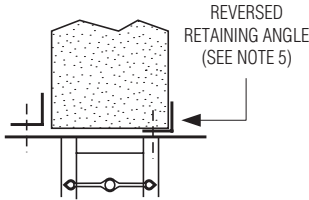

#### QUALIFICATIONS:

- **UL 555 & CAN/ULC-S112 CLASSIFIED FIRE DAMPER 1 1/2 hr. Label (File #'s R9492 & R19569).**
- **Meets NFPA 80, 90A and 101 as well as IBC & NBC (Canada) Building Code requirements.**

#### NOTES:

1. Installation shall be in accordance with the appropriate requirements of the National Fire Protection Association Standard NFPA 90A latest edition.
2. **Damper Sleeve:** Sleeve thickness must be equal to or thicker than the duct connected to it. Sleeve gauge requirements are listed in the SMACNA Fire, Smoke and Radiation Damper Installation Guide for HVAC Systems and in NFPA 90A. If a break-away style duct/sleeve connection is not used, damper sleeves up to 36" wide by 24" (914 x 610) high of not less than 16 gauge (1.61) galvanized or stainless steel, or larger sleeves of not less than 14 gauge (1.99) thick steel may be attached to the duct with screws or other types of mechanical fasteners. The maximum sleeve thickness for such rigid joints is 10 gauge (3.51).  
The connecting duct shall not be continuous thru the wall or floor opening but shall terminate at the sleeve. Sleeves shall extend a maximum of 6" (152) on either side of the wall or floor opening or 16" (406) on a side intended for use with an actuator and/or an access door. The sleeves may extend 16" (406) on each side for use with an actuator on one side and an access door on the other side.

#### 3. Break-away duct/sleeve connections:

- a. Rectangular ducts must use one or more of the following connections if the gauge is less than the requirement in note 2 for rigid connections:

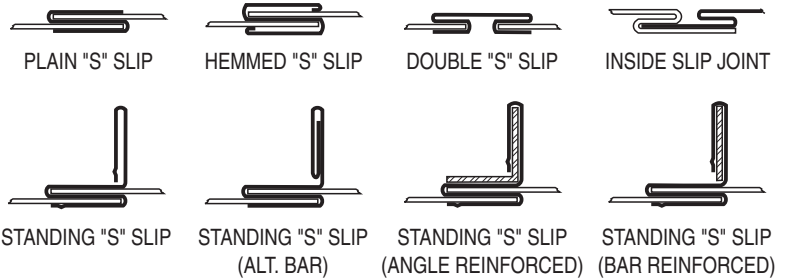

In addition:

- A maximum of two #10 sheet metal screws on each side and on the bottom, located in the center of the slip pocket and penetrating both sides of the slip pocket may be used.
- One of the above connections on the top and bottom joints with flat drive slip connections on the side joints may be used for dampers up to 20" (508) in height.



- b. Round or oval duct may be attached to the round or oval collar which is part of the damper/sleeve in the following manner:
  - Duct diameters 22" (559) and smaller must use three #10 sheet metal screws equally spaced around the circumference.
  - Duct diameters over 22" (559) up to and including 36" (914) may use five #10 sheet metal screws equally spaced around the circumference.
  - Duct diameters larger than 36" (914) wide or diameter may use eight #10 sheet metal screws equally spaced around the circumference.

**Note:** When optional sealing of these break-away connections is desired, the duct sealant shall be PA2084T Duct Sealant by Precision or water based DP1010 by Design Polymetrics.

- c. For the use of approved alternative Ductmate or TDC/TDF break-away connections, refer to the supplements noted on page 2.

4. **Damper/sleeve attachment:** Damper shall be secured to sleeve with 1/4" (6) long welds, 1/4" (6.35) dia. bolts and nuts or #10 sheet metal screws on both sides at 6" (152) on center and a maximum of 4" (102) from the corners of the damper on all four sides. For field assembled sleeves, the inner dimensions of the sleeve shall be equal to the outer dimensions of the damper.

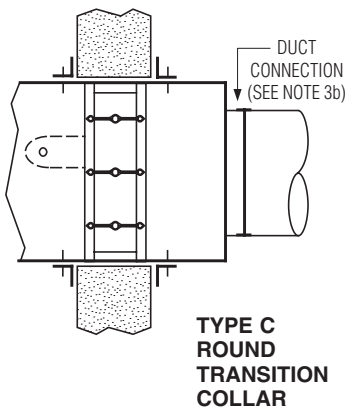
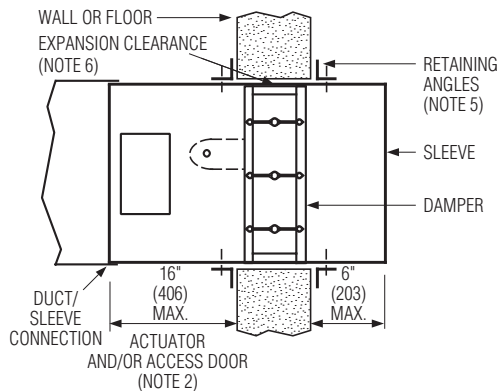

**WARNING: STRONG SPRING UNDER TENSION ON ALL UNITS, KEEP HANDS CLEAR. IN ALL INSTALLATIONS ENSURE THAT OPERATING DRIVE SHAFT IS FREE FROM OBSTRUCTION TO ENSURE EASE OF OPERATION.**

**5. Retaining angles** shall be a minimum of 1 1/2" x 1 1/2" x 16 gauge (38 x 38 x 1.61) steel for dampers up to 90" (2286) in width and up to 90" (2286) in height. For dampers exceeding these dimensions, the angles shall be a minimum of 2" x 2" x 10 gauge (51 x 51 x 3.51). Secure the retaining angles to the sleeve with 1/2" (12.7) long welds, 1/4" (6.35) dia. bolts and nuts or #10 sheet metal screws 8" (203) on center and 2" (51) maximum from corner of sleeve on all four sides. The retaining angles must lap the structural opening by 1" (25.4) minimum. When the ductwork terminates at the wall or floor, the retaining angles may be turned inwards, providing the opening size is increased by an amount equal to twice the combined thickness of the angle and the height of the screw or bolthead to maintain the required expansion clearance. Field fabricated retaining angles are not to be mechanically fastened at the corners.

**6. Expansion clearance** between the sleeve and wall or floor shall be a minimum of 1/8" per foot (3.18 per 305) of width or height of the sleeve. The maximum size of the opening shall be 2" (50.8) larger in either dimension than the allowable minimum size. For example; a sleeve dimension of 36" x 36" (914 x 914) shall have an opening size of 36 3/8" x 36 3/8" (924 x 924) minimum and 38 3/8" x 38 3/8" (975 x 975) maximum.

**7. Maximum Size Limitations:** The maximum Type A fire damper sizes are as follows:

Model Series			Single Section	Multiple Section
1200-SS (Static)	Vertical	(1 1/2 hr. label)	36" x 48" (914 x 1219)	144" x 96" (3658 x 2438)
D1200-SS (Dynamic)	Vertical	(1 1/2 hr. label)	36" x 48" (914 x 1219)	72" x 96" (1829 x 2438) or 144" x 48" (3658 x 1219)

Type B and C dampers have the same overall damper size but the connecting ducts are smaller due to the B or C enclosures. See Type B and Type C specification drawings for maximum duct sizes.

In cases when the openings are larger than specified in note 7, a UL tested and qualified steel mullion must be provided between assemblies (Refer to supplementary installation document FDSMINST). Mullion is for use in static applications only.

**8. Actuators and accessories:** Nailor multi-blade fire dampers are supplied with an internal locking quadrant as standard to hold damper blades in the open position. If MLS-300 position indicators are used, refer to the proper installation instructions for the MLS-300.

**9. Multiple-section assemblies:** In multiple assemblies of vertical dampers, the frames shall be joined together on both sides of the damper using 1/4" (6) long welds, 1/4" (6.35) dia. bolts and nuts, or #8 sheet metal screws. Maximum 6" (152) on center.

Multiple section vertical damper assemblies, over two sections wide, require a 10 ga. (3.51) x 5" (127) flat vertical mullion between one pair of sections (see Figure 1). When a minimum 16 ga. (1.6) sleeve is used and a left and right section are sleeved separately, the sleeve acts as the mullion, therefore no mullion is required. The sleeves shall be joined together on both sides of the damper using 1/4" (6) long welds, 1/4" (6.35) dia. bolts and nuts or #8 sheet metal screws. Maximum 6" (152) on center (see Figure 2).

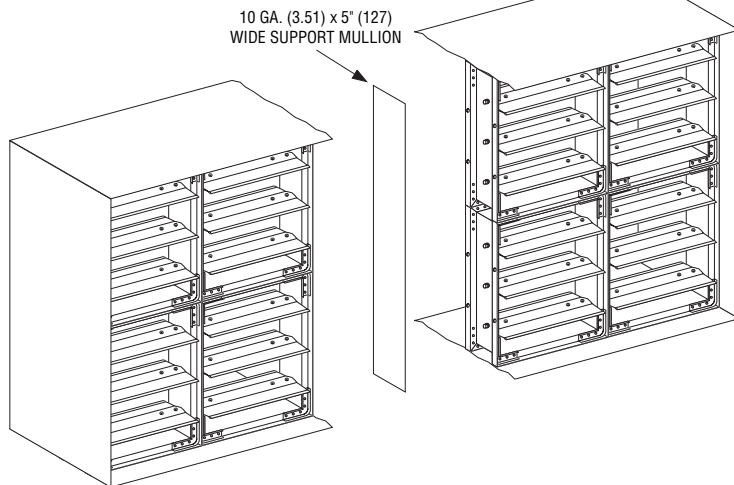

Figure 1. Single sleeve around outside and vertical mullion

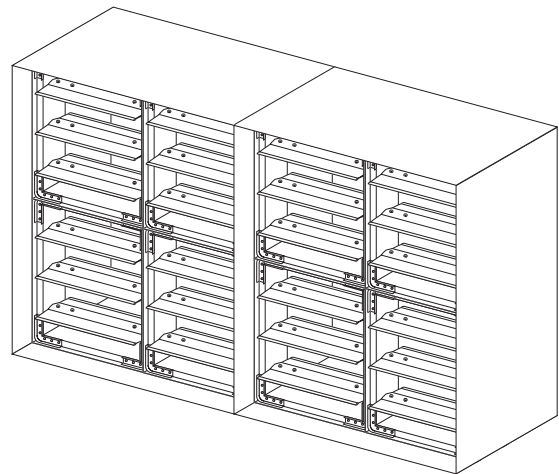

Figure 2. Two individually sleeved units (No mullion required)

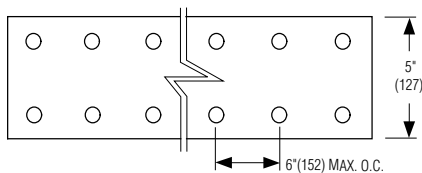

Figure 3. Flat Mullion

**IMPORTANT:**

- DO NOT CAST DAMPER IN PLACE.
- DO NOT FASTEN RETAINING ANGLES OR DAMPER DIRECTLY TO WALL OR FLOOR.
- DO NOT INSTALL DAMPER OUT OF SQUARE OR OUT OF FLAT.
- VERTICAL MOUNTING SHOWN ON MASONRY WALL.
- FOR INSTALLATION IN DRYWALL FRAMING, SEE DOC. FDSWSFINST.

Dimensions are in inches (mm).

**REFER TO THE APPROPRIATE NAILOR INSTALLATION INSTRUCTION SUPPLEMENTS FOR THE FOLLOWING SPECIAL REQUIREMENTS:**

- |   |            |
|---|------------|
| STEEL MULLIONS (for dampers in oversized wall openings) | FDSMINST   |
| SINGLE SIDED RETAINING ANGLES                           | FDSSRAINST |
| STEEL AND WOOD STUD FRAMING                             | FDSWSFINST |
| CAVITY SHAFT WALL PARTITIONS                            | FDCSWINST  |
| DUCTMATE BREAKAWAY CONNECTIONS                          | FDDMINST   |
| TDC/TDF FLANGED DUCT CONNECTION                         | FDTDCFINST |
| QUICK-SET RETAINING ANGLES                              | FQDSRA     |



Houston, Texas  
Tel: 281-590-1172  
Fax: 281-590-3086

Las Vegas, Nevada  
Tel: 702-648-5400  
Fax: 702-638-0400

Toronto, Canada  
Tel: 416-744-3300  
Fax: 416-744-3360

Calgary, Canada  
Tel: 403-279-8619  
Fax: 403-279-5035