

REVIEW FIGURE 1. IF YOUR EPIC CARD LOOKS LIKE THIS, USE THESE INSTRUCTIONS. IF YOUR EPIC FAN VOLUME CONTROLLER CARD LOOKS DIFFERENT, REFER TO IOM-ECM-A.

**NOTICE:**

**POWER MUST BE REMOVED FROM THE CONTROLLER WHENEVER CONNECTIONS OR DISCONNECTIONS ARE BEING MADE. FAILURE TO DO SO COULD RESULT IN IRREPARABLE DAMAGE.**

**BEFORE PROCEEDING WITH ANY ADDITIONAL TROUBLESHOOTING, ENSURE THAT THE POLARITY OF THE 24 VAC SUPPLY TO THE CONTROLLER IS CORRECT. (SEE FIGURE 1). IF THE POLARITY IS NOT CORRECT, REMOVE THE CONNECTORS AND RECONNECT OBSERVING PROPER POLARITY. RECHECK THE SYSTEM FOR PROPER OPERATION.**

1. With power off, inspect the unit to make sure that there are no foreign objects blocking fan operation. Turn the blower wheel by hand to verify that it moves freely.
2. Energize the unit at the disconnect switch. Adjust the controls to call for the fan motor to run.

### LED Indicator

The ECM card provides a visual airflow indicator. A green LED located on the controller circuit board flashes in response to the airflow indicator pulses provided by the control board located in the motor. Each pulse is 100 cfm (47.2 l/s). The last pulse is scaled.

### Setting the Fan Airflow in the Manual Mode

1. Mode Selector Jumper must be in the "MAN" position.
2. Ensure there is a 24VAC signal to the ENABLE. The ENABLE is a built-in on board fan relay.
3. Attach the leads of a DC voltmeter to the "METER" and "COM" terminals on the EPIC card. Read the DC volts.
4. Refer to the Fan Calibration Table inside the line voltage enclosure. Select the voltage that corresponds to the desired airflow (cfm or l/s) set point.
5. Adjust the potentiometers on the EPIC card to the desired voltage.

### Setting the Fan Airflow in the Dynamic Automation (0–10 VDC) Mode

1. Mode Selector Jumper must be in the "0–10V" position.
2. The ENABLE must be either be jumped to the 24 VAC supply (permanently enable) or provided with an isolated 24 VAC source from the terminal unit controller.
3. A 0–10 VDC input signal will determine the fan speed at the unit. Varying this signal will in turn vary the fan speed. At less than 0.26 VDC, the unit will turn off.

### Troubleshooting

1. Confirm the jumper on the EPIC card is in the correct position. The jumper should be in the "MAN" position for adjustment of fan speed at the unit. The jumper should be in the "0–10V" position for dynamic fan speed control via the controller.
2. If the motor does not run, turn off the power to the unit and verify that the power plug and the control plug are firmly and correctly attached to the motor. Then, turn the unit power back on and wait up to 20 seconds for the motor to start.
3. If the motor still does not start, turn off power and unplug both wiring harnesses from the motor.
4. Energize the unit. Check the AC voltage at the motor power plug. **IMPORTANT: Do not jam the voltmeter leads into the connectors. This will swage out the connectors and cause them to not make contact when the unit is plugged back in. Insert the probes into the plugs until they touch the pins. Do not penetrate the pins.** You should have full line voltage between the neutral and power lines, or between the two power lines in case of 240 VAC. If this is the case, go to step 5. If there is not a full line voltage signal at this point, check the voltage at the incoming power terminal block. If there is not a full line voltage signal at this point, turn off the power to the box and fix the problem with the electrician. If there is a full line voltage signal at the incoming terminal block, turn off the power to the box and reinstall the power cable harness
5. If there is a full voltage signal, and if the ground wire is properly connected, check the voltage at the EPIC card. Be sure that you have 24 - 28.5 VAC at the 24 VAC terminals. If you do not have voltage at this point, check the transformer.
6. If you have the correct input voltage, check between the common and the G terminal (Start/Stop). You should have approximately 24 VDC. If you do not have the proper voltage, replace the EPIC card.
7. If you have approximately 24 VDC between "COM" and "G", then check between "COM" and "PWM" (0-100% duty cycle). Depending on the input signal, it should be a modulating voltage between 0 and 24 VDC. Turn the potentiometer with the Mode Jumper in the "MAN" position to check this. If you do not have the proper voltage at this point, change the EPIC card.
8. If all the voltages check out, it is possible that the pins may not be connecting properly and it may be a good idea to recheck them at the plug near the motor. If there is no voltage between the G and common pins, check the ENABLE (on board fan relay) has 24 VAC. If there is a voltage discrepancy anywhere else, each source should be verified for proper voltage readings. Plug both cables back into the motor, turn on the power and wait for the motor to start.

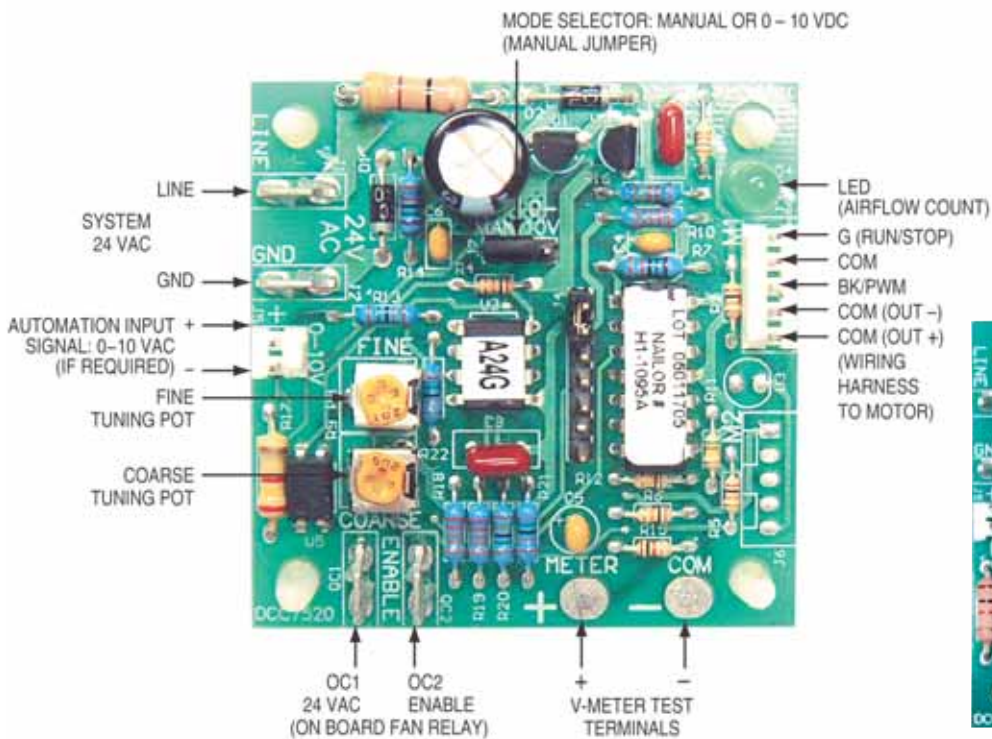

Figure 1. EPIC Single Motor Card.



Figure 2. EPIC Dual Motor Card.

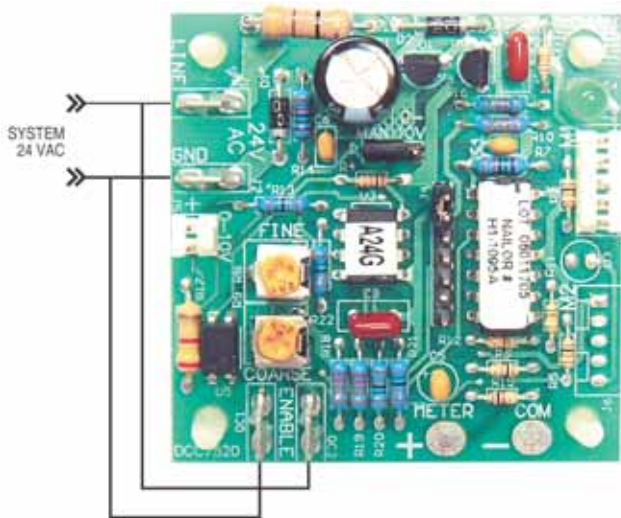

Figure 3. Without ENABLE (Permanently enabled).

Manual Mode: Fan runs all the time when terminal unit is energized (constant Volume).

Automation Mode: Variable Volume Fan Control capability with 0-10 VDC control signal input (Fan turns off at  $\leq 0.26$  VDC).

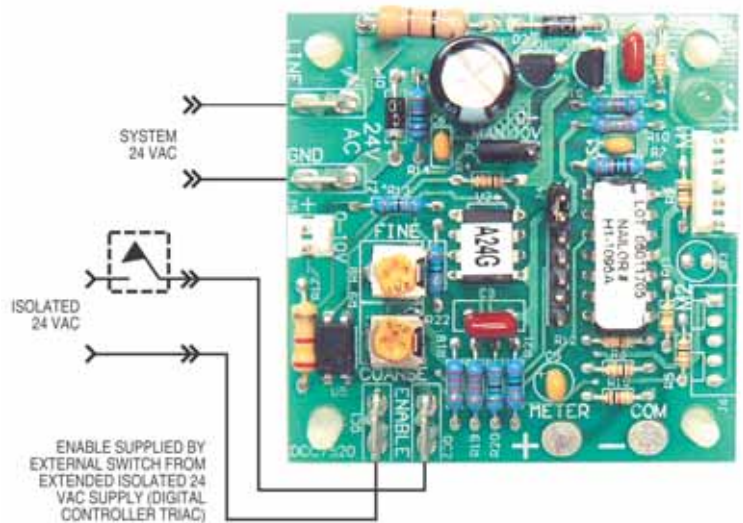

Figure 4. With ENABLE.

Manual Mode: Fan can be cycled on/off with 24 VAC signal from (constant Volume).

Automation Mode: Fan can be cycled on/off with 24 VAC signal from digital controller. In addition, a separate 0-10 VDC input provides variable volume fan control capacity (Fan turns off at  $\leq 0.26$  VDC).

Contractors check box to confirm steps 1-8 have been addressed. After addressing 1-8 please return to manufacturer for warranty action.

Inspectors Signature: \_\_\_\_\_



Houston, Texas  
Tel: 281-590-1172  
Fax: 281-590-3086

Las Vegas, Nevada  
Tel: 702-648-5400  
Fax: 702-638-0400

Toronto, Canada  
Tel: 416-744-3300  
Fax: 416-744-3360

Calgary, Canada  
Tel: 403-279-8619  
Fax: 403-279-5035