

**FOR USE IN AIR
HANDLING OPENINGS IN
CEILINGS FOR
PROTECTION AGAINST
FIRE AND HEAT RADIATION**

QUALIFICATIONS:

- UL 555C Classified Ceiling Damper. (File # 9660).
- CAN4-S112.2 Ceiling Firestop Flap Assemblies.
- California State Fire Marshal: Fire Damper Listing No. 3225-0935:102.
- City of New York Board of Standards and Appeals. Cal. No. 460-88-SA.
- Meets the requirements for NFPA 90A, IBC, BOCA, SBCCI, UBC, NBC (Canada) and associated local building codes.

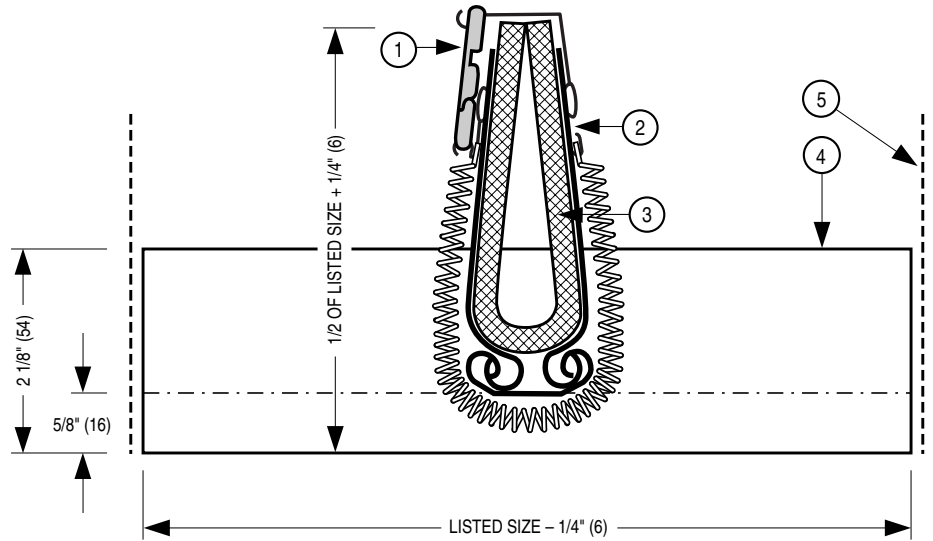

DESCRIPTION:

Ceiling dampers (known as Fire Stop Flaps in Canada) are designed to function as a fire and heat barrier in air handling openings penetrating fire resistive membrane ceilings. The 0700 Series is for use in lieu of hinged door type dampers in any UL/ULC floor/ceiling or roof/ceiling assembly with up to a 3 hour fire resistance rating where air handling openings are permitted.

CONSTRUCTION:

1. U.L. Listed fusible link, 212°F (100°C), standard.
2. Blades: 22 ga. (0.85) G60 galvanized steel.
3. Insulation: Non-asbestos UL Classified on units over 80 sq. in. (516 sq. cm) finished size, standard. Not required on smaller units.
4. Frame: Roll-formed 22 ga. (0.85) G60 galvanized steel.
5. Duct drop (by others).

NOTES:

1. Maximum size is 24" W x 24" H (610 x 610). Minimum size is 6" W x 3" H (150 x 75).
2. Units manufactured with blade length on long dimension (W) except where short dimension (H) is less than 6" (150). (See sketch 1).
3. If short dimension (H) is less than 6" (150), units are manufactured with blade length on short dimension. (See sketch 2).
4. For alternate unit with single blade, see dwg. 0700-1, Model 0714. For alternate unit with four blades, see dwg. 0700-4, Model 0716-4.
5. Installation Instructions: Refer to documents IOM-CRDSINST and CRDTBINST.

OPTIONS:

1. Non-standard temperature U.L. Listed fusible link.
 - 165°F (74°C)

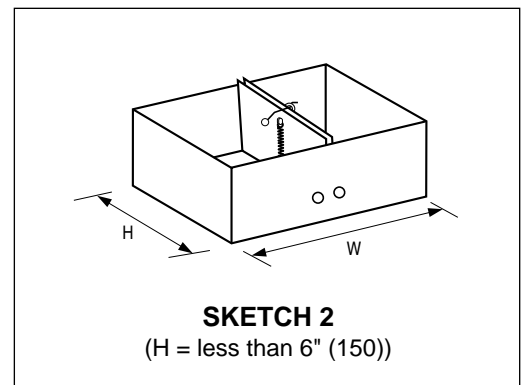
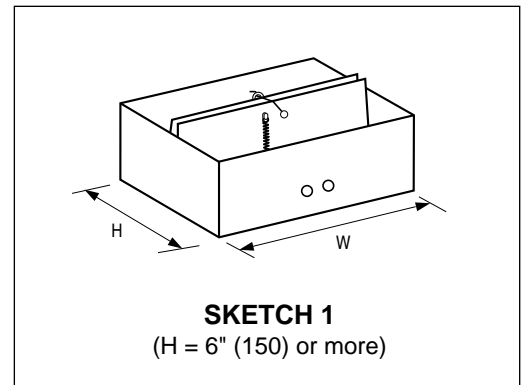

Dimensions are in inches (mm).

SCHEDULE TYPE:				
PROJECT:				
ENGINEER:				
CONTRACTOR:				
DATE	B SERIES	SUPERSEDES	DRAWING NO.	
11 - 1 - 04	0700	31 - 3 - 00R	0700-2	