



LOW LEAKAGE CONTROL DAMPER STEEL • STANDARD PERFORMANCE MODELS: 1010 & 1020 WITH FL FACE LINKAGE OPTION

The 1010/20 Series are Nailor's most widely used low leakage dampers and are the standard choice for use in the majority of low to medium velocity and pressure commercial HVAC systems. They are low cost, high quality dampers that meet or exceed the majority of standard specification requirements. They meet the frequently specified leakage criteria of less than 10 cfm per sq. ft at 4" w.g. (0.5% at 2000 fpm). The 1010FL/20FL design features include a sturdy hat channel frame with die-formed corner gussets for reinforcement and structural strength equivalent to 13 gauge channel type frames, a triple-vee blade design that maximizes strength and a robust heavy-duty face linkage design that offers easy accessibility and eliminates field adjustment problems.

STANDARD CONSTRUCTION:

- FRAME:** 5" x 7/8" x 16 ga. (127 x 22 x 1.6) galvanized steel hat channel with die-formed corner gussets. Low profile (flat top and bottom) on dampers 10" (254) high and under.
- BLADES:** 6" (152) wide on 5 1/2" (140) centers. 16 ga. (1.6) galvanized steel triple-vee design. Parallel or opposed action.
- LINKAGE:** Face type non-adjustable design in plated steel. Double sided on units 30" (762) wide and over.
- BEARINGS:** 1/2" (13) dia. Celcon®.
- AXLES:** 1/2" (13) dia. plated steel double bolted to blades.
- DRIVE SHAFT:** 6" (152) long x 1/2" (13) dia. lock-on drive shaft on all single section dampers. A 1/2" (13) or 1" (25) dia. factory installed jackshaft is standard on all multiple section dampers. See multi-section detail 1000 MSI.
- BLADE SEALS:** Dual durometer bulb type extruded PVC.
- JAMB SEALS:** Compression type cambered metal.
- MINIMUM SIZE:** Single blade (parallel): 6" x 4" (152 x 102).
Two blades (parallel or opposed): 6" x 10" (152 x 254).
- MAXIMUM SIZE:** Single section: 48" x 72" (1220 x 1829).
Multiple section assembly - unlimited.

TEMPERATURE RANGE: -50°F to 180°F (-45°C to 82°C)

OPTIONS:

- BO Oilite bearings
- AMP Actuator mounting side plate
- 304 Stainless Steel Construction
- Other _____.

Nailor offers a wide selection of pneumatic and electric actuators for factory or field installation.

PERFORMANCE DATA - AIR LEAKAGE (DAMPER CLOSED)

DAMPER WIDTH	MAXIMUM SYSTEM PRESSURE	MAXIMUM SYSTEM VELOCITY	LEAKAGE *	
			% OF MAX. FLOW	CFM/ SQ. FT.
48" (1219)	2.5" w.g.	2000 FPM	0.18	3.5
36" (914)	3.0" w.g.	2000 FPM	0.20	4.0
24" (610)	4.0" w.g.	2000 FPM	0.23	4.5
12" (305)	5.0" w.g.	2000 FPM	0.33	6.6

* Leakage information is based upon a pressure differential of 1" w.g. tested per AMCA Standard 500-D, Fig. 5.5.

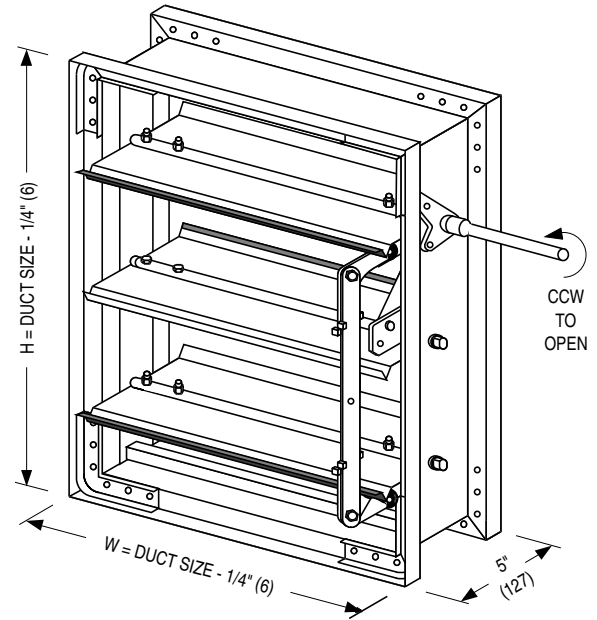

MODEL 1010FL
PARALLEL
BLADE

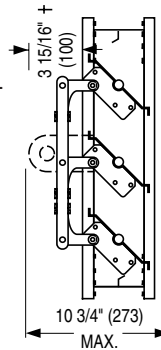

MODEL 1020FL
OPPOSED
BLADE

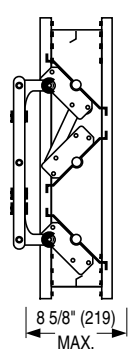

† jackshaft standard on multiple section dampers. Jackshaft securely bolted to frame.

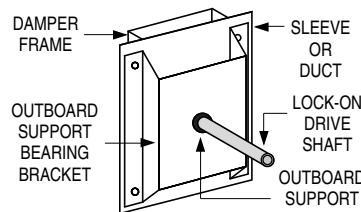

Lock-on drive shaft support bracket detail.

The low profile frame illustrated is used to maximize free area available on units 10" (254) high and under.

PRESSURE DROP (IN. W.G.)

DAMPER SIZE	APPROACH VELOCITY (FPM)			
	750	1000	1500	2000
24" x 24" (610 x 610)	.016	.030	.07	.14
36" x 36" (914 x 914)	.013	.023	.05	.09
48" x 48" (1219 x 1219)	.010	.020	.03	.07

Tested per AMCA Standard 500-D, Fig. 5.3.

Dimensions are in inches (mm).

SCHEDULE TYPE:				
PROJECT:				
ENGINEER:	DATE	C SERIES	SUPERSEDES	DRAWING NO.
CONTRACTOR:	6 - 30 - 04	1000	22 - 4 - 99RR	1000-1A