



# LOW LEAKAGE CONTROL DAMPER STEEL • STANDARD PERFORMANCE MODELS: 1010 & 1020 WITH 304 STAINLESS STEEL CONSTRUCTION OPTION

Nailor Models 1010/1020 with optional 304 Stainless Steel construction provide an enduring solution for corrosive environment commercial and industrial HVAC and process applications. The proven triple-vee blade design and sturdy hat channel frame with reinforcing corner gussets afford solid performance that will withstand many normally harsh atmospheric and process elements. The design also features stainless steel zero-maintenance concealed blade linkage for reduced pressure drop and turbulence, and stainless steel axles, bushings and hardware for long lasting operation suitable for use in applications with temperatures ranging from -50°F (-45°C) to 250°F (121°C) depending on blade configuration and leakage (seals) requirements.

### STANDARD CONSTRUCTION:

- FRAME:** 5" x 7/8" x 16 ga. (127 x 22 x 1.6) Type 304 stainless steel hat channel with stainless steel corner gussets. Frame and corner gussets are welded for rigidity. Low profile (flat top and bottom) on dampers 10" (254) high and under.
- BLADES:** 6" (152) wide on 5 1/2" (140) centers. 16 ga. (1.6) Type 304 stainless steel triple-vee design. Parallel or opposed action.
- LINKAGE:** Concealed type totally enclosed within the frame and out of the airstream. Type 304 stainless steel.
- BEARINGS:** 1/2" (13) dia. Type 304 stainless steel.
- AXLES:** 1/2" (13) dia. stainless steel double bolted to blades.
- DRIVE SHAFT:** 6" (152) long x 1/2" (13) dia. stainless steel rigid shaft on all single section dampers. A 1/2" (13) or 1" (25) dia. factory installed jackshaft is standard on all multiple section dampers. See multi-section detail 1000 MSI.
- BLADE SEALS:** Dual durometer bulb type extruded PVC.
- JAMB SEALS:** Compression type cambered stainless steel.
- MINIMUM SIZE:** Single blade (parallel): 6" x 4" (152 x 102).  
Two blades (parallel or opposed): 6" x 10" (152 x 254).
- MAXIMUM SIZE:** Single section: 48" x 72" (1220 x 1829).  
Multiple section assembly - unlimited.

**TEMPERATURE RANGE:** -50°F to +180°F (-45°C to +82°C).

### OPTIONS:

- AMP Actuator mounting side plate
- DLO Lock-on drive shaft
- Other \_\_\_\_\_.

Nailor offers a wide selection of pneumatic and electric actuators for factory or field installation.

### PERFORMANCE DATA - AIR LEAKAGE (DAMPER CLOSED)

DAMPER WIDTH	MAXIMUM SYSTEM PRESSURE	MAXIMUM SYSTEM VELOCITY	LEAKAGE *	
			% OF MAX. FLOW	CFM/SQ. FT.
48" (1219)	2.5" w.g.	2000 FPM	0.18	3.5
36" (914)	3.0" w.g.	2000 FPM	0.20	4.0
24" (610)	4.0" w.g.	2000 FPM	0.23	4.5
12" (305)	5.0" w.g.	2000 FPM	0.33	6.6

\* Leakage information is based upon a pressure differential of 1" w.g. tested per AMCA Standard 500-D, Fig. 5.5.

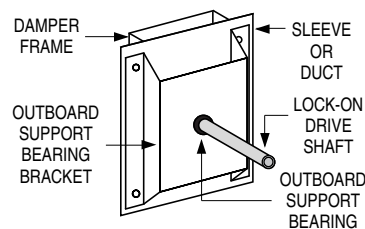
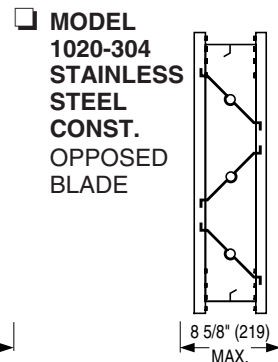
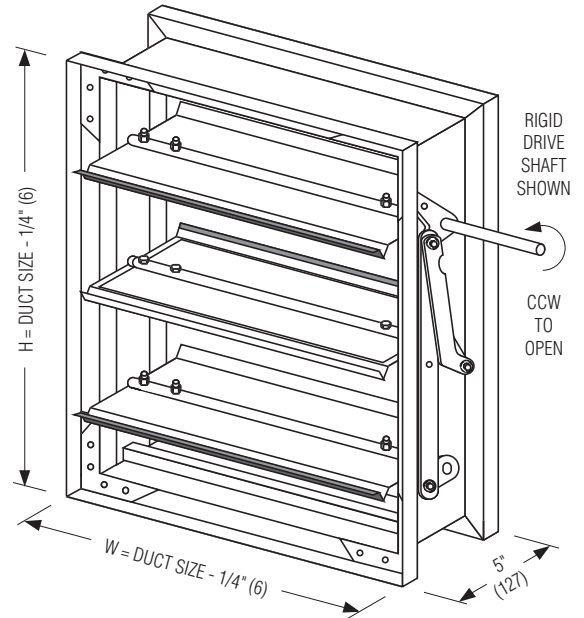

Optional lock-on drive shaft support bracket detail.

The low profile frame illustrated is used to maximize free area available on units 10" (254) high and under.

### PRESSURE DROP (IN. W.G.)

DAMPER SIZE	APPROACH VELOCITY (FPM)			
	750	1000	1500	2000
24" x 24" (610 x 610)	.016	.030	.07	.14
36" x 36" (914 x 914)	.013	.023	.05	.09
48" x 48" (1219 x 1219)	.010	.020	.03	.07

Tested per AMCA Standard 500-D, Fig. 5.3.

### SCHEDULE TYPE:

PROJECT:

ENGINEER:

CONTRACTOR:

Dimensions are in inches (mm).

DATE	A SERIES	SUPERSEDES	DRAWING NO.
6 - 30 - 04	1000	10 - 23 - 02	1000-1C