



LOW LEAKAGE CONTROL DAMPER STEEL • STANDARD PERFORMANCE MODELS: 1010 & 1020 WITH CR ROUND TRANSITIONS OPTION

The 1010CR/20CR Series are Nailor's most widely used low leakage multi-blade dampers in a low leakage casing with round transition collars and are the standard choice for use in the majority of commercial HVAC systems. They meet the frequently specified leakage criteria of less than 10 cfm per sq. ft at 4" w.g. (0.5% at 2000 fpm).

STANDARD CONSTRUCTION:

- FRAME:** 5" x 7/8" x 16 ga. (127 x 22 x 1.6) galvanized steel hat channel with die-formed corner gussets. Low profile (flat top and bottom) on dampers 10" (254) high and under.
- BLADES:** 6" (152) wide on 5 1/2" (140) centers. 16 ga. (1.6) galvanized steel triple-vee design. Parallel or opposed action.
- LINKAGE:** Concealed type totally enclosed within the frame and out of the airstream. Plated steel.
- BEARINGS:** 1/2" (13) dia. Celcon®.
- AXLES:** 1/2" (13) dia. plated steel double bolted to blades.
- DRIVE SHAFT:** 6" (152) long x 1/2" (13) dia. rigid drive shaft.
- BLADE SEALS:** Dual durometer bulb type extruded PVC.
- JAMB SEALS:** Compression type cambered metal.
- CASING:** Up to 36" x 36" (914 x 914) 20 ga. (1.0) galvanized steel.
36" x 36" (914 x 914) and up 18 ga. (1.31) galvanized steel.
Casing is tack-welded and caulked against leakage.

- MINIMUM SIZE:** Single blade: 4" (102) dia.
Two blades (parallel or opposed): 8" (203) dia.
- MAXIMUM SIZE:** Single section: 46" (1168) dia.

TEMPERATURE RANGE: -50°F to 180°F (-45°C to 82°C)

OPTIONS:

- BO Oilite bearings
- 304 Stainless Steel Construction
- Other _____

Nailor offers a wide selection of pneumatic and electric actuators for factory or field installation.

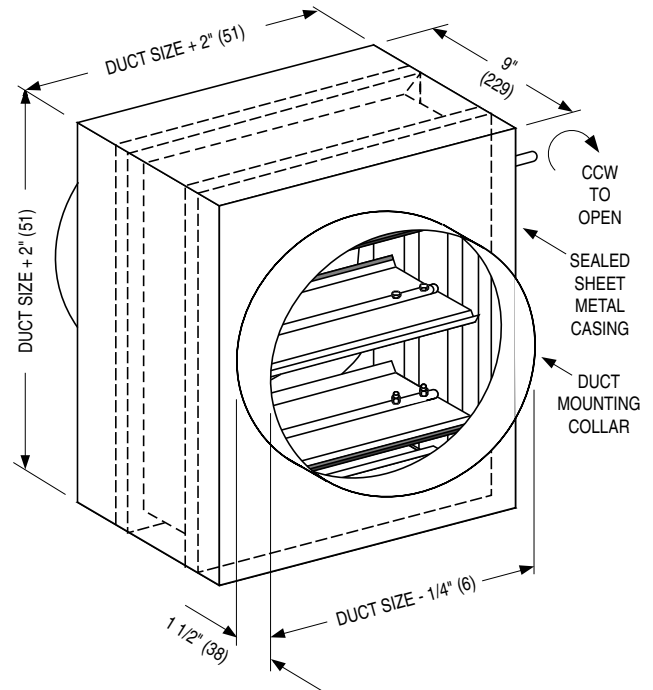

MODEL 1010CR
PARALLEL
BLADE

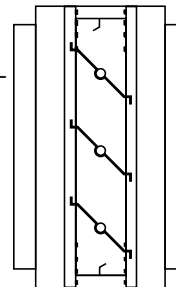

MODEL 1020CR
OPPOSED
BLADE

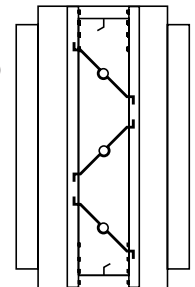

The low profile frame illustrated is used to maximize free area available on units 10" (254) high and under.

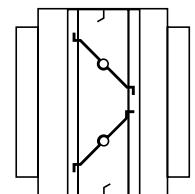

PERFORMANCE DATA - AIR LEAKAGE (DAMPER CLOSED)

DAMPER WIDTH	MAXIMUM SYSTEM PRESSURE	MAXIMUM SYSTEM VELOCITY	LEAKAGE *	
			% OF MAX. FLOW	CFM/SQ. FT.
48" (1219)	2.5" w.g.	2000 FPM	0.18	3.5
36" (914)	3.0" w.g.	2000 FPM	0.20	4.0
24" (610)	4.0" w.g.	2000 FPM	0.23	4.5
12" (305)	5.0" w.g.	2000 FPM	0.33	6.6

* Leakage information is based upon a pressure differential of 1" w.g. tested per AMCA Standard 500-D, Fig. 5.5.

PRESSURE DROP (IN. W.G.)

DAMPER SIZE	APPROACH VELOCITY (FPM)			
	750	1000	1500	2000
24" x 24" (610 x 610)	.016	.030	.07	.14
36" x 36" (914 x 914)	.013	.023	.05	.09
48" x 48" (1219 x 1219)	.010	.020	.03	.07

Tested per AMCA Standard 500-D, Fig. 5.3.

SCHEDULE TYPE:		Dimensions are in inches (mm).			
PROJECT:					
ENGINEER:	DATE	B SERIES	SUPERSEDES	DRAWING NO.	
CONTRACTOR:	6 - 30 - 04	1000	3 - 5 - 99RR	1000-3	