



COMBINATION FIRE/SMOKE DAMPER
AIRFOIL BLADE • HIGH PERFORMANCE
1 1/2 HR. LABEL • ULTRA-LOW LEAKAGE
MODEL: 1222
(TYPE B SLEEVE ENCLOSURE)



FOR DUCTS UNDER 8" (203) IN HEIGHT AND 8" (203) OR MORE IN WIDTH

QUALIFICATIONS:

- UL 555 & CAN/ULC-S112 CLASSIFIED DYNAMIC FIRE DAMPER 1 1/2 hr. Label (File # R9492).
- UL 555S CLASSIFIED SMOKE DAMPER (File # R9492) Leakage Class I or II at 250°F or 350°F elevated temperature.
- City of New York. MEA # 366-03-M.
- California State Fire Marshal: Fire Damper Listing No. 3225-0935:106.
- Meets NFPA 80, 90A, 92A, 92B, 101 and 105 as well as IBC and NBC (Canada) Building Code requirements.
- Maximum velocity: Up to 4000 fpm @ 8" w.g.

The 1220 Series dampers are ideal for applications where building codes require both a fire damper for the protection of ductwork penetrations in walls or floors that have a fire resistance rating of up to 2 hours and also require a leakage rated damper for operational smoke control in static or dynamic smoke management systems.

The 1220 Series has been especially designed and tested to provide premium performance and is AMCA licensed. It offers the lowest leakage class available and is qualified for installation with airflow in either direction and inverted mounting. Airfoil blade design and elimination of blade sills, top and bottom, provide a low pressure drop design.

Unique, inter-locking double skin blade design provides flame and smoke seal under fire conditions.

STANDARD SPECIFICATION:

Frame: 5" x 7/8" x 16 ga. (127 x 22 x 1.6) galvanized steel hat channel.

Blades: 14 ga. (2.0) equivalent galvanized steel formed airfoil on 5 1/2" (140) centers.

Linkage: Concealed in frame. 12 ga. (2.7) plated steel.

Bearings: 1/2" (13) dia. self-lubricating oilite bronze.

Axles: 1/2" (13) dia. plated steel double bolted to blades.

Jackshaft: 1/2" (13) dia. cadmium plated steel.

Jamb Seals: Stainless steel.

Heat Responsive Device (Controlled Closure):

ERL (Electric Resettable Link) is standard on dampers with electric actuators: 250°F (121°C) standard. 165°F (74°C), 212°F (100°C) and 350°F (176°C) available.

PRL (Pneumatic Replaceable Link) is standard on dampers with pneumatic actuators: 212°F (100°C) standard. 165°F (74°C) and 280°F (138°C) available.

Sizes (Duct W x H):

Velocity/ Pressure Rating	Elevated Temp. °F	Minimum		Maximum			
		Single Section		Single Section		Multiple Section	
		Vertical/Horizontal	Vertical	Horizontal	Vertical	Horizontal	
24, 34, 36, 46, 48	250/350	8" x 4" (203 x 102) Overall damper height is 8" (203); 6" (152) on duct sizes 18 x 5 1/2" (457 x 140) and under.		36" x 7 1/2" (914 x 191)	32" x 7 1/2" (813 x 191)	144" x 7 1/2" (3658 x 191)	128" x 7 1/2" (3251 x 191)

Note: Duct sizes less than 8" (203) in width require a Type 'C' enclosure (Model 1223).

SLEEVE/ENCLOSURE SELECTION:

- 1222** Standard factory sleeve (caulked to UL requirements) 16" long x 20 ga. (406 x 1.0) (18 ga. (1.3) for dampers over 84" (2134) in width). Available up to 36" (914) dependent upon wall thickness.
- 1222** Non-standard sleeve. Specify _____ length _____ ga. Available up to 36" (914) dependent upon wall thickness and 10 through 20 ga. (3.5 through 1.0).

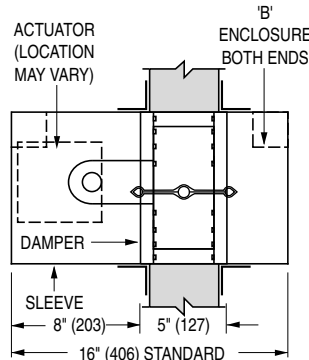
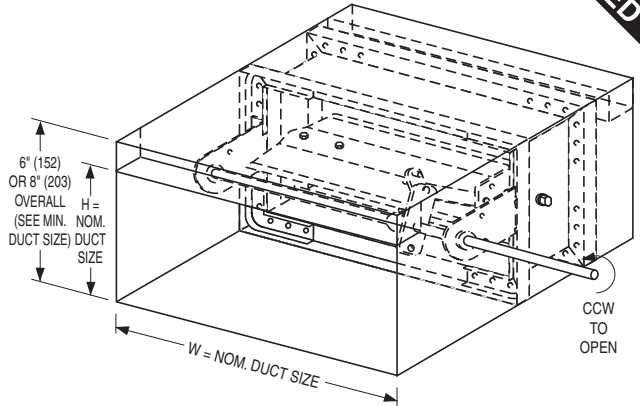

Wall Thickness	Minimum Sleeve Length
4 (102)	16 (406)
8 (203)	20 (508)
12 (305)	24 (610)
16 (406)	28 (711)

LEAKAGE CLASS / ELEVATED TEMPERATURE:

- I II @ 250°F (Standard)
- I II @ 350°F (Optional)

DYNAMIC VELOCITY/PRESSURE RATING:

- 24** 2000 fpm @ 4" w.g. (Standard)
- 34** 3000 fpm @ 4" w.g.
- 36** 3000 fpm @ 6" w.g.
- 46** 4000 fpm @ 6" w.g.
- 48** 4000 fpm @ 8" w.g. } (Optional)

ACTUATOR SELECTION:

- Electric Pneumatic

ACTUATOR LOCATION: External.

ACTUATOR FAIL POSITION: Closed.

OPTIONS:

- BS** Stainless steel bearings
- MLS-300** Position indicator switch pack
- MLS-400** Electric Fire Sensor (Re-openable control system). Includes dual heat sensors (165°F and 250°F or 350°F) and position indicator switch pack.
- QS1** Quick-set retaining angle (one side)
- QS2** Quick-set retaining angles (two sides)

SCHEDULE TYPE:

PROJECT:

ENGINEER:

CONTRACTOR:

For installation instructions, see IOM-1220INST.
 Dimensions are in inches (mm).

DATE	B SERIES	SUPERSEDES	DRAWING NO.
5 - 7 - 12	1200	5 - 9 - 11	1220-2