



HEAVY DUTY CONTROL DAMPERS

STEEL • VEE BLADES • FACE LINKAGE

MODELS: 1510 & 1520
1517 & 1527

The Nailor 1510-1527 Series is a heavy duty U-channel frame industrial damper with vee-groove style blades. Features include an adjustable face linkage design and stainless steel pivot pins which provide smooth control and easy maintenance. It is designed for "in-duct" mounting applications to control airflow and provide positive shut-off in HVAC or process air systems. Available with parallel or opposed blade operation. A variety of options make this damper extremely versatile and enable it to be tailored to the specific application.

RATINGS (see page 2 for specific limitations):

- Pressure: 2.9-20.1" w.g. (721-4997 Pa).
- Velocity: 3000-3500 fpm (15.2-17.8 m/s).
- Temperature: 250°F (121°C) standard. Dampers can be supplied for temperatures between 250°F (121°C) and 400°F (204°C) by increasing blade/frame clearance. Consult factory.

STANDARD CONSTRUCTION:

- FRAME:** 3" x 1" x 12 ga. (76 x 25 x 2.8) galvanized steel U-channel.
- BLADES:** 16 ga. (1.6) galvanized steel vee-blade, 8" (203) maximum width. Parallel or opposed blade action.
- LINKAGE:** Plated steel face linkage riveted to blade, in airstream.
- AXLES:** Models 1510/1520: 1/2" (13) dia. plated steel.
Models 1517/1527: 3/4" (19) dia. plated steel.
Axles are double bolted to blades.
- BEARINGS:** Self-lubricating sintered stainless steel sleeve type, pressed into frame.
- DRIVESHAFT:** 1/2" (13) or 3/4" (19) dia. (see Axles) plated steel. A 1" (25) dia. jackshaft is standard on multiple section dampers.
- FINISH:** Mill galvanized.
- MINIMUM SIZE:** Single blade parallel action: 5" x 5" (127 x 127).
Two blade either action: 8" x 14" (203 x 356).
- MAXIMUM SIZE:** Single section: 48" x 96" (1219 x 2438).
Multiple section assembly: Unlimited size.

OPTIONS:

- 304 Type 304 stainless steel construction (all parts within airstream, single section only)
- 316 Type 316 stainless steel construction (all parts within airstream, single section only)
- 14GF 5" x 7/8" x 14 ga. (127 x 22 x 2.0) hat channel frame (galvanized only)
- 14GB 2 x 14 ga. (2.0) blades (galvanized only)
- ASxx Type 304 stainless steel axles only
- BPV PVC blade seals (up to 180°F [83°C])
- BSE EPDM blade seals (up to 250°F [121°C])
- BSS Silicone blade seals (up to 400°F [204°C])
- JSS Stainless steel jamb seals
- LFS Type 304 stainless steel face linkage only

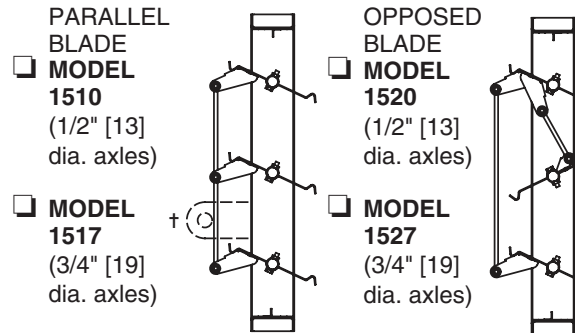
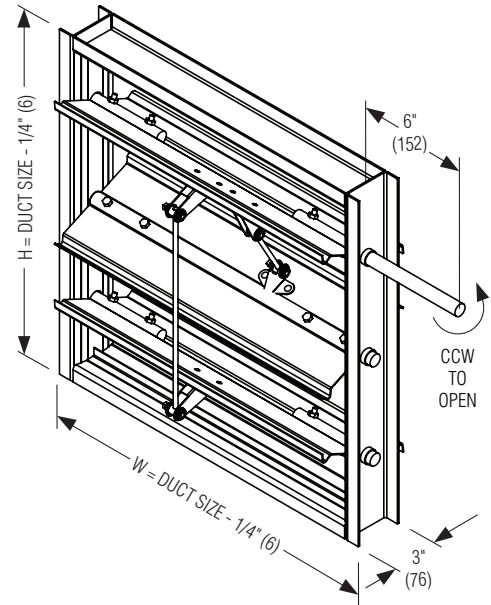

† jackshaft standard on multiple section dampers.

- HLQ Hand locking quadrant for 1/2" (13) dia. shaft
- HDLQ Heavy duty locking hand quadrant for 3/4" (19) dia. shaft or 1" (25) dia. jackshaft
- FMO Factory mounted actuator. Specify _____.
- Special Features. Specify: _____.

Note: For variations not shown, contact factory.

| | | | | | |
|-----------------------|-------------|--------------------------------|-------------------|--------------------|--|
| SCHEDULE TYPE: | | Page 1 of 2 | | | |
| PROJECT: | | Dimensions are in inches (mm). | | | |
| ENGINEER: | DATE | B SERIES | SUPERSEDES | DRAWING NO. | |
| CONTRACTOR: | 4 - 10 - 07 | 1500 | 3 - 28 - 07 | 1510 | |



HEAVY DUTY CONTROL DAMPERS
STEEL • VEE BLADES • FACE LINKAGE
MODELS: 1510 & 1520
1517 & 1527

PERFORMANCE LIMITATIONS:

| Damper Width | Models 1510/1520 | | Models 1517/1527 | |
|--------------|----------------------|----------------------|----------------------|----------------------|
| | Max. System Pressure | Max. System Velocity | Max. System Pressure | Max. System Velocity |
| 48" (1219) | 2.9 in. w.g. | 3000 fpm | 6.9 in. w.g. | 3500 fpm |
| 36" (914) | 3.7 in. w.g. | 3000 fpm | 11.0 in. w.g. | 3500 fpm |
| 24" (610) | 6.0 in. w.g. | 3000 fpm | 15.6 in. w.g. | 3500 fpm |
| 12" (305) | 8.3 in. w.g. | 3000 fpm | 20.1 in. w.g. | 3500 fpm |

Pressure and velocity limitations shown are guidelines for design purposes. Although ratings are on the conservative side, contact Nailor for requirements beyond limitations shown.

LEAKAGE:

| Damper Width | Models 1510/1520 | | | | Models 1517/1527 | | | |
|--------------|-------------------|----------------|--------------------|----------------|-------------------|----------------|--------------------|----------------|
| | Leakage w/o Seals | | Leakage with Seals | | Leakage w/o Seals | | Leakage with Seals | |
| | CFM per Sq. Ft. | % of Max. Flow | CFM per Sq. Ft. | % of Max. Flow | CFM per Sq. Ft. | % of Max. Flow | CFM per Sq. Ft. | % of Max. Flow |
| 48" (1219) | 31.5 | 1.05 | 4.2 | 0.14 | 31.5 | 0.90 | 4.2 | 0.12 |
| 36" (914) | 31.5 | 1.05 | 4.2 | 0.14 | 31.5 | 0.90 | 4.2 | 0.12 |
| 24" (610) | 39.0 | 1.30 | 8.5 | 0.28 | 39.0 | 1.12 | 8.5 | 0.24 |
| 12" (305) | 59.0 | 1.97 | 13.0 | 0.43 | 59.0 | 1.69 | 13.0 | 0.37 |

Leakage data is based upon a pressure differential of 1 in. w.g., tested in accordance with AMCA Standard 500-D, Figure 5.5.

PRESSURE DROP: SIZE: 36" x 36" (914 x 914)

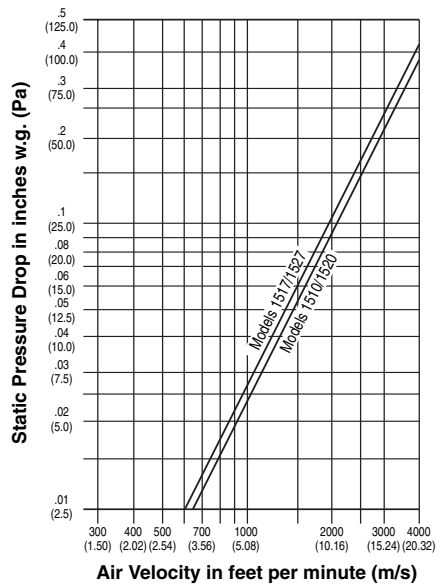

Tested per AMCA Standard 500-D using test set-up figure 5.3, ductwork upstream and downstream.

| | | | | |
|-----------------------|--------------------------------|-----------------|-------------------|--------------------|
| SCHEDULE TYPE: | Page 2 of 2 | | | |
| PROJECT: | Dimensions are in inches (mm). | | | |
| ENGINEER: | DATE | B SERIES | SUPERSEDES | DRAWING NO. |
| CONTRACTOR: | 4 - 10 - 07 | 1500 | 3 - 28 - 07 | 1510 |