

Model 1905CB is an extra heavy duty industrial counterbalanced backdraft damper designed to prevent the backflow of air while allowing for automatic air intake or exhaust in industrial HVAC or process air systems. Featuring an airfoil blade design, heavy duty blade linkage and ball bearings, Model 1905CB provides smooth, rattle-free operation at velocities of up to 4000 fpm. The counterweight is easily adjusted for desired opening pressure and the extra heavy duty flanged frame, with optional bolt holes, connects easily to flanged duct for fast, secure installation. Rugged steel construction and a wide selection of options make Model 1905CB a versatile performer for the most demanding applications.

STANDARD CONSTRUCTION:

FRAME: 8" x 2" x 10 ga. (203 x 51 x 3.5) coated steel channel.

BLADES: 7" (178) wide maximum, 2 x 18 ga. (1.3) galvanized steel, formed and welded into an airfoil cross-section.

LINKAGE: Heavy duty linkage arms and plated steel tie bar, concealed out of the airstream.

AXLES: 3/4" (19) dia. plated steel.

BEARINGS: Ball bearing type, pressed into frame.

COUNTERBALANCE: Adjustable, externally mounted.

MINIMUM SIZE: 6" x 6" (152 x 152).

MAXIMUM SIZE: 60" x 96" (1524 x 2438). For larger sizes, contact factory.

MAXIMUM

TEMPERATURE: 250°F (121°C) standard. 400°F (204°C) with HT option.

MAX. PRESSURE: 8 to 15 in. w.g. (see page 2).

MAX. VELOCITY: 4000 fpm (see page 2).

OPTIONS:

- BH Bolt holes in flanges
- CBI Internal counterbalance
- BSE EPDM blade seals (up to 250°F (121°C))
- BSS Silicone blade seals (up to 400°F (204°C))
- JSS Stainless steel jamb seals
- BESS Stainless steel sleeve bearings (pressed in)
- BEBR Relubricable ball bearings (bolt-on)
- 304 Stainless steel construction
- SSA 304 stainless steel axles only
- HT High temperature construction (up to 400°F (204°C))
- NSF Non-standard flange width (1 1/2" (38) to 4" (102))
Specify _____.
- Special _____.

Note: For variations not shown, contact factory.

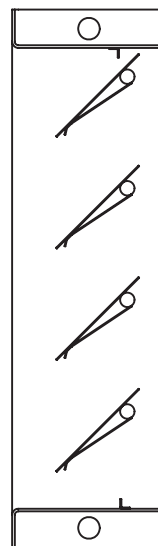
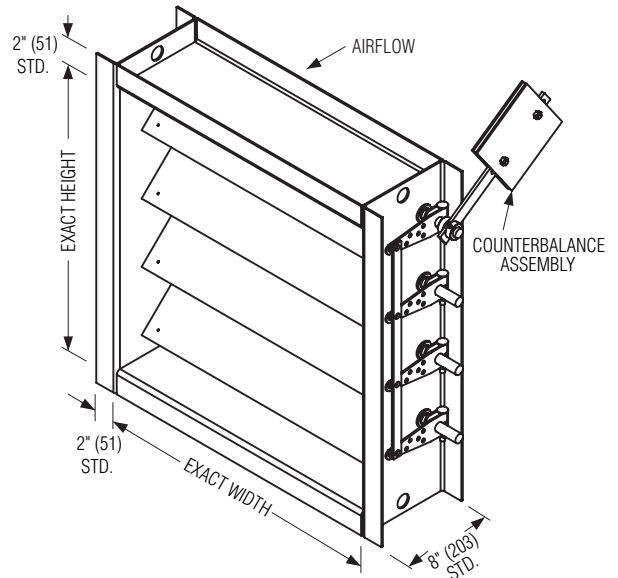
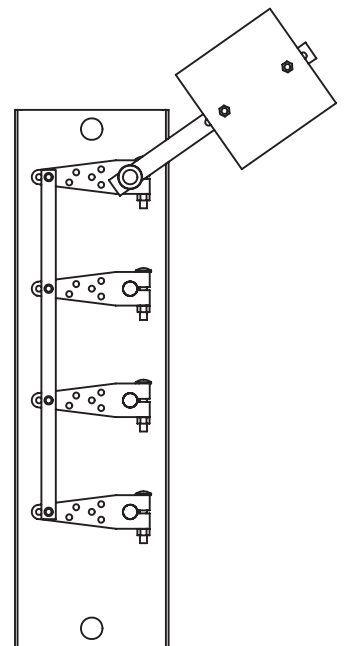
BLADES

LINKAGE
SCHEDULE TYPE:
PROJECT:
ENGINEER:
CONTRACTOR:

Page 1 of 2
 Dimensions are in inches (mm).

DATE
B SERIES
SUPERSEDES
DRAWING NO.

8 - 30 - 07

1900

3 - 30 - 06

1905CB



**HEAVY DUTY INDUSTRIAL BACKDRAFT DAMPER
COUNTERBALANCED • STEEL • AIRFOIL BLADE
PERFORMANCE DATA
MODEL: 1905CB**

PERFORMANCE LIMITATIONS:

Damper Width	Model 1905CB	
	Max. System Pressure	Max. System Velocity
60" (1524)	8.0 in. w.g.	4000 fpm
48" (1219)	9.0 in. w.g.	4000 fpm
36" (914)	10.0 in. w.g.	4000 fpm
24" (610)	12.0 in. w.g.	4000 fpm
12" (305)	15.0 in. w.g.	4000 fpm

Pressure and velocity limitations shown are guidelines for design purposes. Although ratings are on the conservative side, contact Nailor for requirements beyond limitations shown.

LEAKAGE:

Damper Width	Model 1905CB			
	Leakage w/o Seals		Leakage with Seals	
	CFM per Sq. Ft.	% of Max. Flow	CFM per Sq. Ft.	% of Max. Flow
60" (1524)	39.0	0.98	14.0	0.35
48" (1219)	39.0	0.98	14.0	0.35
36" (914)	49.0	1.25	15.0	0.38
24" (610)	60.0	1.50	17.0	0.43
12" (305)	99.0	2.48	20.0	0.50

Leakage data is based upon a pressure differential of 1 in. w.g., tested in accordance with AMCA Standard 500-D.

PRESSURE DROP: SIZE: 36" x 36" (914 x 914)

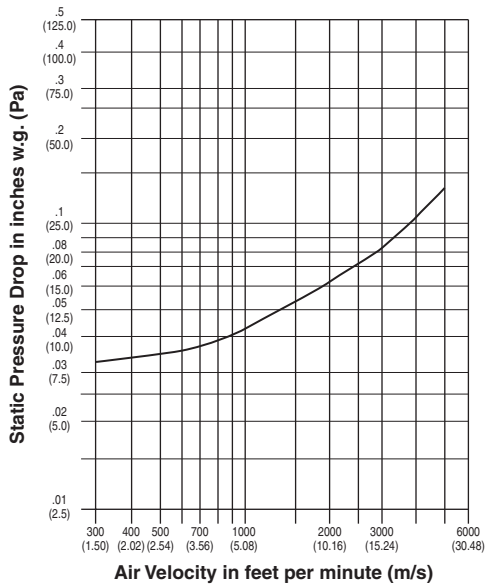

Tested per AMCA Standard 500-D using test set-up figure 5.3, ductwork upstream and downstream.

SCHEDULE TYPE:	Page 2 of 2			
PROJECT:	Dimensions are in inches (mm).			
ENGINEER:	DATE	B SERIES	SUPERSEDES	DRAWING NO.
CONTRACTOR:	8 - 30 - 07	1900	3 - 30 - 06	1905CB