

INSTALLATION:

Pneumatic Connection:

Connect the #1 air inlet port of the electric pneumatic (EP) switch mounted on the electric junction box to the pneumatic main air supply (1/8" (3) NPT barbed fitting). Metallic tubing requires a silicone tubing pigtail and compression fitting (by others). Rated operating main air pressure is 25 psi.

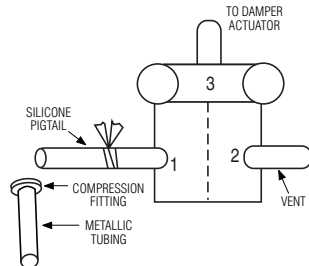

Electrical Connections for Pneumatic or Electrical Actuators

1. Remove cover of junction box. There are seven coded color wires. Consult applicable wiring diagram, see Figures 1, 2 and 3. Color coding of position indicator microswitches (Aux. switches) varies dependent upon actuator.

MS1 is damper open signal.

MS2 is damper closed signal.

Important: Installer must double check continuity of **MS1** and **MS2** before wiring to confirm which switch signals the damper's open or closed position.

2. Connect external wiring from the remote control panel and electrical power supply (120 or 24 Vac) in accordance with N.E.C. and any applicable local codes.
3. It is essential that the remote controls include a 3-position master control switch (single pole double throw, center off) and that it is connected to operate as shown.
4. Replace junction box cover and check operation.

OPERATION:

Circuit Test

Combination fire/smoke dampers with the MLS-400 Re-openable Fire Sensor option are supplied with factory mounted spring return actuators that have a power open/fail closed (normally closed) damper connection.

1. Place master control switch (MCS) in center closed position.
2. Apply power. The damper will remain closed and the closed (red) indicator light will go on.
3. Place MCS in reopen (override) position. The damper will open. The closed (red) indicator light will go off and the open (green) indicator light will go on. Note: When the MCS is in the reopen (override) position, the smoke detector (if used) and primary heat sensor are bypassed. The damper will remain open even if the primary heat sensor has been activated. Do not leave MCS in reopen position.
4. Place MCS in the normal (auto) position. The damper will remain open and the open (green) indicator light will remain on.

Emergency Operation (Smoke Control Management)

1. MCS Normal Position

(a) **Fire Control:** The damper is open and will remain so until the primary heat sensor activates when temperatures at the damper reach 165°F (74°C), when the damper will close. The primary heat sensor is a manual reset device and the damper will remain closed until the override signal for smoke management from a remote command station is present and the duct temperature has not exceeded the high limit. If temperatures reach the elevated temperature rating of the damper/actuator assembly (250°F or 350°F [121° or 177°C]), the high limit secondary heat sensor will close and lock damper, rendering it inoperable from a remote location. A manual reset button is provided on the MLS-400 that may be used to reopen damper upon cessation of fire conditions.

(b) **Smoke Control (Optional):** If a smoke detector (wired with normally closed contacts) is included in the design, when activated, power to the actuator is interrupted and the damper will close.

2. MCS Closed Position

The damper will close regardless of whether the primary heat sensor or smoke detector has activated or not.

3. MCS Reopen Position

If the damper has not been exposed to an elevated temperature higher than its rating (250 or 350°F [121 or 177°C]), the damper will open, bypassing the primary heat sensor and smoke detector regardless of whether they have been activated or not. This provides control of the smoke management system and is to be done only by an authorized party per NFPA 92A, Smoke Control Systems. If the damper has been exposed to an elevated temperature higher than its temperature degradation rating (250 or 350°F [121 or 177°C]), the damper will close and remain closed under all conditions (regardless of any MCS position) in accordance with NFPA 90A.

Testing

Damper system testing may be done by:

1. Remotely using the master control switch (MCS) to cycle the damper.
2. Activating the smoke detector.
3. Locally at the damper by heating the primary heat sensor by holding a match or lighter by its face. The primary heat sensor has a manual button for reset after it has cooled.

SCHEDULE TYPE				
PROJECT				
Page 1 of 2				
ENGINEER	DATE	B SERIES	SUPERSEDES	DRAWING NO.
CONTRACTOR	12 - 29 - 08	FD - ACC	7 - 19 - 07	MLS4INST-1

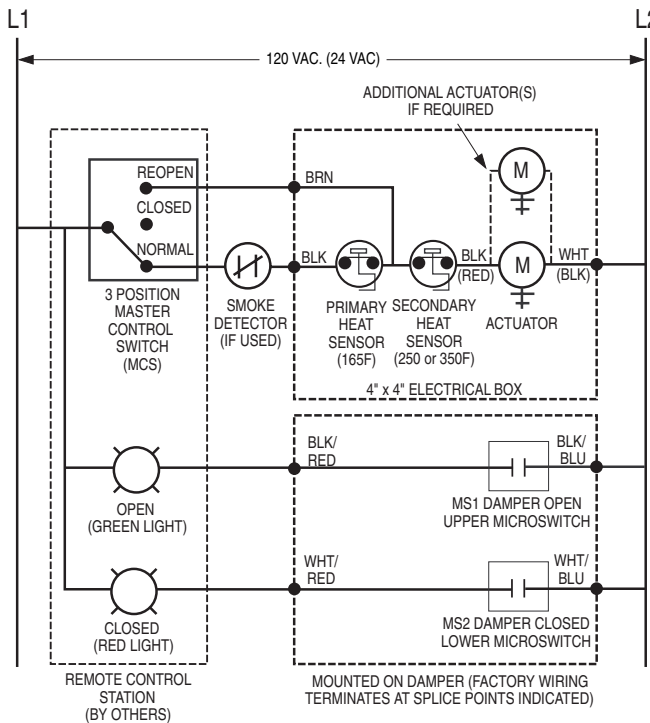

POSITION INDICATOR MICROSWITCH RATINGS: SINGLE POLE DOUBLE THROW (2). AT OR BELOW 240 VAC: RESISTIVE LOAD: 8A. INDUCTIVE LOAD: 2A. AT 125 VDC: 0.5A. PILOT DUTY: 4A, 125 VAC.

Fig. 1. MLS-400 with ML4X02/8X02, ML4115/8115 or MS4X09F/8X09F Electric Actuators and Honeywell rotary cam type position indicator package.

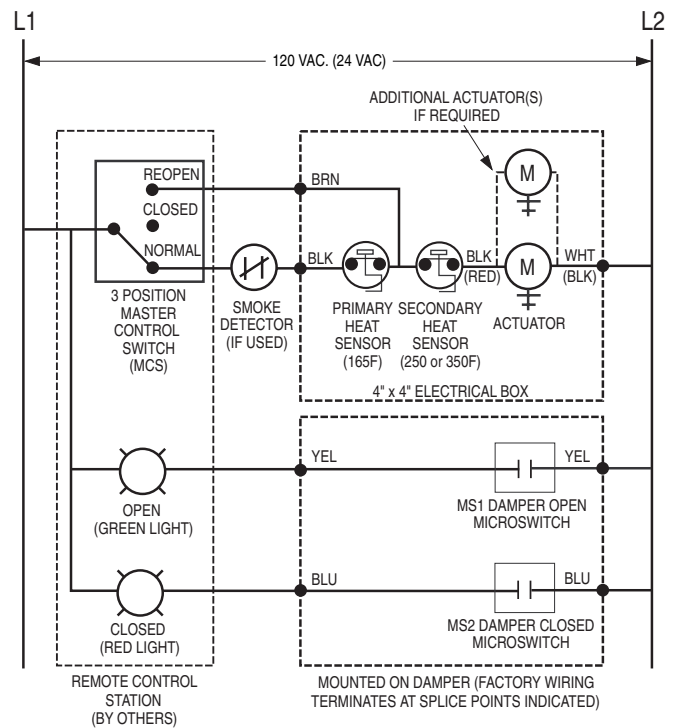

POSITION INDICATOR MICROSWITCH RATINGS: SINGLE POLE SINGLE THROW (2). MAX. LOAD: 250VAC, 5A RESISTIVE, 4A INDUCTIVE.

Fig. 2. MLS-400 with MS4120F/8120F Electric Actuators with built in Aux. switches.

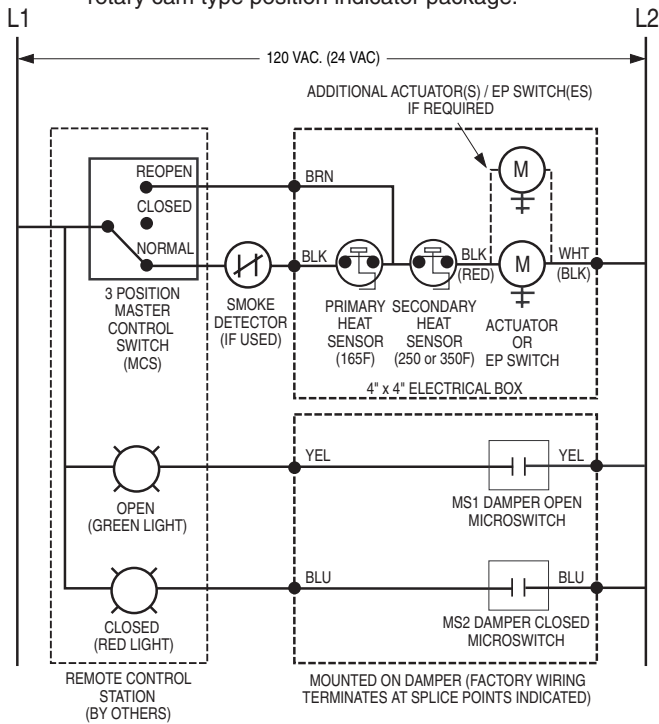

POSITION INDICATOR MICROSWITCH RATINGS: SINGLE POLE DOUBLE THROW (2). 15A, 125, 250 VAC OR 24 VDC. 0.5A, 125 Vdc, 0.25A, 250Vdc.

Fig. 3. MLS-400 with GGD221/121, MS4120F/8120F (electric) or 331-2961/3060 (pneumatic) actuators and Nailor position indicator package.

SCHEDULE TYPE

PROJECT

ENGINEER

CONTRACTOR

Page 2 of 2

DATE

B SERIES

SUPERSEDES

DRAWING NO.

12 - 29 - 08

FD - ACC

7 - 19 - 07

MLS4INST-1