



S20 Series Spring Return Direct Coupled Actuators

MS4120, MS7520, MS8120

SPECIFICATION DATA

MS4120, MS7520, MS8120 Spring Return Direct Coupled Actuators (DCA) are used within heating, ventilating, and air-conditioning (HVAC) systems. They can drive a variety of quarter-turn, final control elements requiring spring return fail-safe operation.

Applications include:

- Volume control dampers, mounted directly to the drive shaft or remotely (with the use of accessory hardware).
- Quarter-turn rotary valves, such as ball or butterfly valves mounted directly to the drive shaft.
- Linear stroke globe or cage valves mounted with linkages to provide linear actuation.

SPECIFICATIONS

Torque Ratings:

- Typical Holding, Driving, Spring Return: 175 lb-in. (20 N•m).
- Stall Maximum (fully open at 75°F): 350 lb-in. (39.6 N•m).

Electrical Ratings:

- See Table 1.

Electrical Connections:

- Field wiring 14 to 22 AWG (2.0 to 0.344 mm sq) to screw terminals, located under the removable access cover.

Stroke:

- 95° ±3°, mechanically limited.

Controller Type:

- See Models.
- Modulating (Series 70) or Floating (Series 60); controlled by selector switch.
- Input Impedance: 95K ohms minimum.
- Feedback Signal: 0 or 2-10 Vdc;
Driving current is 3 mA minimum.

Timing (At Rated Torque and Voltage):

- Drive Open (typical):
 - Floating, Modulating Models: 90 seconds.
 - Two-Position Models: 45 seconds ±5 seconds.
- Spring Close: 20 seconds typical.

Temperature Ratings:

- Ambient: -40°F to 140°F (-40°C to 60°C).
- Shipping and Storage: -40°F to 158°F (-40°C to 70°C).

Humidity Ratings:

- 5% to 95% RH noncondensing.

Design Life (at Rated Voltage):

- Two-position models: 50,000 full stroke cycles;
50,000 full stroke spring returns.
- Floating and Modulating models: 60,000 full stroke cycles;
1,500,000 repositions; 60,000 full stroke spring returns.

End Switches (Two SPDT):

- Settings (fixed): 7° nominal stroke, 85° nominal stroke.
- Ratings (maximum load):
 - Low-Voltage Models: 250 Vac, 5A resistive, 3A inductive.
 - Line-Voltage Models: 250 Vac, 5A resistive.

Dimensions:

- See Fig. 1.

FEATURES

- Brushless DC submotor with electronic stall protection for floating/modulating models.
- Brush DC submotor with electronic stall protection for 2-position models.
- Self-centering shaft adapter (shaft coupling) for wide range of shaft sizes.
- Models available for use with two-position, single pole single throw (spst), line- (Series 40) or low- (Series 80) voltage controls.
- Models available for use with floating or switched single-pole, double-throw (spdt) (Series 60) controls.
- Models available for use with proportional current or voltage (Series 70) controls.
- Models available with combined floating/modulating control in a single device.
- Models available with adjustable zero and span.
- Models available with line-voltage internal end switches.
- Access cover to facilitate connectivity.
- Metal housing with built-in mechanical end limits.
- Spring return direction field-selectable.
- Shaft position indicator and scale.
- Manual winding capability with locking function.
- UL (cUL) listed and CE compliant.
- All Models are plenum-rated per UL873.

Device Weight:

- 7 lb (3.2 kg).

Mounting:

- Self-centering shaft adapter (shaft coupling).
 - Round Damper Shafts: 0.375 to 1.06 in. (10 to 27 mm).
 - Square Damper Shafts: 1/2 to 3/4 in. (13 to 19 mm).
 - Actuator can be mounted with shaft in any position.

Minimum Damper Shaft Length:

- 1 in. (25 mm); 3 in. (76 mm) recommended.

Noise Rating at 1m (Maximum):

- Holding: 20 dBA (no audible noise).
- Two-position models:
 - Driving: 50 dBA.
 - Spring Return: 65 dBA.
- Floating and Modulating models:
 - Driving: 40 dBA.
 - Spring Return: 50 dBA.

Environmental Protection Ratings:

- NEMA2 (US Models) or IP54 (European Models) when mounted on horizontal shaft with access cover below shaft.

Approvals:

- UL/cUL.
- UL873 Plenum Rating, File No. E4436; Guide No. XAPX.
- CE.
- C-TICK.



Accessories:

- 27518 Balljoint (5/16 in.).
- 103598 Balljoint (1/4 in.).
- 205860 Electronic Minimum Position Potentiometer.
- 27520A-E,G,H-L,Q Pushrod (5/16 in. diameter).
- 32000085-001 Water-tight Cable Gland/Strain-relief Fitting (10 pack).
- 32003036-001 Weather Enclosure.
- 32004254-002 Self-Centering Shaft Adapter (supplied with actuator).
- 50001194-001 Foot Mount Kit.
- 50005859-001 NEMA4/4X Enclosure.
- 50006427-001 Anti-Rotation Bracket (supplied with actuator).
- SW2-US Auxiliary Switch Package.
- See also Form 62-2620.

Models:

S	Spring Return Fail Safe Mode	
20	175 lb-in. (20 N•m)	
	24-2POS	24 Vac Two-Position Control
	120-2POS	120 Vac Two-Position Control
	230-2POS	230 Vac Two-Position Control
	010	24 Vac Modulating and Floating Control
		Fixed Zero/Span, No End Switches
	-SW2	Internal End Switches
	-SER^a	Enhanced Modulating; Adjustable Zero/Span

S 20 24-2POS -SW2

^a Enhanced models include two internal end switches.

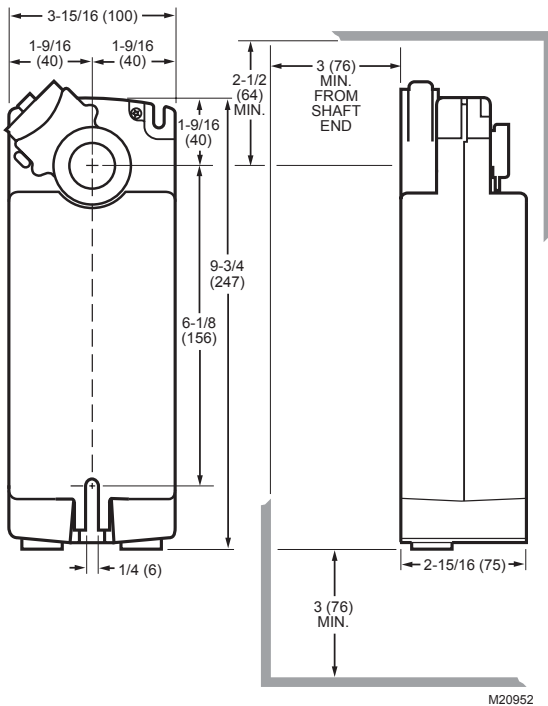

Fig. 1. Dimensional drawing of actuator in in. (mm).

TYPICAL SPECIFICATION

Spring return actuators shall be direct coupled type requiring neither crankarm nor linkage and be capable of direct mounting to a jackshaft of up to 1.05 in. diameter. The actuator shall connect to the shaft using a removable output hub with a self-centering shaft coupling. This coupling shall provide concentric mounting and include an integral adjustable range-stop mechanism.

The actuator shall provide two-position, floating, or proportional control. Proportional control refers to direct acceptance of 0-10 Vdc, 2-10 Vdc or—with addition of a 500 ohm resistor—a 4-20 mA input signal. Proportional and floating control models provide a 2-10 Vdc feedback signal. Actuators shall provide wiring terminals located within an integral access cover with conduit connections. Proportional and floating actuators shall have a rotation direction control switch accessible on the cover. Proportional and floating actuators shall use a brushless DC submotor. Two-position actuators shall use a brush DC submotor with a microprocessor control protected from overload at all angles of rotation.

All spring return actuators must be designed for either clockwise or counterclockwise fail-safe operation with a continuously engaged mechanical return spring. This spring must return the actuator to a fail-safe position within 20 seconds of power loss. All actuators shall provide a means of manually positioning the output hub in the absence of power. All actuators shall be designed for a minimum of 50,000 full-stroke cycles at actuator rated torque and temperature, 50,000 spring-return cycles and 1,500,000 repositions as documented in the product literature. Run time shall be constant and independent of: load, temperature, and supply voltage (within specifications). All actuators shall be UL873 and cUL (CSA22.2) listed, have a five year warranty, and be manufactured under ISO 9001 International Quality Control Standards. Actuators shall be as manufactured by Honeywell.

Table 1. Electrical Ratings.

Model(s)	Power Input		Power Consumption (VA)	
	Voltage	Frequency	Driving	Holding
Floating, Modulating	24 Vac ±20% (Class 2), 24 Vdc	50/60 Hz.	16	5
Two-Position, Low-voltage	24 Vac ±20% (Class 2), 24 Vdc	50/60 Hz.	40	8
Two-Position, Line-voltage	100-250 Vac	50/60 Hz.	60	13

Table 2. O.S. Number Selection

M	Electrical Motor	
S	Fail Safe Function (Spring Return)	
41	120 Vac Two-Position Control; Reversible Mount	
75	24 Vac Modulating and Floating Control; Reversible Mount	
81	24 Vac Two-Position Control; Reversible Mount	
20	175 lb-in. (20 N•m)	
	A	Standard U.S. Model
	B	Standard European Model
	E	Selectable control signal; Adjustable zero and span;
	H	Includes service and auto-adapt modes
	1	No Feedback
	2	Voltage Feedback Signal
	0	No End Switches
	2	Two End Switches
	XX	System Controlled Numbers

M S 75 20 A 2 0 XX

