

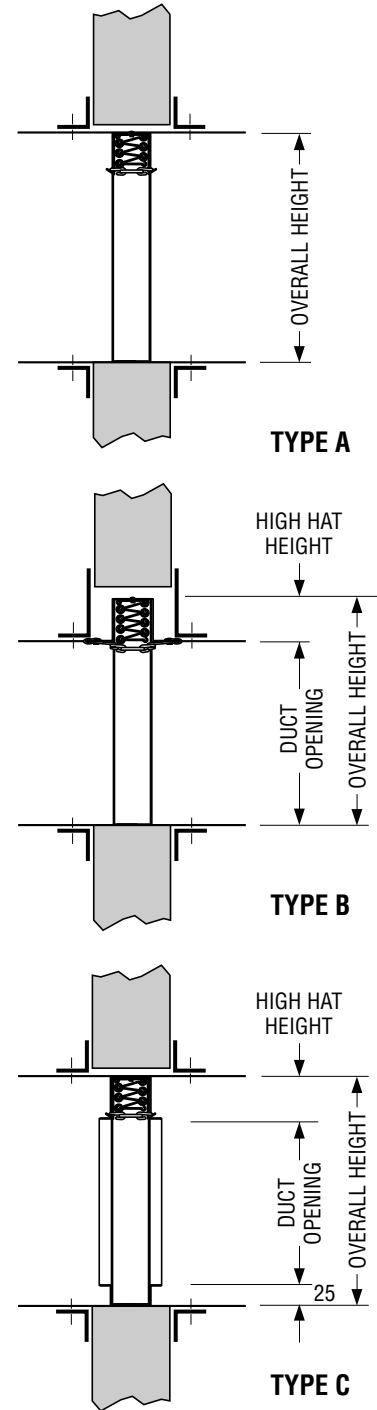

FIRE DAMPER SIZING CHART • METRIC
THINLINE FRAME (51 MM WIDE)
MODEL SERIES 0210 – 0240, 0570 – 0590

DUCT OPENING HEIGHT (mm)	TYPE "A" OVERALL HEIGHT (mm)	TYPE "B" OVERALL HEIGHT (mm)	TYPE "C" OVERALL HEIGHT (mm)
76		130	146
102	95	156	171
127	121	181	197
152	146	206	222
178	171	232	248
203	197	257	273
229	222	283	298
254	248	333	349
279	273	359	375
305	298	384	400
330	324	410	425
356	349	435	451
381	375	460	476
406	400	511	527
432	425	537	552
457	451	562	578
483	476	587	603
508	502	638	654
534	527	664	679
559	552	689	705
584	578	714	730
610	603	740	756
635	629	765	781
661	654	816	832
656	679	841	857
711	705	867	883
737	730	892	908
762	756	918	933
787	781	943	959
813	806	994	1010
838	832	1019	1035
864	857	1045	1060
889	883	1095	1111
914	908	1121	1137
940	933	1146	1162
965	959	1172	1187
991	984	1197	1213
1016	1010	1222	1238
1041	1035	1273	1289
1067	1060	1299	1314
1092	1086	1324	1340
1117	1111	1349	1365
1143	1137	1375	1391
1168	1162	1400	1416
1194	1187	1451	1467
1219	1213	1476	1492
1245	1238	1502	1518
1270	1264	1527	
1296	1289	DAMPER WIDTH OVERALL Type "A" = Duct Opening - 6. Type "B" = Duct Opening - 6. Type "C" = Duct Opening + 44.	
1321	1314		
1346	1340		
1372	1365		
1397	1391		
1423	1416		
1448	1441		
1473	1467		
1499	1492		
1524	1518		



Dimensions are in inches (mm).

SCHEDULE TYPE:
PROJECT:
ENGINEER:
CONTRACTOR:

DATE	B SERIES	SUPERSEDES	DRAWING NO.
11 - 10 - 00R	FD	NEW	SC4