

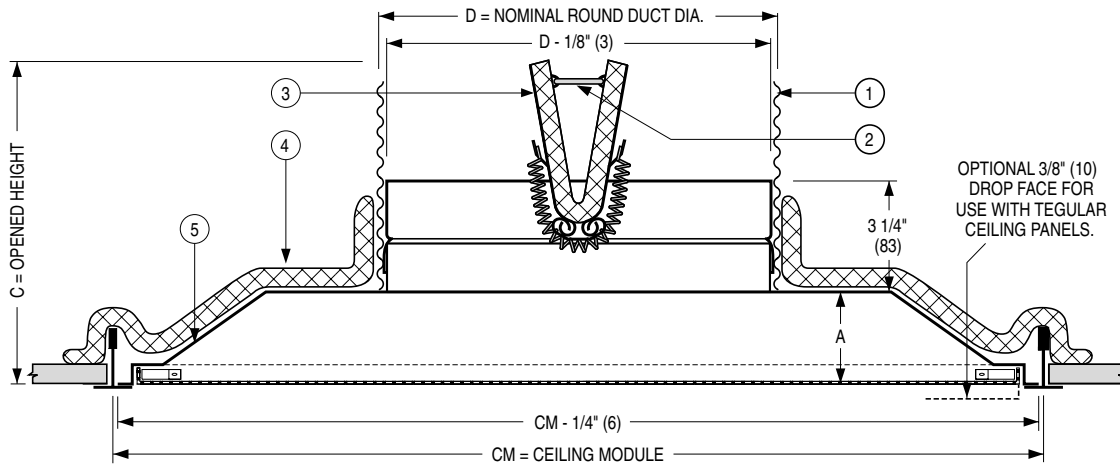

FIRE RATED CEILING DIFFUSER
RETURN • PERFORATED FACE •
STEEL • ROUND NECK
MODELS: 4070R, 4075R, 4080R AND 4085R



CATEGORY BZZU



CATEGORY 40U18.1-1/2A



	Imperial Modules						Metric Modules		
	Imperial Units (inches)			SI Units (mm)			SI Units (mm)		
Listed Neck Size	CM = 12 x 12			CM = 305 x 305			CM = 300 x 300		
	D	A	C	D	A	C	D	A	C
6	6	1 7/8	6 3/8	152	48	162	152	48	162
8	8		7 3/8	203		187	203		187
Listed Neck Size	CM = 24 x 24			CM = 610 x 610			CM = 600 x 600		
	D	A	C	D	A	C	D	A	C
6	6		6 7/8	152		175	152		175
8	8		7 7/8	203		200	203		200
10	10	2 3/8	8 7/8	254	60	225	254	60	225
12	12		9 7/8	305		251	305		251
14	14		10 7/8	356		276	356		276

- MODEL 4070R FLUSH FACE**
- MODEL 4075R DROP FACE**
12 x 12 (300 x 300) module
Type L Lay-in Frame
- MODEL 4080R FLUSH FACE**
- MODEL 4085R DROP FACE**
24 x 24 (600 x 600) module
Type L Lay-in Frame

ITEMS:

- Flexible air duct (UL/ULC Class 0 or 1) connector or steel duct.
- U.L. Listed fusible link. 212°F (100°C) standard.
- Ceiling radiation damper/fire stop flap.
- Ceramic fibre thermal blanket.
- Corrosion resistant steel diffuser.

- The perforated face has 3/16" (5) dia. holes on 1/4" (6) staggered centres.
- Standard finish is AW Appliance white.

DESCRIPTION:

- All models are classified for use in UL/ULC restrained or unrestrained floor/ceiling and or roof/ceiling assemblies which incorporate an exposed grid suspended ceiling (lay-in T-bar) with up to a 3 hour rating. For details of fire rated assemblies, see the current UL Fire Resistance Directory or ULC List of Equipment and Materials Vol. III Fire Resistant Ratings.
- The diffuser has concealed latches for easy access to the damper through the removable face.
- Designed as a matching return to compliment supply units. Perforated face has 3/16" (5) dia. holes on 1/4" (6) staggered centers.

OPTIONS:

- AV Fusible link adjustable volume control (Model 0722A damper).
 - Non-standard temperature U.L. Listed fusible link.
 165°F (74°C) 286°F (141°C)
 - Finish:
 SP Special
 BA Black back pan with an appliance white face.
 BW Black back pan with an off-white face.
- For installation instructions, see drwgs. 4000-1A and 1B or 4000-2A and 2B.**

Dimensions are in inches (mm).

SCHEDULE TYPE:				
PROJECT:				
ENGINEER:	DATE	B SERIES	SUPERSEDES	DRAWING NO.
CONTRACTOR:	19 - 4 - 99RR	4000	4 - 28 - 97	4000-6C