



**FIRE RATED DUCTLESS
RETURN AIR FILTER GRILLES
WITH ADJUSTABLE VOLUME CONTROL
MODELS: 4121 AV THRU 4126 AV**

**Louvered Grille
Models • With
AV Option:**

4121 AV, 4122 AV,
4123 AV

**Eggcrate Grille
Models • With
AV Option:**

4124 AV, 4125 AV,
4126 AV

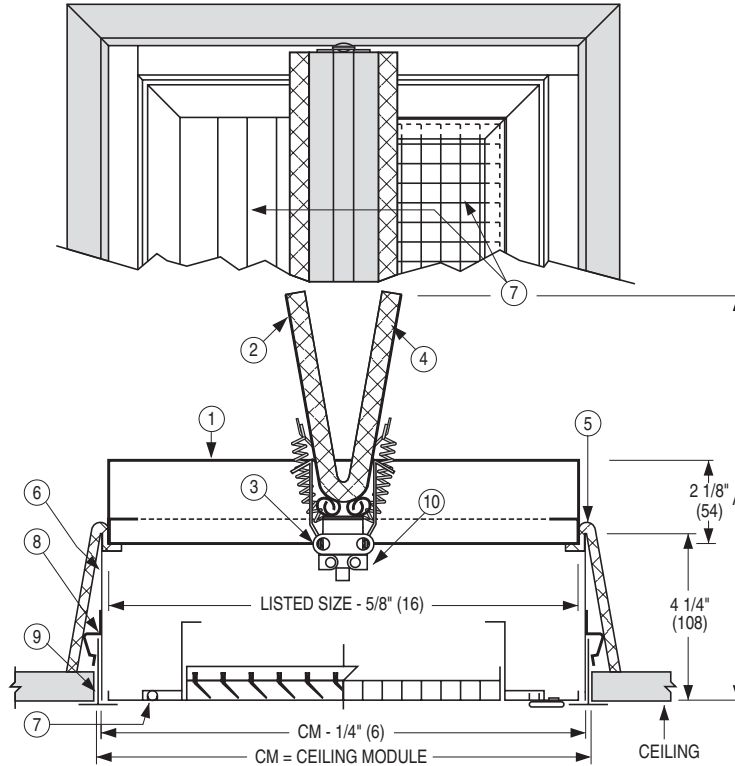

CATEGORY
BZZU & CABS



CATEGORY
40U18.2W

DESCRIPTION:

1. Damper frame: galvanized steel, standard.
2. Damper blades: galvanized steel, standard.
3. U.L. Listed fusible link: 212°F (100°C) standard.
4. Blade insulation: ceramic fiber.
5. Shroud: ceramic fiber.
6. Extension frame: galvanized steel, standard.
7. Steel filter grille with hinged core secured by 1/4 turn fasteners. 1" (25) filter by others.
Louvered face: fixed 45° deflection blades on 3/4" (19) centers.
Eggcrate face: 1/2 x 1/2 x 1/2 (13 x 13 x 13) aluminum grid core.
Standard finish: AW Appliance white baked enamel.
8. Ceiling grid clip: 4 attached. 2 each on opposite sides.
9. Supplementary (or existing) ceiling grid member.
10. AV Adjustable fusible link assembly permits the damper to be used as a balancing damper for volume control. The blades are adjusted with a 3/16" (5) hex key (by others) and perform like a butterfly damper.

OPTIONS:

1. Non-standard temperature U.L. Listed fusible link.
 165°F (74°C) 286°F (141°C)
2. Finish:
 SP Special _____.

The **Nailor Series 4100** are UL/ULC classified fire rated ceiling diffuser assemblies listed in Underwriters Laboratories Fire Resistance Directory and Underwriters' Laboratories of Canada List of Equipment and Materials. This design meets UL time-vs-temperature test criteria and NFPA 90A requirements.

All diffusers are classified for use in UL/ULC restrained or unrestrained floor/ceiling and/or roof/ceiling assemblies which incorporate an exposed grid suspended ceiling (lay-in T-bar) with up to a 3 hour rating. For details of fire rated assemblies, see the current UL Fire Resistance Directory or ULC List of Equipment and Materials Vol. III Fire Resistant Ratings.

For use with exposed grid T-bar ceilings only.

For installation instructions see dwg. 4100-4.

Available Sizes and Dimensional Data

Model No.	Filter Grille	Ceiling Module		Opening Height A
		Imperial (inches)	Metric (mm)	
4121 AV	Louvered Face	12 x 12	300 x 300	10" (254)
4122 AV		24 x 12	600 x 300	10" (254)
4123 AV		24 x 24	600 x 600	16" (406)
4124 AV	Eggcrate Face	12 x 12	300 x 300	10" (254)
4125 AV		24 x 12	600 x 300	10" (254)
4126 AV		24 x 24	600 x 600	16" (406)

SCHEDULE TYPE:

PROJECT:

ENGINEER:

CONTRACTOR:

Dimensions are in inches (mm).

DATE

B SERIES

SUPERSEDES

DRAWING NO.

7 - 9 - 01

4100

4 - 28 - 97

4100-2B