

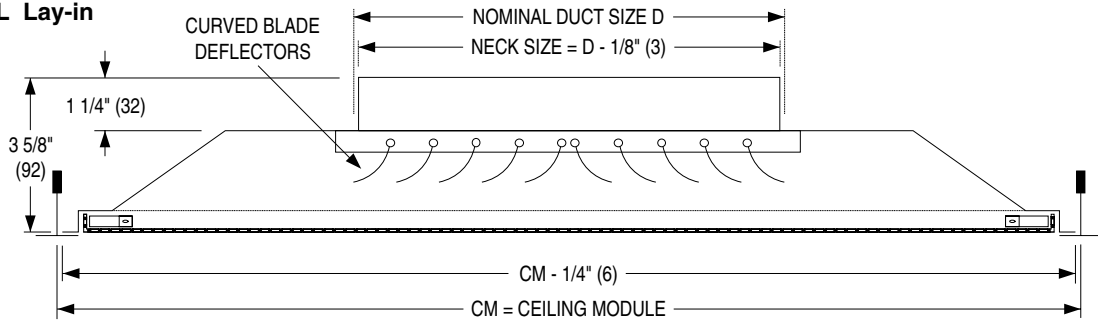

PERFORATED CEILING DIFFUSERS
CURVED BLADE • SUPPLY • FLUSH FACE
4-WAY ADJUSTABLE DISCHARGE PATTERN
MODELS: 4320CB, 4320CBA, 4320CBAA

TYPE L Lay-in



Available Combinations of Ceiling Module vs. Neck Size

Ceiling Module CM		Nominal Duct Size D			
Imperial Modules	Metric Modules	Round Neck		Square Neck	
		Imperial Units (in.)	Metric Units (mm)	Imperial Units (in.)	Metric Units (mm)
12 x 12	300 x 300	6, 8	152, 203	6 x 6, 8 x 8,	152 x 152, 203 x 203
16 x 16	400 x 400	6, 8, 10, 12	152, 203, 254, 305	6 x 6, 8 x 8, 10 x 10, 12 x 12	152 x 152, 203 x 203, 254 x 254, 305 x 305
24 x 12	600 x 300	6, 8	152, 203	6 x 6, 8 x 8,	152 x 152, 203 x 203
20 x 20	500 x 500	6, 8, 10, 12, 14	152, 203, 254, 305, 356	6 x 6, 8 x 8, 10 x 10, 12 x 12	152 x 152, 203 x 203, 254 x 254, 305 x 305
24 x 24	600 x 600	6, 8,	152, 203,	6 x 6, 8 x 8,	152 x 152, 203 x 203,
		10, 12,	254, 305,	10 x 10, 12 x 12,	254 x 254, 305 x 305,
		14, 15,	356, 381,	14 x 14, 15 x 15,	356 x 356, 381 x 381,
		16, 18	406, 457	16 x 16, 18 x 18	406 x 406, 457 x 457

DESCRIPTION:

1. Material: Corrosion-resistant steel.
2. Discharge pattern adjustable from horizontal to vertical.
Blades are individually adjustable. Standard diffuser has a 4-way (B4) discharge pattern.
3. Removable face has concealed latches for easy access to core and optional damper.
4. Perforated face has 3/16" diameter holes on 1/4" staggered centres.
5. Excellent performance in VAV systems.
6. Standard finish is AW Appliance White.

OPTIONS:

- Aluminum perforated face/steel backpan. (Model 4320CBA).
 - Aluminum perforated face and backpan. (Model 4320CBAA).
 - EX External Foil-Back Insulation, installed - R-4.2
 - EXB External Foil-Back Insulation, ships loose - R-4.2
 - MIB Molded Insulation Blanket - R-6.0 (24 x 24 only)
- Finish:
- BA Black back pan and deflectors with Appliance White face.
 - SP Special _____.
- Blow Pattern:
- B3 3-way
 - B2 2-way opposite
 - C2 2-way corner
 - B1 1-way

Fineline® is a registered trademark of USG Interiors Inc.

TYPE S Surface Mount

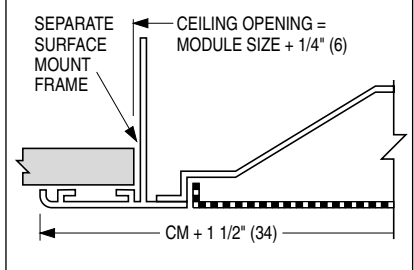

TYPE F Fineline® T-Bar

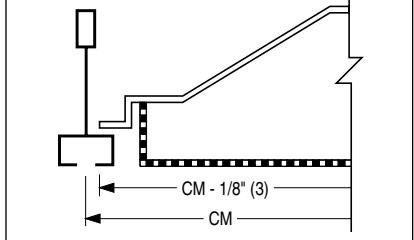

TYPE SP Spline

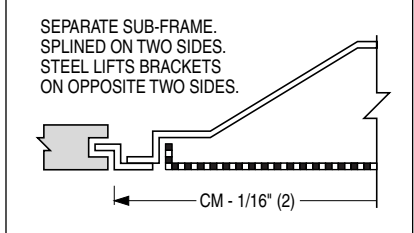

TYPE M Metal Pan (Snap-in)

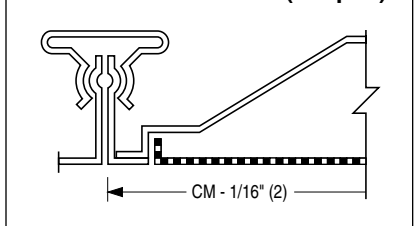

Dimensions are in inches (mm).

SCHEDULE TYPE:

PROJECT:

ENGINEER:

CONTRACTOR:

DATE

B SERIES

SUPERSEDES

DRAWING NO.

11 - 2 - 07

4300

10 - 26 - 01R

4320CB