

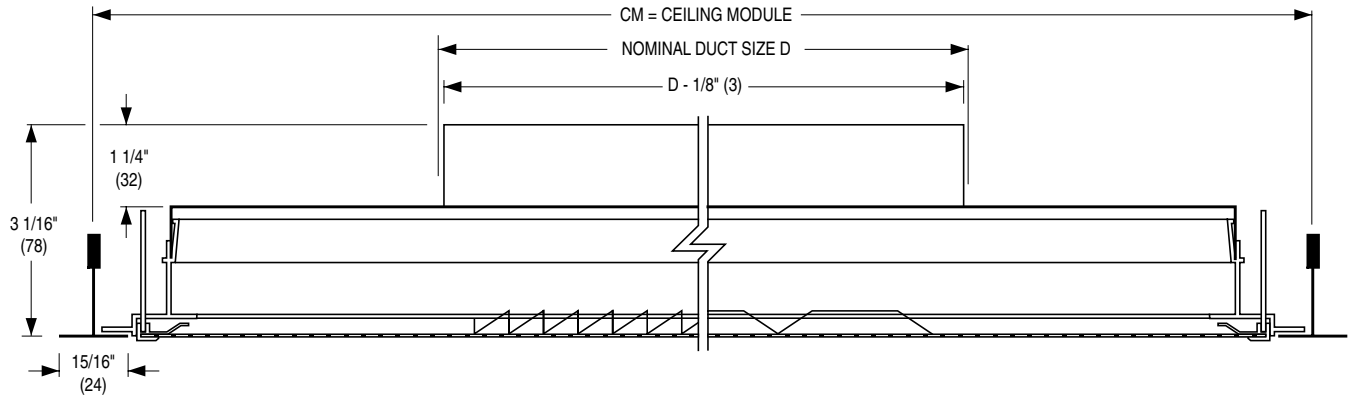

**PERFORATED CEILING DIFFUSER**  
 SUPPLY • PREMIUM ARCHITECTURAL QUALITY  
 ADJUSTABLE DISCHARGE PATTERN  
**MODELS: 4330, 4330A**

**TYPE L Lay-in T-Bar**



**Available Combinations of Ceiling Module vs. Neck Size**

Ceiling Module CM		Nominal Duct Size D			
Imperial Modules	Metric Modules	Round Neck		Square Neck	
		Imperial Units (in.)	Metric Units (mm)	Imperial Units (in.)	Metric Units (mm)
12 x 12	300 x 300	5, 6, 7, 8	127, 152, 178, 203	6 x 6, 8 x 8	152 x 152, 203 x 203
24 x 12	600 x 300	5, 6, 7, 8	127, 152, 178, 203	6 x 6, 8 x 8, 18 x 6	152 x 152, 203 x 203, 457 x 152
16 x 16	400 x 400	5, 6, 7, 8, 10	127, 152, 178, 203, 254	6 x 6, 8 x 8	152 x 152, 203 x 203
20 x 20	500 x 500	5, 6, 7, 8, 10, 12, 14	127, 152, 178, 203, 254, 305, 356	6 x 6, 8 x 8, 10 x 10	152 x 152, 203 x 203, 254 x 254
24 x 24	600 x 600	6, 8, 10, 12, 14, 15, 16	152, 203, 254, 305, 356, 381, 406	6 x 6, 8 x 8, 10 x 10, 12 x 12, 14 x 14	152 x 152, 203 x 203, 254 x 254, 305 x 305, 356 x 356

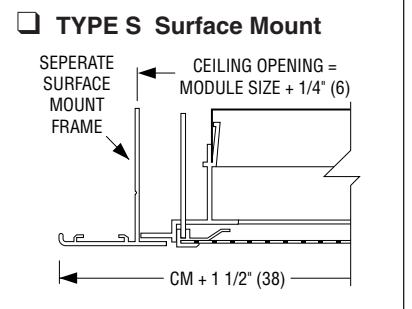

**DESCRIPTION:**

1. Material: Extruded aluminum border frame. Corrosion-resistant steel perforated face and back pan.
2. Designed for architectural appeal, the diffuser features a mitered corner aluminum frame that encapsulates the perforated face providing a narrow, visible border within the T-bar module. Discharge pattern can be adjusted to a 1, 2, 3 or 4-way pattern setting. Discharge pattern is adjusted by dropping the perforated face and rotating the pattern deflectors. Factory supplied in a 4-way setting.
3. Removable face has quick release spring latches for easy access to optional damper.
4. Perforated face has 3/16" (5) diameter holes on 1/4" (6) staggered centers.

5. Excellent performance in VAV systems.
6. Standard finish is AW Appliance White.

**OPTIONS:**

- Aluminum perforated face/steel backpan. (Model 4330A).
- Finish:
  - BA Black back pan and deflectors with Appliance White face.
  - SP Special \_\_\_\_\_.

**SCHEDULE TYPE:**

**PROJECT:**

**ENGINEER:**

**CONTRACTOR:**

Dimensions are in inches (mm).

DATE	B SERIES	SUPERSEDES	DRAWING NO.
10 - 5 - 99RR	4300	8 - 25 - 98	4330-1