

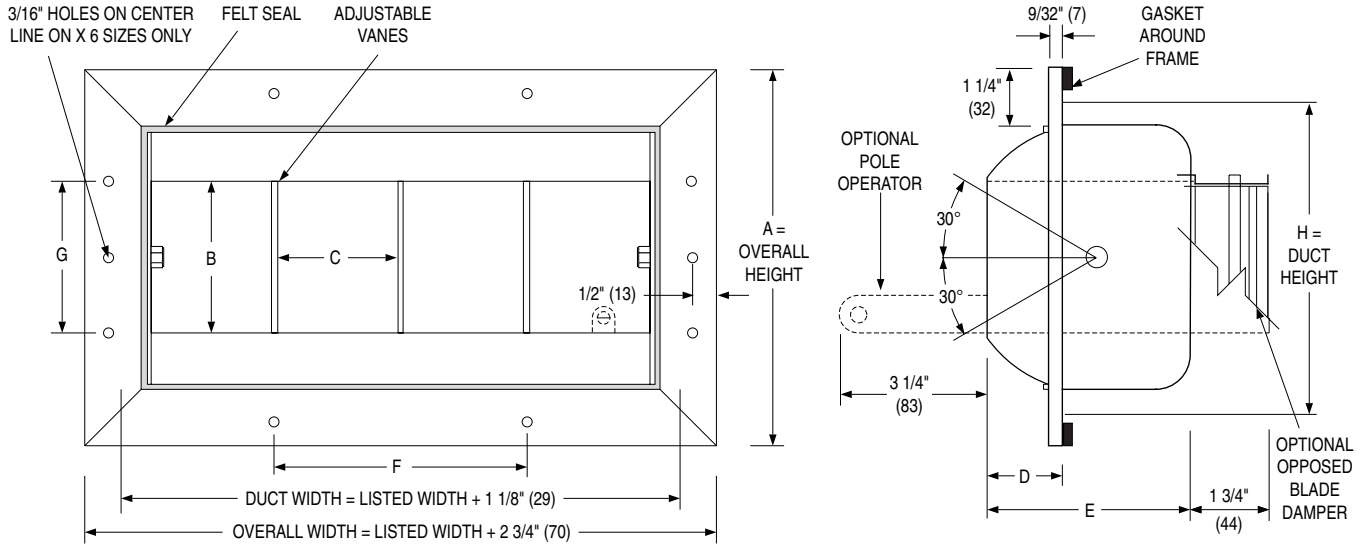

**INDUSTRIAL SUPPLY GRILLES**  
**DRUM LOUVER • ALUMINUM • HIGH CAPACITY**  
**MODEL: 45DL1**  
**(ADD -0 FOR OPTIONAL OBD)**



**AVAILABLE SIZES AND DIMENSIONAL DATA**

HEIGHT	6		10		12		15	
	W x H	NO. OF VANES	W x H	NO. OF VANES	W x H	NO. OF VANES	W x H	NO. OF VANES
LISTED SIZES NOMINAL WIDTH x HEIGHT IN INCHES	9 x 6	2	18 x 10	2	18 x 12	2	18 x 15	2
	12 x 6	3	24 x 10	3	24 x 12	3	24 x 15	3
	15 x 6	4	30 x 10	4	30 x 12	4	30 x 15	4
	18 x 6	5	36 x 10	5	36 x 12	5	36 x 15	5
	24 x 6	7	42 x 10	6	42 x 12	6	42 x 15	6
	30 x 6	9	48 x 10	7	48 x 12	7	48 x 15	7
	36 x 6	11	54 x 10	8	54 x 12	8	54 x 15	8
	48 x 6	15	60 x 10	9	60 x 12	9	60 x 15	9
	54 x 6	17	66 x 10	10	66 x 12	10	66 x 15	10
60 x 6	19	72 x 10	11	72 x 12	11	72 x 15	11	

DIMENSIONS IN INCHES (MM)	H	6 7/8 (175)	10 1/2 (267)	12 1/2 (318)	15 1/2 (384)
	A	8 1/2 (216)	12 1/8 (308)	14 1/8 (359)	17 1/8 (435)
	B	3 3/8 (86)	5 3/8 (137)	6 3/8 (162)	9 3/8 (238)
	C	3 (76)	6 (152)	6 (152)	6 (152)
	D	1 11/16 (43)	2 21/32 (67)	3 9/32 (83)	3 3/4 (95)
	E	4 1/2 (114)	6 1/4 (159)	7 1/8 (181)	8 3/4 (222)
	F	6 (152)	6 (152)	6 (152)	6 (152)
	G	-	6 (152)	6 (152)	9 (229)

**DESCRIPTION:**

1. Material: Extruded Aluminum.
2. Model 45DL1 is designed to handle large air capacities and provide long throws. It is ideally suited to applications where ductwork cannot be brought close to the occupants such as; shopping malls, industrial plants and stadiums.
3. Length of throw, direction and horizontal spread can be controlled by means of the rotating drum and pivoted adjustable vanes.
4. Felt seal around drum minimizes air leakage.
5. Standard finish is AW Appliance white.

**OPTIONS:**

- Opposed blade damper. Model 45DL1-0  
 (Note: Not recommended where static pressure drop across drum louver exceeds 0.25" w.g.).
  - PO Pole Operator
- Finish:
- AL Aluminum
  - MI Mill
  - SP Special \_\_\_\_\_

Dimensions are in inches (mm).

**SCHEDULE TYPE:**

**PROJECT:**

**ENGINEER:**

**CONTRACTOR:**

**DATE**

**B SERIES**

**SUPERSEDES**

**DRAWING NO.**

5 - 19 - 10

4500

24 - 2 - 00R

45DL1