

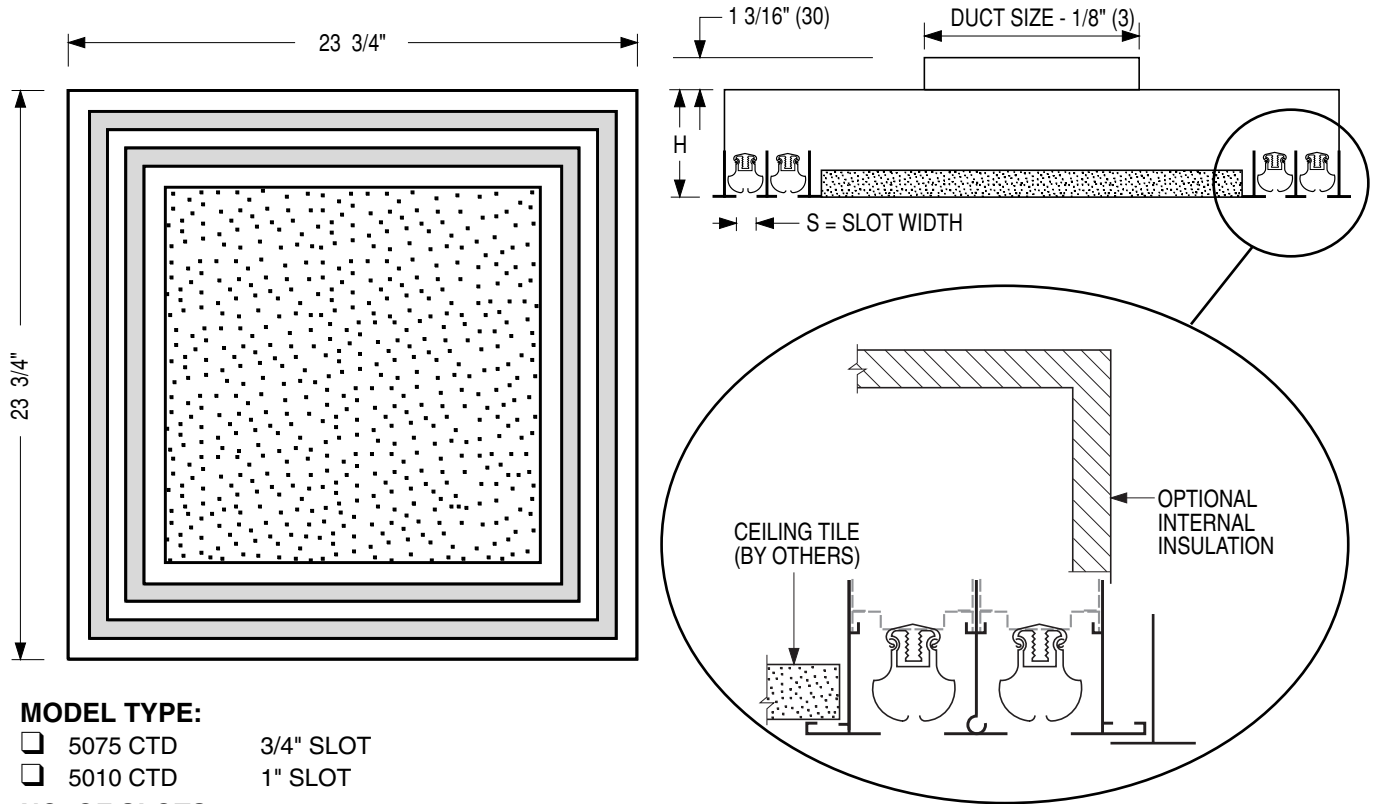

ARCHITECTURAL CEILING TILE SLOT DIFFUSER
SUPPLY • 24" x 24" MODULE
MODELS: 5075 CTD 3/4" SLOT
5010 CTD 1" SLOT

FOR STANDARD WIDTH AND NARROW GRID LAY-IN T-BAR CEILINGS



MODEL TYPE:

- 5075 CTD 3/4" SLOT
- 5010 CTD 1" SLOT

NO. OF SLOTS:

- 1 SLOT 3 SLOT
- 2 SLOT 4 SLOT

INLET SIZE:

- 6" 10" 14"
- 8" 12"

OPTIONS:

- Internal Insulation
- External Foil Back Insulation
- SP Special Paint Finish _____.

NO. OF SLOTS	CEILING TILE CUTTING DIMENSION		H DIM.
	3/4"	1"	
1	19 1/2 x 19 1/2	19 x 19	5
2	16 1/2 x 16 1/2	15 1/2 x 15 1/2	5
3	13 1/2 x 13 1/2	12 x 12	6 3/4
4	10 1/2 x 10 1/2	8 1/2 x 8 1/2	6 3/4

DESCRIPTION:

- The Nailor 5000 CTD Series has been designed with the architect in mind to provide an unobtrusive high performance ceiling diffuser that utilizes a center ceiling tile matching the surrounding ceiling system.
- The Nailor 'Ice Tong' Pattern Controllers are individually adjustable for each slot to provide a tight horizontal or vertical throw as well as volume control. The unit is ideally suited for use in VAV systems. Discharge patterns are fully field adjustable for 1-way, 2-way corner, 2-way opposite, 3-way or 4-way blow patterns.

- The 5000 CTD Series is designed for use with standard 15/16" T-bar and narrow 9/16" flat T-bar ceiling systems.
- MATERIAL:** Extruded aluminum face with staked and welded mitered corners. Steel pattern controllers and plenum. Plenum is easily removable for installation of ceiling tile (by others).
- FINISH:** AW Appliance white with flat black pattern controllers.

SCHEDULE TYPE:		Dimensions are in inches (mm).			
PROJECT:					
ENGINEER:	DATE	B SERIES	SUPERSEDES	DRAWING NO.	
CONTRACTOR:	10 - 13 - 09	5000	31 - 8 - 00RR	5000-CTD	