

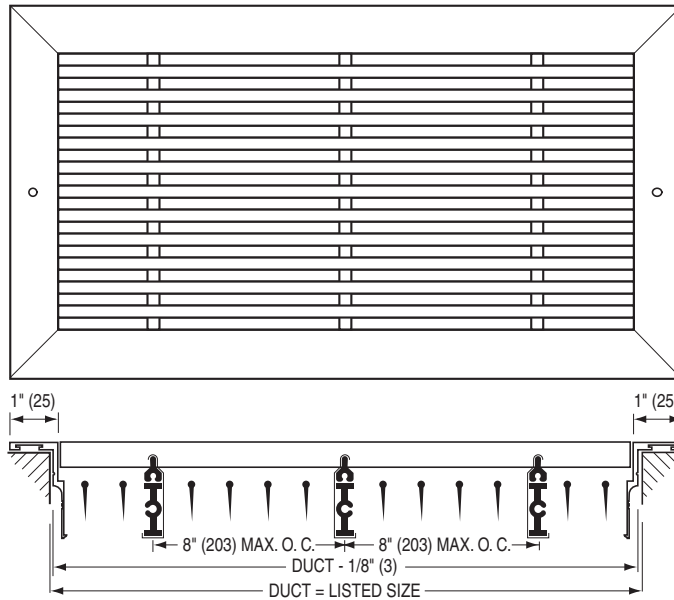

**ALUMINUM HEAVY DUTY BAR SUPPLY GRILLES  
GYMNASIUM**  
**MODELS: 51D30H-HD(-O), 51D30V-HD(-O),  
 51D15H-HD(-O), 51D15V-HD(-O), 51DFH-HD(-O)  
 AND 51DFV-HD(-O)**

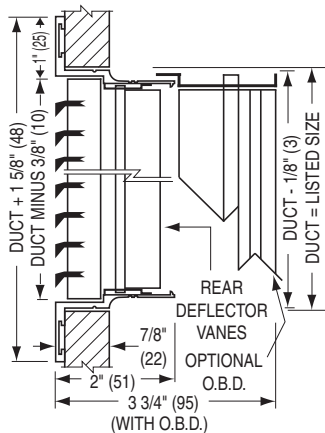

- MODEL 51D30H-HD**  
30° Horizontal Blades
- MODEL 51D30H-HD-O**  
30° Horizontal Blades  
(Includes O. B. Damper)
- MODEL 51D30V-HD**  
30° Vertical Blades
- MODEL 51D30V-HD-O**  
30° Vertical Blades  
(Includes O. B. Damper)
- MODEL 51D15H-HD**  
15° Horizontal Blades
- MODEL 51D15H-HD-O**  
15° Horizontal Blades  
(Includes O. B. Damper)
- MODEL 51D15V-HD**  
15° Vertical Blades
- MODEL 51D15V-HD-O**  
15° Vertical Blades  
(Includes O. B. Damper)
- MODEL 51DFH-HD**  
0° Horizontal Blades
- MODEL 51DFH-HD-O**  
0° Horizontal Blades  
(Includes O. B. Damper)
- MODEL 51DFV-HD**  
0° Vertical Blades
- MODEL 51DFV-HD-O**  
0° Vertical Blades  
(Includes O. B. Damper)



**Model 51D30H-HD  
Model 51D30H-HD-O**  
(Horizontal Shown)

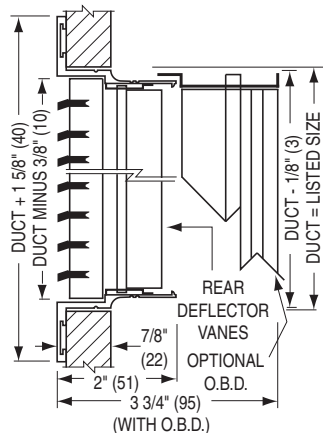

**Model 51D15H-HD  
Model 51D15H-HD-O**  
(Horizontal Shown)

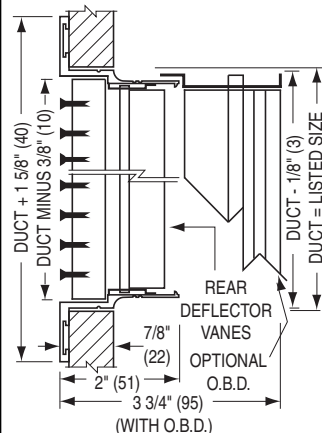

**Model 51DFH-HD  
Model 51DFH-HD-O**  
(Horizontal Shown)

**NOTES:**

1. Material: Heavy duty aluminum extrusions.
2. Construction: Heavy duty frame is staked and welded for maximum strength. Fixed front bars on 1/2" (13) centers are available in 30°, 15° or 0° deflection to suit air pattern requirement. 0° and 15° models feature 1/8" (3) bars and the 30° model features 1/4" (6) bars. All models are supplied with a set of friction pivoted rear vanes on 3/4" (19) centers that are individually adjustable for directional control and air pattern spread. Bars are reinforced and supported by an additional deep profile cross-bar. Spacing does not exceed 8" (203) on centers.
3. Optional opposed blade damper has a screwdriver adjustment accessible through the face of the register.
4. The minimum size is 8" x 4" (203 x 102).  
The maximum size is 48" x 36" (1219 x 914).

5. Standard fastening is Type A countersunk screw holes.
6. Standard finish is AW Appliance White.

**OPTIONS:**

Fastening:

- Type C Concealed mounting straps [36" x 36" (914 x 914) max.]

Finish:

- AL Aluminum
- SA Satin Anodized
- SP Special \_\_\_\_\_ .

Dimensions are in inches (mm).

**SCHEDULE TYPE:**

**PROJECT:**

**ENGINEER:**

**CONTRACTOR:**

DATE	B SERIES	SUPERSEDES	DRAWING NO.
2 - 1 - 11	5100	21 - 2 - 01R	5100-HD-2