

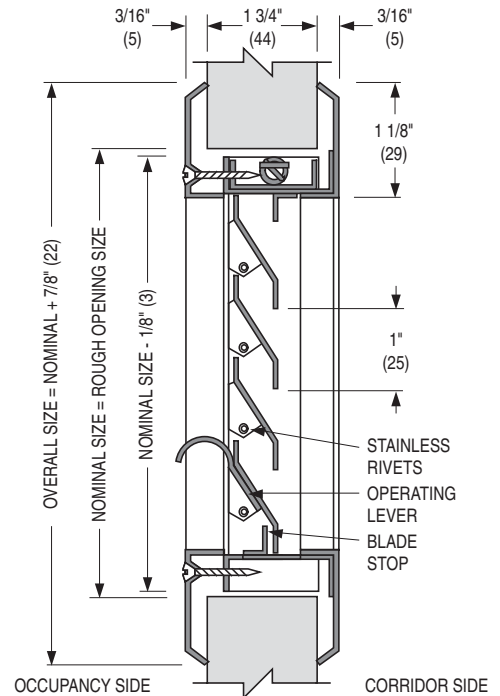

**STEEL FIRE RATED DOOR
GRILLE (LOUVER)
MODEL: 61DGD-FR**

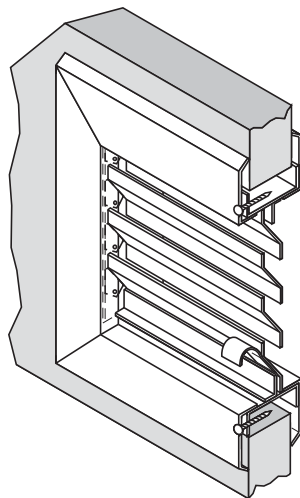
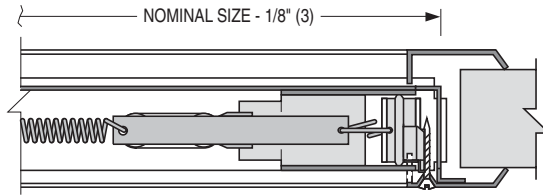

DESCRIPTION:

The 61DGD-FR is listed by Underwriters Laboratories for use in hollow metal and composite type fire doors with up to a 1 1/2 hr. rating. Suitable for doors 1 3/4" (44) thick.

- **Material:** 18 ga. cold rolled steel frame and blades.
- **Closing Assembly:** 160°F (71°C) UL listed fusible link with stainless steel operating spring and dead lock bar.
- **Installation:**
 - Door cutout size must be the same as order size of louver.
 - The door cutout may require the use of reinforcement per door manufacturer's listing.
 - Position the fusible link on top. Install both the grille and auxiliary frames simultaneously using the #8 x 1" long screws furnished. The grille handle and screwheads should be on the inside of the door (opposite corridor side).

– Tighten the Phillips head screws by hand. Power screwdrivers are not recommended.

Note: Nailor is not responsible for customer painted louvers, due to possible changes to operating condition.

- **Free Area:** 45%
- **Finish:** BP Dark Bronze primer
- **Available Sizes. In 2" (51) nominal increments:**
Minimum 12" x 6" (305 x 152).
Maximum 24" x 24" (610 x 610).
- **Quick Delivery Sizes:** 12" x 12", 18" x 12", 18" x 18", 24" x 12", 24" x 18", 24" x 24" (305 x 305, 457 x 305, 457 x 457, 610 x 305, 610 x 457, 610 x 610).

SCHEDULE TYPE:		Dimensions are in inches (mm).			
PROJECT:					
ENGINEER:	DATE	B SERIES	SUPERSEDES	DRAWING NO.	
CONTRACTOR:	2 - 1 - 11	6100	8 - 29 - 05	61DGD-FR	