

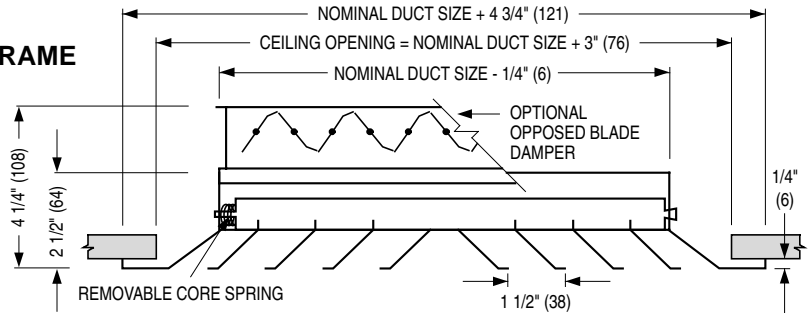

PATTERN CEILING DIFFUSERS
 ALUMINUM • SQUARE, RECTANGULAR OR
 ROUND NECK
MODELS: 6200 AND 6200-O TYPES S & B

TYPE S • SURFACE MOUNT • FLAT FRAME

Minimum duct size: 6 x 6 (152 x 152)
 Maximum duct size: 36 x 36 (914 x 914)
 or 36 x 24 (914 x 610) with O.B.D.
 Available in 3" (76) increments only.



TYPE B • BEVELED DROP FACE
 • SURFACE MOUNT

Minimum duct size: 6 x 6 (152 x 152)
 Maximum duct size: 36 x 36 (914 x 914)
 or 36 x 24 (914 x 610) with O.B.D.
 Available in 3" (76) increments only.

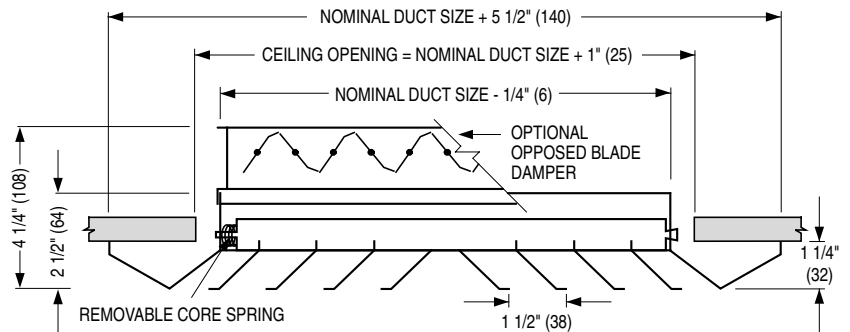

CORE STYLE SELECTION

	SQUARE	RECTANGULAR	
→ 1-WAY	□ 1S	□ 1A	□ 1B
↕ 2-WAY	□ 2S	□ 2A	□ 2B
↙ 2-WAY CORNER	□ 2G	□ 2E	□ 2F
↕ 3-WAY	□ 3A	□ 3A1 (A is greater than B)	□ 3A2 (B is less than A but greater than A/2)
	□ 3H	□ 3B (B is equal to A/2)	□ 3E (B is less than A/2)
	□ 4A	□ 4B	□ 4C
↕ 4-WAY			

Patterns are shown in plan view (looking down into inlet).

DESCRIPTION:

1. Material: Aluminum.
2. Model 6200 is a high capacity ceiling diffuser available in 1, 2, 3 or 4-way blow patterns to provide a tight horizontal airflow pattern from maximum to minimum airflow. Ideal for VAV applications.
3. Spring-loaded removable core.
4. Standard finish is AW Appliance White.

ACCESSORIES (OPTIONAL):

SQUARE AND RECTANGULAR NECK

- Steel opposed blade damper. Model 6200-O.
- Aluminum opposed blade damper. Model 6200-OA.

ROUND NECK

- SQR Square to round transition collar
- SQR-O Square to round transition collar for use over O.B.D.
- 4275 Radial Opposed Blade Damper (round)
- 4250 Radial Sliding Blade Damper (round)
- 4675 Butterfly Damper (round)

OPTIONAL FINISH:

- SP Special. Specify _____.

SCHEDULE TYPE:	Dimensions are in inches (mm).			
PROJECT:				
ENGINEER:	DATE	B SERIES	SUPERSEDES	DRAWING NO.
CONTRACTOR:	4 - 24 - 03	6200	7 - 4 - 00R	6200-1