

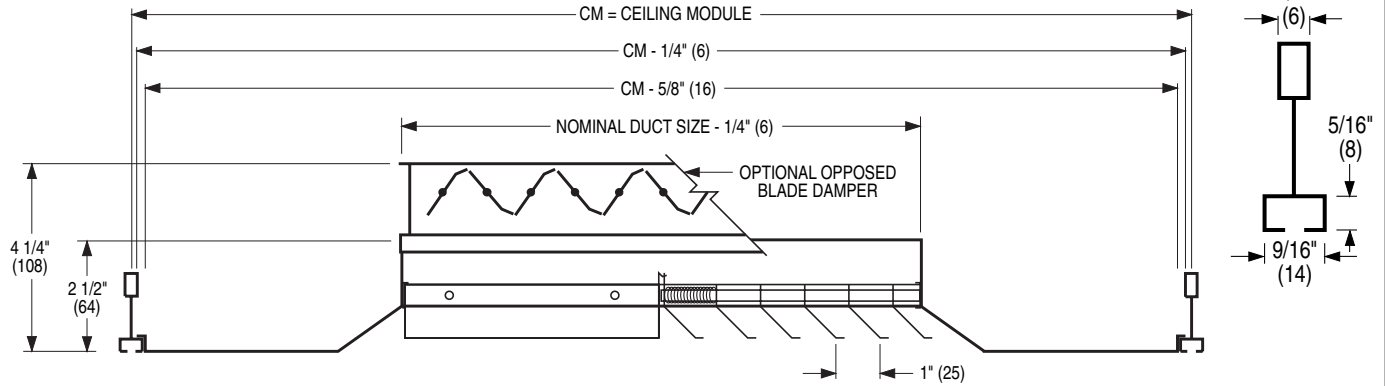

MODULAR CORE CEILING DIFFUSER
 1, 2, 3 OR 4-WAY ADJUSTABLE DISCHARGE
 PATTERN • SQUARE NECK • STEEL
 MODELS: 7500 AND 7500-O TYPE F

TYPE F FINELINE T-BAR



Ceiling Module CM			Available Duct Sizes
Imperial Modules		Metric Modules	
Imperial Units (inches)	SI Units (mm)	SI Units (mm)	
12 x 12	305 x 305	300 x 300	6 x 6 (152 x 152)
24 x 12	610 x 305	600 x 300	
20 x 20	508 x 508	500 x 500	6 x 6 (152 x 152) 9 x 9 (229 x 229) 12 x 12 (305 x 305) 15 x 15 (381 x 381)
24 x 24	610 x 610	600 x 600	8 x 8 (203 x 203) 10 x 10 (254 x 254) 14 x 14 (356 x 356)
			6 x 6 (152 x 152) 10 x 10 (254 x 254) 15 x 15 (381 x 381)
			8 x 8 (203 x 203) 12 x 12 (305 x 305) 16 x 16 (406 x 406)
			9 x 9 (229 x 229) 14 x 14 (356 x 356) 18 x 18 (457 x 457)

DESCRIPTION:

1. Material: Heavy gauge corrosion-resistant steel.
2. Model 7500 is a versatile ceiling diffuser. It consists of four spring loaded modular cores that may be simply adjusted by rotating each module after installation to provide a 1, 2, 3 or 4-way blow pattern. A tight horizontal air pattern from maximum to minimum flow makes it ideal for VAV applications.
3. Standard finish is AW Appliance White.

OPTIONS:

SQUARE NECK

- Opposed blade damper - Model 7500-O

ROUND NECK

- SQR Square to round transition collar
 SQR-O Square to round transition collar for use over opposed blade damper.
 _____ round neck size (inches)

- 4275 Radial damper
 4250 Radial sliding blade damper
 4675 Butterfly damper

OPTIONAL FINISH:

- SP Special. Specify _____ .

MODULAR CORE ADJUSTMENTS

(The Model 7500 is shipped with the core set for 4-way discharge).

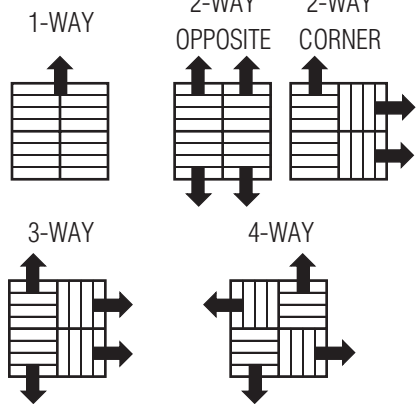

Dimensions are in inches (mm).

SCHEDULE TYPE:

PROJECT:

ENGINEER:

CONTRACTOR:

DATE	B SERIES	SUPERSEDES	DRAWING NO.
7 - 1 - 09	7500	11 - 5 - 07	7500-3B