

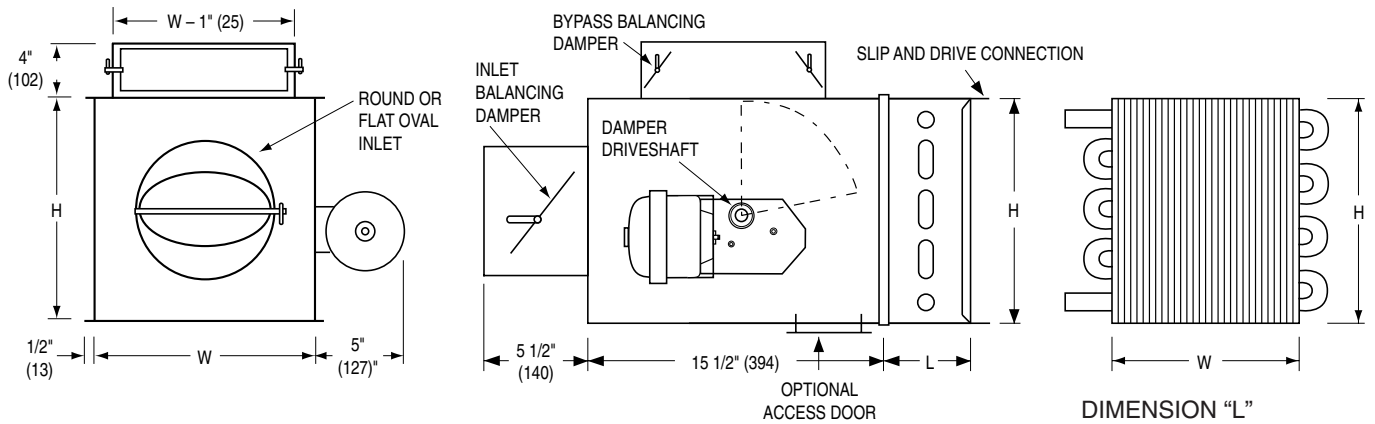

**BYPASS TERMINAL TERMINAL UNIT WITH
HOT WATER REHEAT
PNEUMATIC CONTROL
MODEL: P34RW MK II**



Dimensional Data

Imperial Units (inches)				
Unit Size	cfm Range	W	H	Inlet Size
6	0 - 400	10	12 1/2	5 7/8 Round
8	0 - 700	12	12 1/2	7 7/8 Round
10	0 - 1100	14	12 1/2	9 7/8 Round
12	0 - 1600	18	12 1/2	12 15/16 x 9 13/16 Oval
14	0 - 2100	24	12 1/2	16 1/16 x 9 13/16 Oval
16	0 - 2800	28	12 1/2	19 3/16 x 9 13/16 Oval

Metric Units (mm)				
Unit Size	l/s Range	W	H	Inlet Size
6	0 - 189	254	318	149 Round
8	0 - 330	305	318	200 Round
10	0 - 519	356	318	251 Round
12	0 - 755	457	318	329 x 249 Oval
14	0 - 991	610	318	408 x 249 Oval
16	0 - 1322	711	318	487 x 249 Oval



A Participating Corporation in the ARI 880 Certification program.

Standard Features:

- Casing - 22 ga. galvanized steel with round or flat oval inlets. Outlets are rectangular with slip and drive connections.
- Damper - Heavy gauge steel cylindrical "Flow Diverter" valve design for reliable long term operation. 90° rotation. CW to close.
- 1/2" (13) dia. plated steel driveshaft. An indicator mark on the end of the shaft shows damper position.
- 3/4" (19) dual density insulation. Exposed edges are coated to prevent airflow erosion. Material meets requirement of NFPA 90A and UL 181 standards.
- Inlet balancing damper.
- Adjustable bypass port balancing dampers.
- Tested in accordance with ANSI/ASHRAE Standard 130-1996 and ARI 880-98, in an independent test laboratory.

- Compact low profile design is ideally suited for installation in tight spaces.
- Right hand controls location is standard (shown) when looking in direction of airflow. Optional left hand controls mounting is available when damper is CCW to close.
- Bypass port may be removed for ducted return applications.
- Gauge tap for system balancing.

Hot Water Coil Section:

- 1/2" (13) Copper tubes and aluminum ripple fins, 10 per inch.
- 1, 2, 3 or 4 Row.
- Left or right hand connection. Determined by looking in direction of airflow (RH illustrated).
- Sweat connections: One row size 6 thru 14, 1/2" (13) O. D. male solder. Size 16 one row and all two, three and four row, 7/8" (22) O.D. male solder.

Controls:

- Pressure dependent pneumatic by Nailor. Direct drive rotary actuator MCP-3631 Series. Factory supplied and mounted (see separate submittal).
- By Others.

Options and Accessories:

- Round / Oval discharge collar.
- Bottom access door.
- Integral attenuator (Casing length changes from 15 1/2" (394) to 51 1/2" (1308) long plus "L" dimension).
- Multiple-outlet attenuator (see separate submittal).
- Special features: _____

SCHEDULE TYPE
PROJECT
ENGINEER
CONTRACTOR

Dimensions are in inches (mm).

DATE	B SERIES	SUPERSEDES	DRAWING NO.
10 - 01 - 01	3400	NEW	P34RW-1