

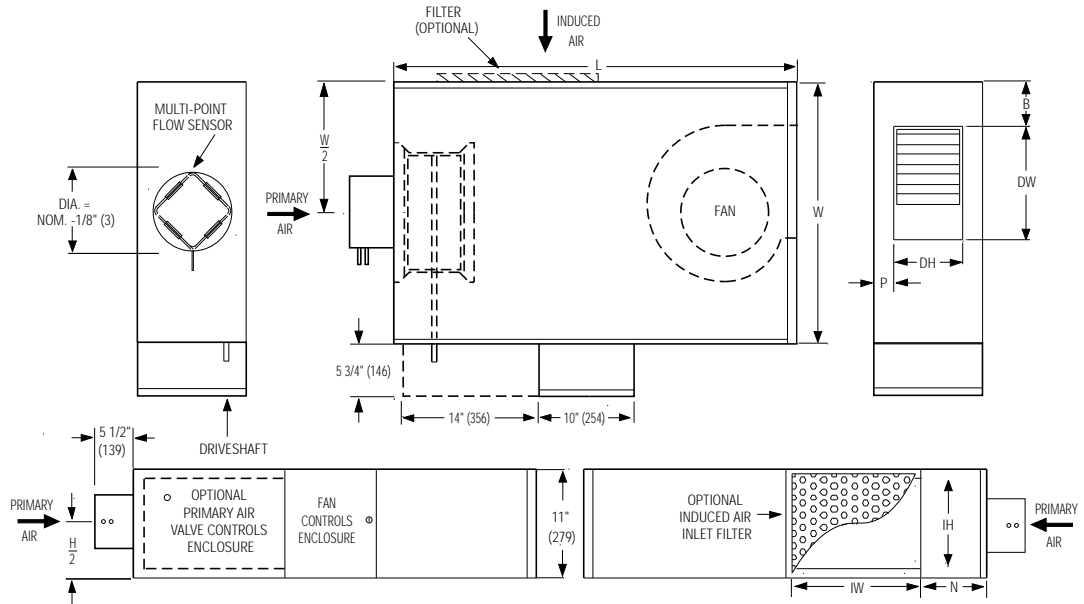

**LOW PROFILE FAN POWERED TERMINAL UNIT  
WITH ECM MOTOR  
SERIES FLOW • CONSTANT VOLUME  
MODELS: 37S, 37SW AND 37SE • UNIT SIZES 1 & 3**

**DESCRIPTION:**

- Only 11" (279) high.
- 20 ga. (1.0) galvanized steel construction.
- 16 ga. (1.6) galvanized steel inclined blade damper. 45° rotation. CW to close.
- Multi-point averaging Diamond Flow sensor.
- Access panels top and bottom.
- Ultra-high efficiency ECM fan motor. EPIC fan volume controller.
- 1/2" (13) dual density insulation, exposed edges coated to prevent air erosion. Meets requirements of NFPA 90A and UL 181.
- Single point electrical and/or pneumatic main air connection.
- Discharge opening for flanged duct connection.
- Full primary air valve low voltage enclosure for factory mounted DDC and analog electronic controls.
- Controls mounted as standard on RH side as shown. Terminals ordered with LH controls (optional) are inverted.



**Dimensional Data. Imperial Units (inches)**

Unit Size	Inlet Size	W	L	B	N	P	Induced Air Inlet IW x IH	Outlet Discharge DW x DH	Filter Size
1	4, 5, 6, 8	19	36	13/16	9	1 1/4	6 x 8	7 1/8 x 4 3/4	8 x 10
3	6, 8, 10	26 1/2	40 1/4	4 3/8	8	1 1/2	15 3/4 x 8	12 1/4 x 8	18 x 10

**Dimensional Data. Metric Units (mm)**

Unit Size	Inlet Size	W	L	B	N	P	Induced Air Inlet IW x IH	Outlet Discharge DW x DH	Filter Size
1	102, 127, 152, 203	483	914	21	229	32	152 x 203	181 x 121	203 x 254
3	152, 203, 254	673	1022	111	203	38	400 x 203	311 x 203	457 x 254

**OTHER OPTIONS:**

- Filter frame and 1" (25) disposable filter.
- Toggle disconnect switch.
- Steri-liner.
- Fiber-free liner.
- Solid metal liner.
- Perforated metal liner.
- Fan unit fusing.
- Hanger brackets.
- Left-hand controls location.
- Special features

**Electrical Data**

Unit Size	Motor H.P.	ECM FLA			
		120/1/60	208/1/60	240/1/60	277/1/60
1	*	1.7	1.1	1.1	1.0
3	*	5.1	3.6	3.4	2.9

\* The ECM is a variable horsepower motor. Refer to Selectwoks Schedule. FLA = Full load amperage



<b>SCHEDULE TYPE</b>					
<b>PROJECT</b>					
<b>ENGINEER</b>	<b>DATE</b>	<b>B SERIES</b>	<b>SUPERSEDES</b>	<b>DRAWING NO.</b>	
<b>CONTRACTOR</b>	4 - 20 - 10	3700	9 - 9 - 08	37S-3A	



**LOW PROFILE FAN POWERED TERMINAL UNIT  
WITH ECM MOTOR  
SERIES FLOW • CONSTANT VOLUME  
HEAT ACCESSORIES  
MODELS: 37SW AND 37SE • UNIT SIZES 1 & 3**

**Hot Water Coil Section Model 37SW**

**Standard Features:**

- Coil section installed on unit discharge.
- Coil (and header on multi-circuit units) is installed in insulated casing for increased thermal efficiency.
- 1/2" (13) copper tubes.
- Aluminum ripple fins.
- Sweat connections: One row 1/2" (13) O. D. male solder. Two and three row 7/8" (22) O.D. male solder.
- Top and bottom access panels for inspection and coil cleaning.
- Flanged outlet duct connection.

**Coil Rows:**

- 1-Row    2-Row    3-Row

**Coil Hand Connections:**

(Looking in direction of airflow).

- Right hand (illustrated). Standard.  
 Left hand. Optional.

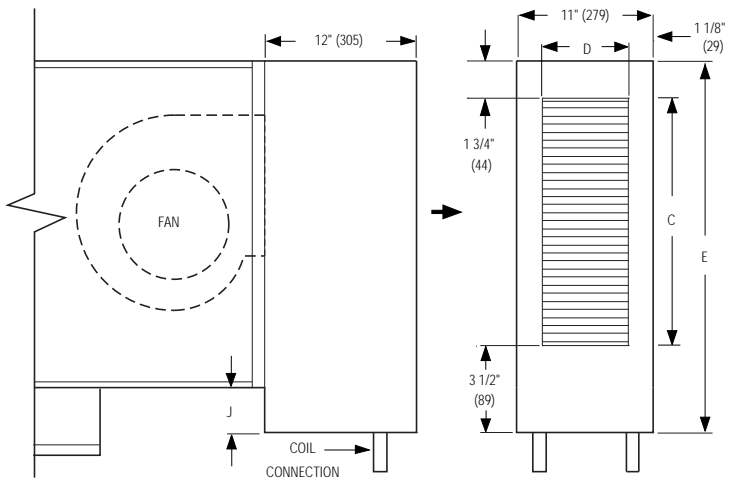

Unit Size	Imperial Units (inches)			Metric Units (mm)		
	Outlet Duct Size C x D	E	J	Outlet Duct Size C x D	E	J
1	14 3/4 x 8 3/4	20	1	375 x 222	508	25
3	23 7/8 x 8 3/4	29 1/8	2 5/8	606 x 222	740	67

**Electric Coil Section Model 37SE**

**Standard Features:**

- Controls enclosure incorporates a hinged access door opening upstream that helps ensure NEC clearance requirements and reduces footprint. (FN2 90° design is standard).
- Unique hinged heater design permits easy access, removal and replacement of heater element without disturbing ductwork.
- Coil installed on unit discharge.
- Insulated coil element wrapper.
- Automatic reset high limit cut-outs (one per element).
- Single point electrical connection for entire terminal unit.
- Positive pressure airflow switch.
- Flanged outlet duct connection.
- Terminal unit with coil is ETL Listed as an assembly.
- Controls mounted as standard on RH side as shown. Terminals ordered with LH controls (optional) are inverted.

**Voltage:**

Single phase, 60 Hz.

- 208V    240V    277V

Three phase, 60 Hz.

- 208V    480V (4 wire wye).    \_\_\_\_\_.

**Options:**

- Toggle disconnect switch (includes fan).
- Door interlock disconnect switch.
- Mercury contactors.
- Power circuit fusing.
- Class 'A' 80/20 Ni./Ch. wire.
- Dust tight construction.
- Manual reset secondary thermal cut out.

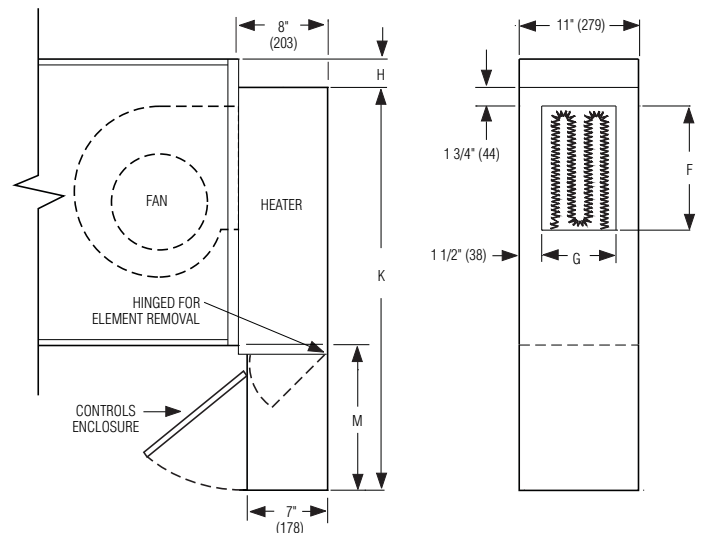

Unit Size	Imperial Units (inches)				Metric Units (mm)			
	Outlet Duct Size F x G	H	M	K	Outlet Duct Size F x G	H	M	K
1	10 1/4 x 8	1/2	16 1/8	34 5/8	260 x 203	12	410	879
3	12 1/4 x 8	3 1/2	17	40	311 x 203	89	432	1016

**SCHEDULE TYPE**

**PROJECT**

**ENGINEER**

**CONTRACTOR**

Page 2 of 2.  
Dimensions are in inches (mm).

**DATE**

**B SERIES**

**SUPERSEDES**

**DRAWING NO.**

4 - 20 - 10

3700

9 - 9 - 08

37S-3A