



LOW PROFILE FAN POWERED TERMINAL UNIT
'STEALTH' • SERIES FLOW • CONSTANT VOLUME
MODELS: 37SST, 37SEST AND 37SWST • UNIT SIZES 2 & 3
WITH 90° LINE VOLTAGE ENCLOSURE (FN2 OPTION)

DESCRIPTION:

- Only 11" (279) high.
- 20 ga. (1.0) galvanized steel construction.
- 16 ga. (1.6) galvanized steel inclined blade damper. 45° rotation. CW to close.
- "Stealth" tuned inlet attenuator.
- Multi-point averaging Diamond Flow sensor.
- Access panels on top and bottom.
- Energy efficient PSC fan motor with overload protection. Solid state fan speed controller with minimum voltage stop.
- 1/2" (13) dual density insulation, exposed edges coated to prevent air erosion. Meets requirements of NFPA 90A and UL 181.
- Single point electrical and / or pneumatic main air connection.
- Discharge opening for flanged duct connection.
- Full primary air valve low voltage enclosure for factory mounted DDC and analog electronic controls.
- FN2 line voltage enclosure incorporate a hinged access door opening upstream that helps ensure NEC clearance requirement and reduces footprint.
- Controls mounted as standard on RH side as shown. Terminals ordered with LH controls (optional) are inverted.

Model 37SST/Basic Unit

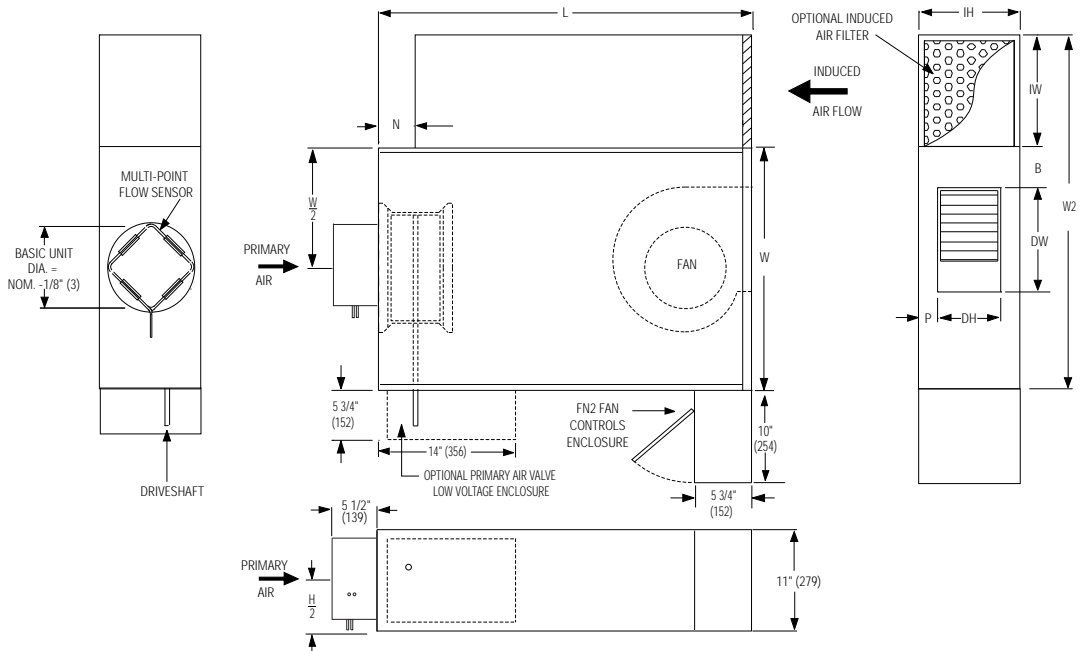

Dimensional Data. Imperial Units (inches)

Unit Size	Inlet Size	W	W2	L	B	N	P	Induced Air Inlet IW x IH	Outlet Discharge DW x DH	Filter Size
2, 3	6, 8, 10	26 1/2	38 1/2	40 1/4	4 3/8	6 1/4	1 1/2	12 x 11	12 1/4 x 8	12 x 11

Dimensional Data. Metric Units (mm)

Unit Size	Inlet Size	W	W2	L	B	N	P	Induced Air Inlet IW x IH	Outlet Discharge DW x DH	Filter Size
2, 3	152, 203, 254	673	978	1022	111	159	38	305 x 279	311 x 263	305 x 279

OTHER OPTIONS:

- Filter frame and 1" (25) disposable filter.
- Toggle disconnect switch.
- Steri-liner.
- Fiber-free liner.
- Solid metal liner.
- Perforated metal liner.
- Fan unit fusing.
- Hanger brackets.
- Left-hand controls location.
- Special features _____.

Electrical Data

Unit Size	Motor H.P.	PSC Motor FLA		
		120/1/60	208/1/60	277/1/60
2	1/6	4.8	1.8	1.5
3	1/4	5.8	3.6	1.8

FLA = Full load amperage



SCHEDULE TYPE				
PROJECT				
ENGINEER	DATE	B SERIES	SUPERSEDES	DRAWING NO.
CONTRACTOR	9 - 9 - 08	3700	2 - 13 - 06	37SST-5A



**LOW PROFILE FAN POWERED TERMINAL UNIT
'STEALTH' • SERIES FLOW • CONSTANT VOLUME
HEAT ACCESSORIES
MODELS: 37SST, 37SEST AND 37SWST • UNIT SIZES 2 & 3
WITH 90° LINE VOLTAGE ENCLOSURE (FN2 OPTION)**

Hot Water Coil Section Model 37SWST

Standard Features:

- Coil section installed on unit discharge.
- Coil (and header on multi-circuit units) is installed in insulated casing for increased thermal efficiency.
- 1/2" (13) copper tubes.
- Aluminum ripple fins.
- Sweat connections: One row 1/2" (13) O. D. male solder. Two and three row 7/8" (22) O.D. male solder.
- Top and bottom access panels for inspection and coil cleaning.
- Flanged outlet duct connection.

Coil Rows:

- 1-Row 2-Row 3-Row

Coil Connections:

- (Looking in direction of airflow).
- Right hand (illustrated). Standard.
 - Left hand (terminals are inverted). Optional.
- Connections must be selected same hand as controls enclosure location.

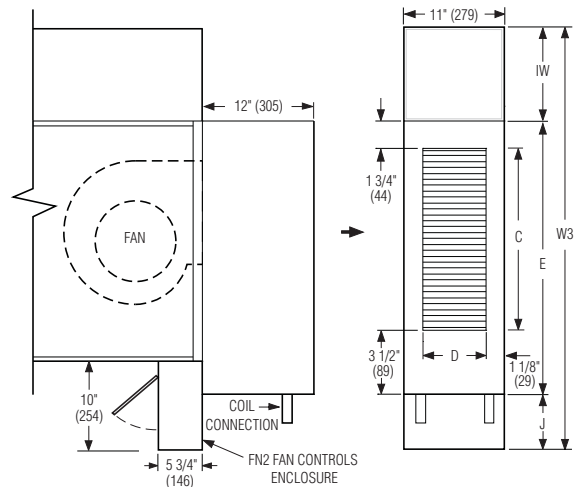

Unit Size	Imperial Units (inches)			Metric Units (mm)				
	Outlet Duct Size C x D	W3	E	J	Outlet Duct Size C x D	W3	E	J
2, 3	23 7/8 x 8 3/4	411/8	29 1/8	7 3/8	606 x 222	1045	740	187

Electric Coil Section Model 37SEST

Standard Features:

- Unique hinged heater design permits easy access, removal and replacement of heater element without disturbing ductwork.
- Coil installed on unit discharge.
- Insulated coil element wrapper.
- Automatic reset high limit cut-outs (one per element).
- Single point electrical connection for entire terminal unit.
- Positive pressure airflow switch.
- Flanged outlet duct connection.
- Terminal unit with coil is ETL Listed as an assembly.
- Controls mounted as standard on RH side as shown. Terminals ordered with LH controls (optional) are inverted.

Voltage:

Single phase, 60 Hz.

- 208V 240V 277V

Three phase, 60 Hz.

- 208V 480V (4 wire wye). _____

Options:

- Toggle disconnect switch (includes fan).
- Door interlock disconnect switch.
- Mercury contactors.
- Power circuit fusing.
- Class 'A' 80/20 Ni./Ch. wire.
- Dust tight construction.
- Manual reset secondary thermal cut out.

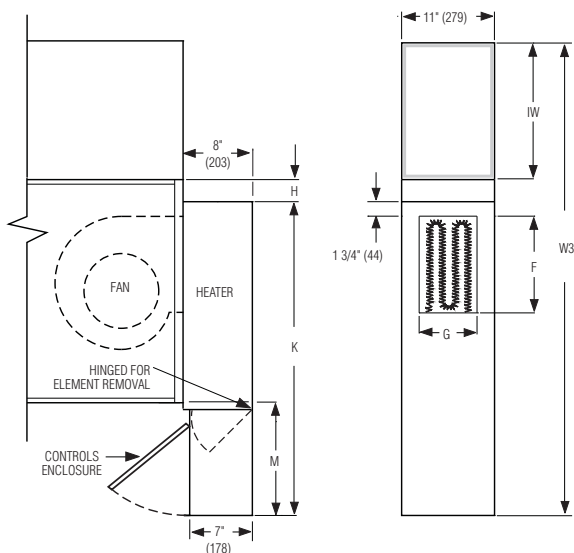

Unit Size	Imperial Units (inches)					Metric Units (mm)				
	Outlet Duct Size F x G	W3	H	M	K	Outlet Duct Size F x G	W3	H	M	K
2, 3	12 1/4 x 8	55 1/2	3 1/2	17	40	311 x 203	1410	89	432	1016

SCHEDULE TYPE

PROJECT

ENGINEER

CONTRACTOR

Page 2 of 2.

Dimensions are in inches (mm).

DATE

B SERIES

SUPERSEDES

DRAWING NO.

9 - 9 - 08

3700

10 - 01 - 01

37SST-5A