



LOW PROFILE FAN POWERED TERMINAL UNIT
'STEALTH' • SERIES FLOW • CONSTANT VOLUME
MODELS: 37SST, 37SWST AND 37SEST • UNIT SIZE 4
WITH 90° LINE VOLTAGE ENCLOSURE (FN2 OPTION)

DESCRIPTION:

- Only 11" (279) high.
- 20 ga. (1.0) galvanized steel construction.
- 16 ga. (1.6) galvanized steel inclined blade damper. 45° rotation. CW to close.
- "Stealth" tuned inlet attenuators (2). Shipped loose for field mounting.
- Multi-point averaging Diamond Flow sensor.
- Access panels on top and bottom.
- Energy efficient PSC fan motor with overload protection. Solid state fan speed controller with minimum voltage stop.
- 1/2" (13) dual density insulation, exposed edges coated to prevent air erosion. Meets requirements of NFPA 90A and UL 181.
- Single point electrical and/or pneumatic main air connection.
- Discharge opening for flanged duct connection.
- Full primary air valve low voltage enclosure for factory mounted DDC and analog electronic controls.
- FN2 line voltage enclosure incorporates a hinged access door opening downstream that helps ensure NEC clearance requirements and reduces footprint.
- Controls mounted as standard on RH side as shown. Terminals ordered with LH controls (optional) are inverted.

OTHER OPTIONS:

- Filter frame and 1" (25) disposable filters (2).
- Toggle disconnect switch.
- Steri-liner.
- Fiber-free liner.
- Solid metal liner.
- Perforated metal liner.
- Fan unit fusing.
- Hanger brackets.
- Left-hand controls location.
- Special features _____.

Model 37SST Basic Unit

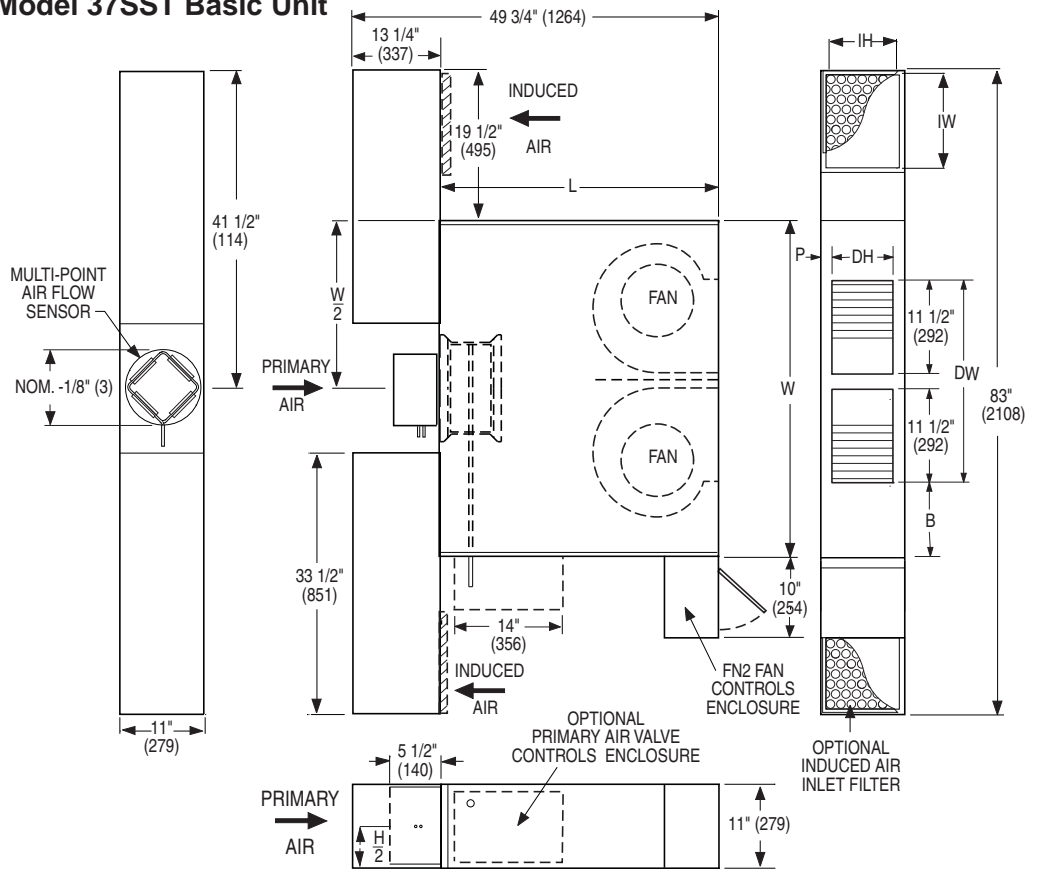

Dimensional Data. Imperial Units (inches)

Unit Size	Inlet Size	W	L	B	P	Induced Air Inlet IW x IH	Outlet Discharge DW x DH	Filter Size
4	10 Rnd. 14 x 10 Rect.	44	36 1/2	9 5/8	2	12 x 9 (2)	25 x 7	14 x 10 (2)

Dimensional Data. Metric Units (mm)

Unit Size	Inlet Size	W	L	B	P	Induced Air Inlet IW x IH	Outlet Discharge DW x DH	Filter Size
4	254 Rnd. 356 x 254 Rect.	1118	927	244	51	305 x 229 (2)	635 x 178	356 x 254 (2)

Electrical Data

Unit Size	Motor H.P.	PSC Motor FLA		
		120/1/60	208/1/60	277/1/60
4	2@1/4	11.6	7.2	3.7

FLA = Full load amperage



SCHEDULE TYPE	PROJECT	ENGINEER	CONTRACTOR	DATE	B SERIES	SUPERSEDES	DRAWING NO.
				5 - 27 - 09	3700	9 - 9 - 08	37SST-6A



**LOW PROFILE FAN POWERED TERMINAL UNIT
'STEALTH' • SERIES FLOW • CONSTANT VOLUME
HEAT ACCESSORIES
MODELS: 37SEST AND 37SWST • UNIT SIZE 4
WITH 90° LINE VOLTAGE ENCLOSURE (FN2 OPTION)**

Hot Water Coil Section Model 37SWST

Standard Features:

- Coil section installed on unit discharge.
- Coil (and header on multi-circuit units) is installed in insulated casing for increased thermal efficiency.
- 1/2" (13) copper tubes.
- Aluminum ripple fins.
- Sweat connections: One row 1/2" (13) O.D. male solder. Two and three row 7/8" (22) O. D. male solder.
- Top and bottom access panels for inspection and coil cleaning.
- Flanged outlet duct connection.

Coil Rows:

- 1-Row 2-Row 3-Row

Coil Hand Connections:

(Looking in direction of airflow).

- Left hand (illustrated). Standard.
 Right hand (terminals are inverted). Optional.

Connections must be selected opposite hand to FN2 controls enclosure location.

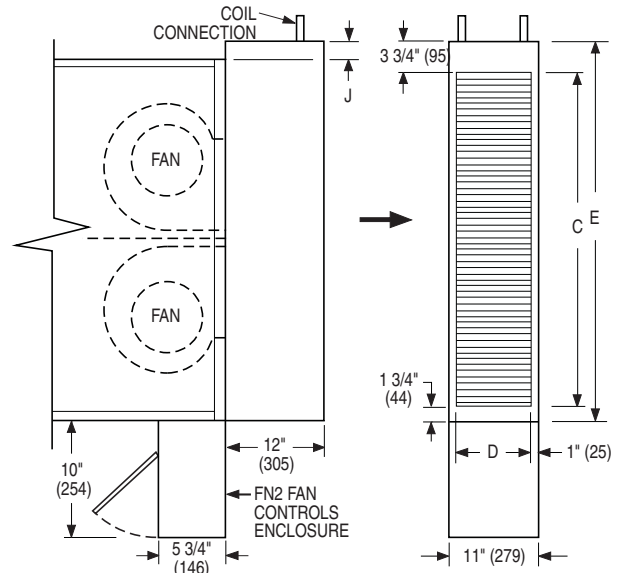

Unit Size	Imperial Units (inches)			Metric Units (mm)		
	Outlet Duct Size C x D	E	J	Outlet Duct Size C x D	E	J
4	40 3/4 x 9	46 1/4	2 1/4	1035 x 229	1175	57

Electric Coil Section Model 37SEST

Standard Features:

- Unique hinged heater design permits easy access, removal and replacement of heater element without disturbing ductwork.
- Coil installed on unit discharge.
- Insulated coil element wrapper.
- Automatic reset high limit cut-outs (one per element).
- Single point electrical connection for entire terminal unit.
- Positive pressure airflow switch.
- Flanged outlet duct connection.
- Terminal unit with coil is ETL Listed as an assembly.
- Controls mounted as standard on RH side as shown. Terminals ordered with LH controls (optional) are inverted.

Voltage:

Single phase, 60 Hz.

- 208V 240V 277V

Three phase, 60 Hz.

- 208V 480V (4 wire wye). _____

Options:

- Toggle disconnect switch (includes fan).
- Door interlock disconnect switch.
- Mercury contactors.
- Power circuit fusing.
- Class 'A' 80/20 Ni./Ch. wire.
- Dust tight construction.
- Manual reset secondary thermal cut out.

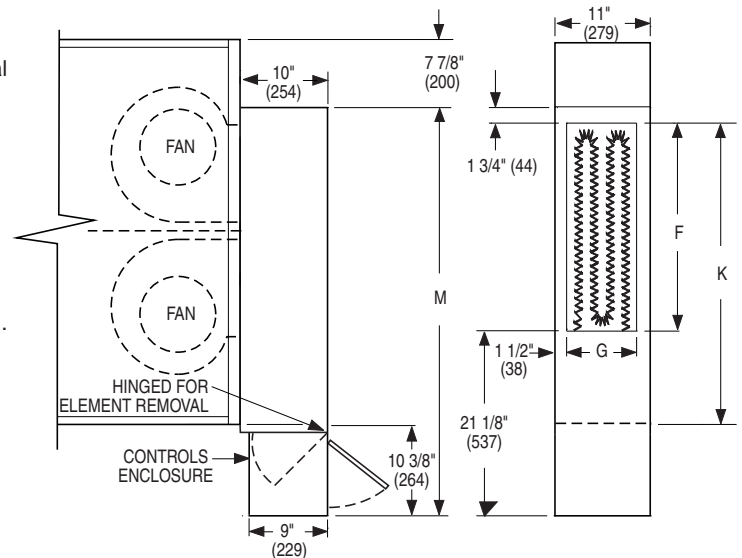

Unit Size	Imperial Units (inches)			Metric Units (mm)		
	Outlet Duct Size F x G	M	K	Outlet Duct Size F x G	M	K
4	23 5/8 x 8	46 1/2	34 3/8	600 x 203	1181	873

SCHEDULE TYPE					
PROJECT					
ENGINEER	DATE	B SERIES	SUPERSEDES	DRAWING NO.	
CONTRACTOR	5 - 27 - 09	3700	9 - 9 - 08	37SST-6A	