

30HQ SERIES • HOSPITAL GRADE SINGLE DUCT TERMINALS



Nailor[®]
Industries Inc.

Contents

	Page No.
Product Overview • 30HQ Series	1
Introduction and Features	
30HQ • Cooling or Heating Only	2
30HQW • Cooling with Hot Water Reheat	
30HQE • Cooling with Electric Reheat	
Dimensional Data	
30HQ • Basic Unit	3
Pneumatic Controls	
Analog Electronic and Digital Controls	
30HQW • Hot Water Reheat Coil	
30HQE • Integral Electric Reheat	4
Liner	
Recommended Airflow Ranges	5
Performance Data	
Performance Data Explanation	6
NC Level Application Guide	7
Discharge Sound Power Levels	8
Radiated Sound Power Levels	9
AHRI Certification and Performance Notes	10
Suggested Specifications	11

30HQ SERIES • HOSPITAL GRADE • QUIET TYPE WITH DISSIPATIVE SILENCER



PRODUCT OVERVIEW

MODELS: 30HQ, 30HQW AND 30HQE

Nailor 30HQ Series Single Duct Hospital Grade Terminal units control the flow of conditioned primary air into a constant or variable air volume (VAV) HVAC system. There are three versions of the 30HQ Series: the standard cooling unit (30HQ), a cooling with water reheat unit (30HQW) and a cooling unit with electric reheat (30HQE). Each unit is comprised of a VAV section and dissipative silencer, providing an assembly ideal for IAQ sensitive hospital applications.

The 30HQ Series share design features with the 3000 Series of terminal units. Features include an opposed blade damper (OBD), rectangular discharge, multi-point averaging Diamond flow sensor and various control options. Because hospital maintenance and sanitation guidelines differ from typical applications, the 30HQ Series include options like access doors and removable flow sensors. Optional access doors are strategically placed to allow for damper or coil access.

All 30HQ Series units include a factory installed dissipative silencer designed to provide minimal impact on system pressure drop while simultaneously delivering superior sound attenuation. By combining optimized internal baffling, mylar encapsulated fiberglass media and an acoustical separator, the silencer provides excellent attenuation in the 2nd and 3rd octave bands and reduces self-generated sound. 30HQ Series VAV sections are lined with Steri-Liner, a rigid fiberglass with a reinforced aluminum FSK facing. This insulation provides excellent sound attenuation, has a durable cleanable surface and serves to transition the incoming velocity profile into the dissipative silencer. The silencer, in addition to the baffles, mylar and fiberglass, contains Steri-Liner on the top and bottom to eliminate the need for field applying thermal duct wrap.

30HQ Series Units allow for field or factory mounting of specific controls. Many of the control options, working in conjunction with the supplied Diamond FLOW Sensor, allow the Terminal to monitor the desired flow rate. When a change in the flow rate is detected the controller instantly compensates, providing a unit that is pressure independent for use in a variable air volume application.

Calculations and guesswork typically associated with properly selecting a terminal / silencer combination can be cumbersome. Since each 30HQ Series unit is designed, manufactured and tested as a complete assembly, this extra labor is eliminated, providing accurate performance data.



30HQ Cooling or Heating only

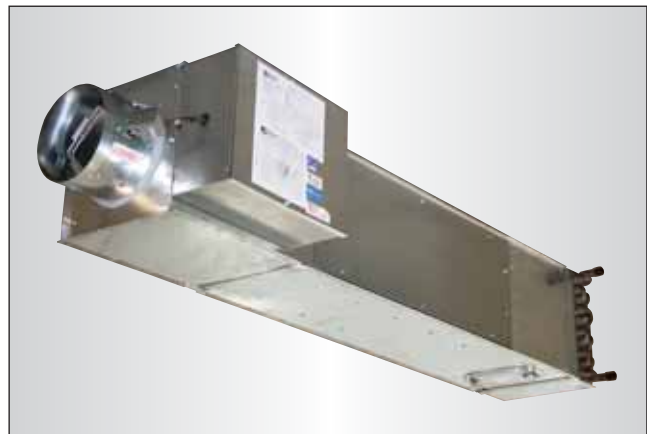

30HQW Cooling with Hot Water Reheat



30HQE Cooling with Electric Reheat

SINGLE DUCT VARIABLE OR CONSTANT AIR VOLUME

30HQ SERIES

- HOSPITAL GRADE
- DISSIPATIVE SILENCER
- SUPER QUIET

Models:

- 30HQ** Cooling or Heating only
- 30HQW** Cooling with Hot Water Reheat
- 30HQE** Cooling with Electric Reheat

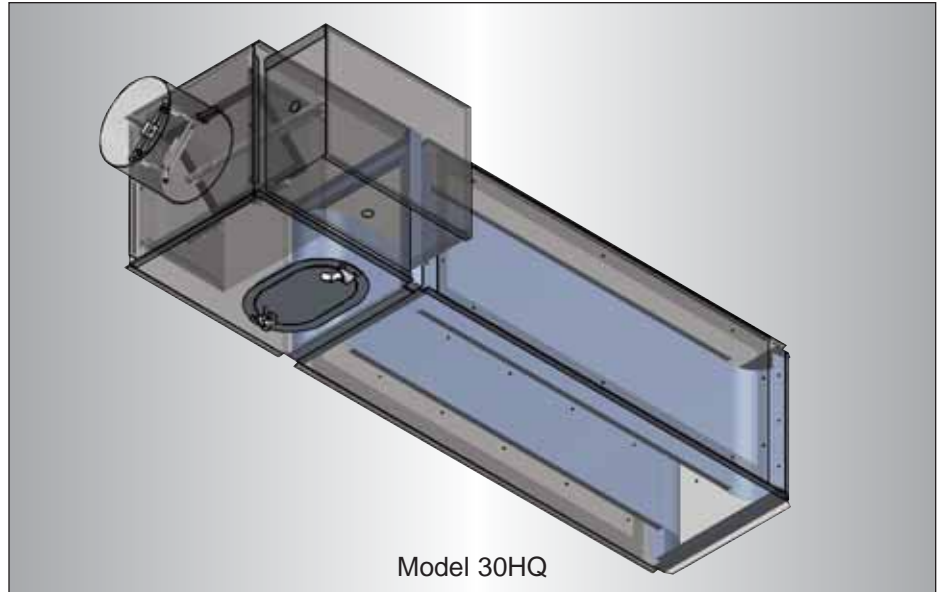

Hospital system designs have to contend with the presence of infectious diseases, chemical hazards, biological contaminants and low sound level requirements. The 30HQ hospital grade terminal unit has been purposely designed to address these parameters by using innovative options and construction methods, resulting in simplified maintenance and improved sound performance.

Each unit includes a factory mounted dissipative silencer that maximizes acoustical attenuation, minimizes pressure loss and reduces self-generated sound. Acoustic insulation in the silencer is wrapped in mylar, which acts to isolate the fiberglass from the airstream. Mylar also works as a vapor barrier preventing mold and bacterial growth in the acoustic media. FSK (Foil-Scrim-Kraft) faced Steri-Liner is the only liner available on the 30HQ series. This insulation offers a durable, cleanable surface throughout the VAV section and exposed silencer portions. By fully lining the silencer, there is no need to field apply external thermal duct wrap. Optional components such as access doors and removable flow sensors enhance the functionality of the 30HQ Series units to provide optimum performance and flexibility in hospital environments.

STANDARD FEATURES:

- Designed for hospital and other critical environment applications where IAQ (Indoor Air Quality) is a concern.
- 22 ga. (0.86) galvanized steel casing, mechanically sealed, low leakage construction.
- 16 ga. (1.63) corrosion-resistant steel inclined opposed blade damper with extruded PVC seals (single blade on size 4, 5, 6). 45° rotation, CW to close. Tight close-off. Damper leakage is less than 2% of the terminal rated airflow at 3" w.g. (750 Pa)
- 1/2" (13) dia. Plated steel drive shaft. An indicator mark on the end of the shaft shows damper position.
- Multi-point averaging Diamond Flow Sensor. Aluminum construction. Supplied with balancing tees.
- Rectangular discharge with slip and drive cleat duct connection.
- Full NEMA 1 type controls enclosure for factory mounted controls.

- VAV section is lined with 13/16" (21) thick, 4 lb. density Steri-Liner insulation. Fiberglass with a reinforced aluminum FSK facing. Meets the requirements of NFPA 90A, UL 181 and ASTM C655.
- "Notch and tuck" fabrication and full seam length steel Z-Strip construction.
- Right-hand controls location is standard (shown) when looking in direction of airflow. Optional left hand controls mounting is available.
- Available in 11 sizes ranging from 0 to 6800 cfm (0-3209 l/s) for 30HQ and 30HQW units. 25-6800 cfm (12-3209 l/s) on 30HQE.

Silencer Section:

- Designed to mate with VAV section for optimum performance and super quiet operation.
- Optimized internal baffle geometry reduces self-generated noise, maximizes acoustic attenuation.
- 22 ga. (0.86) coated steel perforated baffles encapsulate fiberglass acoustic media. Mylar lining with acoustical spacer isolates material from airstream.

- Internal Steri-Liner insulation on top and bottom optimizes sound reduction and eliminates need for external field applied thermal duct wrap.

Options and Accessories:

- Bottom access door
- FMI Removable insert type Diamond Flow Sensor.
- 24 VAC control transformer.
- Toggle disconnect switch.
- Hanger brackets.
- Controls enclosure for field mounted controls.
- Dust tight enclosure seal.
- 20 ga. (1.00) construction



Dimensions

Model Series 30HQ • Hospital Grade • Dissipative Silencer

Pneumatic Controls

- Universal pneumatic control mounting panel features double wall stand-off construction for strength and rigidity. Controls mounting screws do not penetrate terminal casing.

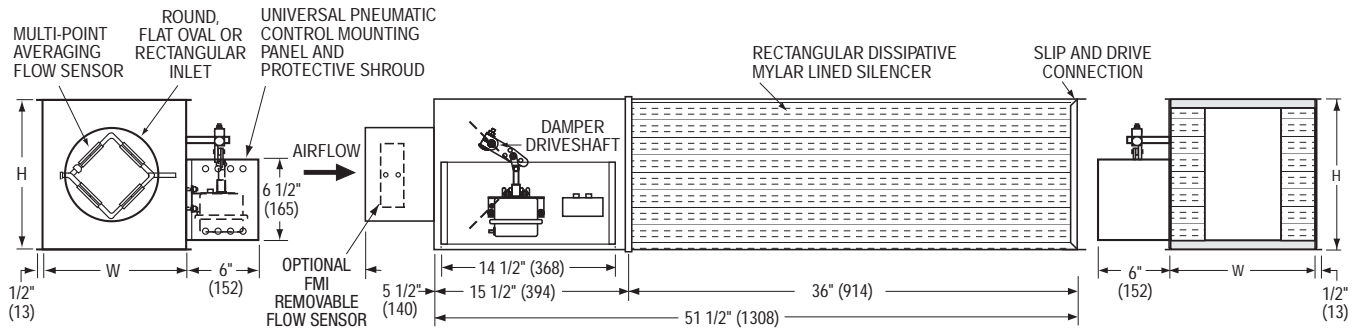

Analog Electronic and Digital Controls

- A full NEMA 1 controls enclosure is provided for factory mounted controls. Optional for field mounted controls.

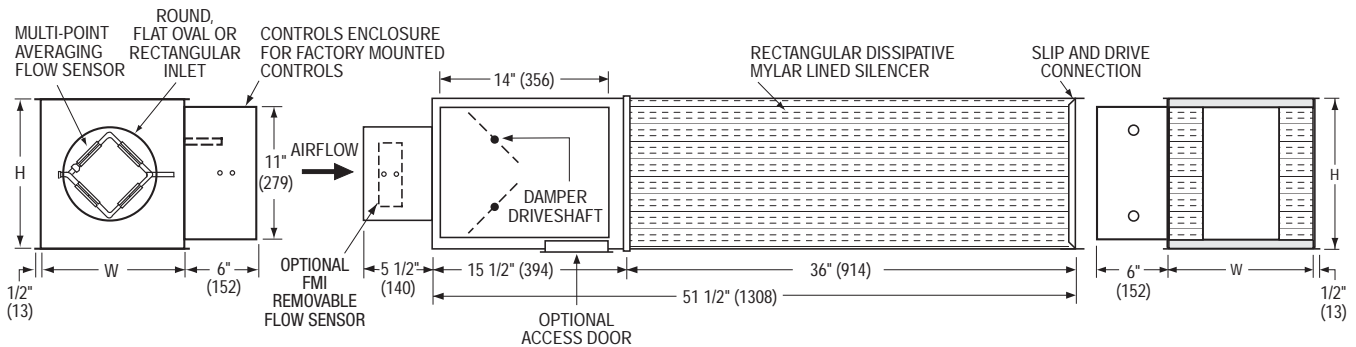

30HQW • Hot Water Reheat Coils

- One, two, three and four row available.
- Hot water coils have copper tubes and aluminum ripple fins. Coils have 1/2" (13), 7/8" (22) or 1 3/8" (35) O.D. sweat connections. Right or left hand coil connection is determined by looking through the terminal inlet in the direction of airflow.
- Galvanized steel casing with slip and drive discharge duct connection.
- Optional low leakage gasketed access door is recommended for coil access and cleaning.
- AHRI Certified.
- Coil Performance data on pages B19-B27.

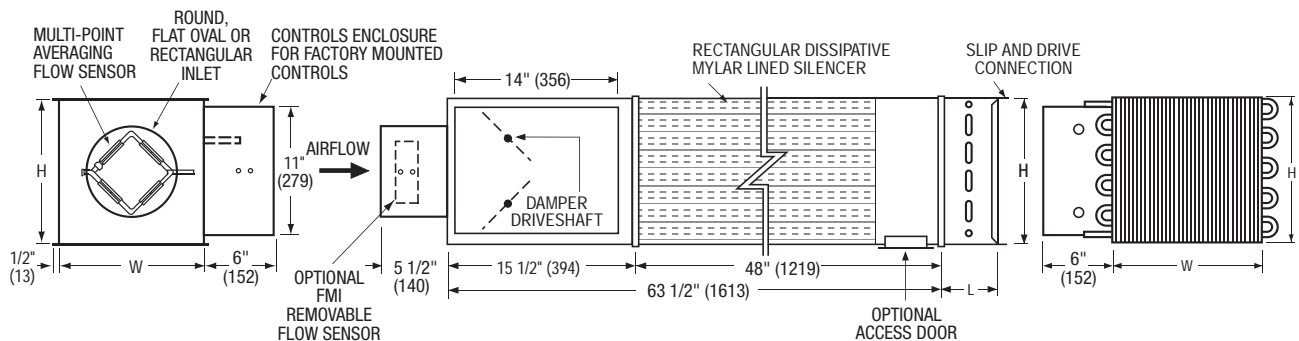

Dimensions

Model Series 30HQ • Hospital Grade • Dissipative Silencer

30HQE • Integral Electric Reheat

- Electric coil is factory mounted in an integral extended plenum section.
- Perforated diffuser plate minimizes air stratification.
- Full details and selection guide on page B28.

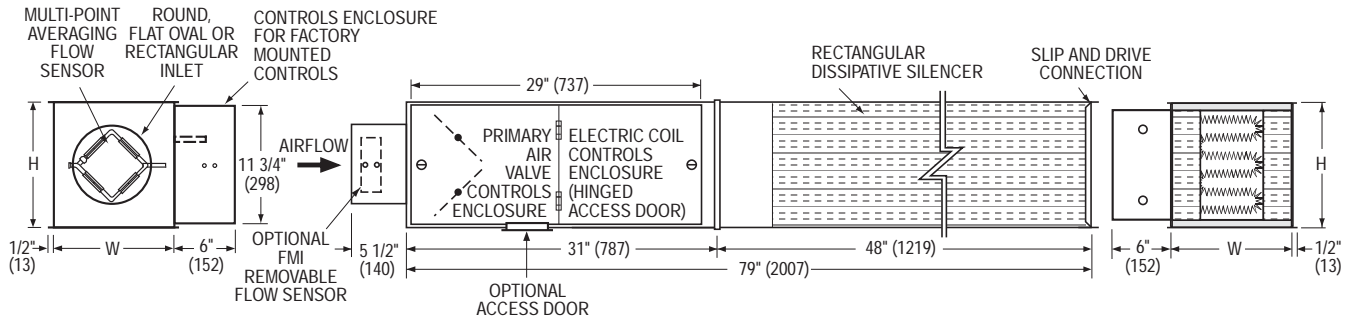

Dimensional Data

Unit Size	Airflow Range cfm (l/s)	W	H	Inlet Size	Hot Water Coil	
					L (1 & 2 row)	L (3 & 4 row)
4	0 – 180 (0 – 85)	10 (254)	10 (254)	3 7/8 (98) Round	5 (127)	7 1/2 (191)
5	0 – 325 (0 – 153)	10 (254)	10 (254)	4 1/4 (124) Round	5 (127)	7 1/2 (191)
6	0 – 450 (0 – 212)	10 (254)	10 (254)	5 1/4 (149) Round	5 (127)	7 1/2 (191)
7	0 – 650 (0 – 307)	12 (305)	12 1/2 (318)	6 1/4 (175) Round	5 (127)	7 1/2 (191)
8	0 – 900 (0 – 425)	12 (305)	12 1/2 (318)	7 1/4 (200) Round	5 (127)	7 1/2 (191)
9	0 – 1150 (0 – 543)	14 (356)	12 1/2 (318)	8 1/4 (225) Round	5 (127)	7 1/2 (191)
10	0 – 1500 (0 – 708)	14 (356)	12 1/2 (318)	9 1/4 (251) Round	5 (127)	7 1/2 (191)
12	0 – 2050 (0 – 967)	18 (457)	12 1/2 (318)	12 1/4 x 9 1/4 (329 x 249) Oval	5 (127)	7 1/2 (191)
14	0 – 2550 (0 – 1203)	24 (610)	12 1/2 (318)	16 1/4 x 9 1/4 (408 x 249) Oval	5 (127)	7 1/2 (191)
16	0 – 3040 (0 – 1435)	28 (711)	12 1/2 (318)	19 3/4 x 9 1/4 (487 x 249) Oval	5 (127)	7 1/2 (191)
24 x 16	0 – 6800 (0 – 3209)	38 (965)	18 (457)	23 1/4 x 15 1/4 (606 x 403) Rect.	5 (127)	7 1/2 (191)

HOSPITAL GRADE LINER

Model 30HQ Hospital Grade terminal units include as standard Steri-Liner in the VAV section. The top and bottom of the dissipative silencer is lined with Steri-Liner while the sides are lined with fiberglass wrapped in a mylar liner and then covered with perforated metal baffles. An acoustical spacer separates the mylar from the internal baffles and functions to attenuate sound levels in the 2nd and 3rd octave bands. The 30HQ Series terminal units do not require field applied thermal duct wrap.

- Fiberglass acoustic media in silencer, wrapped in mylar for protection and isolation.
- Steri-liner in terminal unit and top and bottom of silencer selection. 13/16" (21) thick, 4 lb./cu. ft (64 kg/m³) rigid fiberglass with fire resistant reinforced aluminum foil-scrim-kraft (FSK) facing.
- 22 ga. (0.86) coated acoustically transparent perforated metal silencer baffles with solid elliptical nose piece.
- Mylar film

Meets the following requirements:

- NFPA 90A and 90B
- UL 181
- UL 723
- UL 94 (mylar)
- ASTM E 84, C 665, C 1338, C 1071

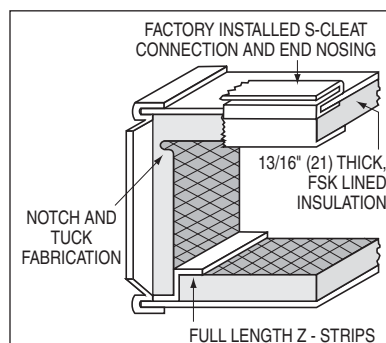

VAV Section Liner detail

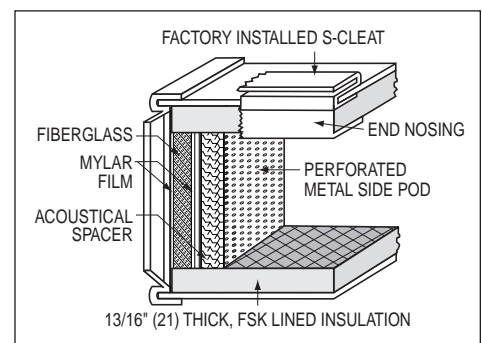

Silencer Liner detail

Recommended Airflow Ranges For Single Duct VAV Terminal Units

The recommended airflow ranges below are for terminal units with pressure independent controls and are based upon controller sensitivity limits as shown for each control type. For a given unit size, the minimum, auxiliary minimum (where applicable) and the maximum flow settings must be within the range limits to ensure pressure independent operation, accuracy and repeatability. The high end of the tabulated Total Airflow Range represents the Diamond Flow Sensor's differential pressure reading at 1" w.g. (250 Pa). This is a common high limit for many VAV controllers, whether pneumatic or analog/DDC transducers. Minimum airflow limits are based upon 0.02" w.g. (5 Pa) differential pressure signal from Diamond Flow Sensor (0.03" w.g. (7.5 Pa) for pneumatic controller). This is a realistic low limit for many transducers used in the digital controls industry. For these reasons, factory settings will not be made outside these ranges. A minimum setting of zero (shut-off) is also available. Where an auxiliary setting is specified, the value must be greater than the minimum setting.

AHRI Standard 880 "Performance Rating of Air Terminals" is the method of test for the certification



program. The "standard rating condition" (certification rating point) airflow volumes for each terminal unit size are tabulated below. These air volumes equate to an approximate inlet velocity of 2000 fpm (10.2 m/s).

When digital or other controls are mounted by Nailor, but supplied by others, these values are guidelines only, based upon experience with the majority of controls currently available. Controls supplied by others for factory mounting are configured and calibrated in the field.

Imperial Units, Cubic Feet per Minute

Unit Size	Total Airflow Range cfm	Airflow at 2000 fpm Inlet Velocity (nom.) cfm	Range of Minimum and Maximum Settings, cfm		
			Pneumatic 3000 Controller	Analog Electronic Controls	Digital Controls
			Min. – Max.	Min. – Max.	Min. – Max.
4	0 – 180	150	30 – 180	25 – 180	25 – 180
5	0 – 325	250	55 – 325	45 – 325	45 – 325
6	0 – 450	400	80 – 450	65 – 450	65 – 450
7	0 – 650	550	115 – 650	95 – 650	95 – 650
8	0 – 900	700	155 – 900	125 – 900	125 – 900
9	0 – 1150	900	200 – 1150	165 – 1150	165 – 1150
10	0 – 1500	1100	260 – 1500	215 – 1500	215 – 1500
12	0 – 2050	1600	355 – 2050	290 – 2050	290 – 2050
14	0 – 2550	2100	440 – 2550	360 – 2550	360 – 2550
16	0 – 3040	2800	525 – 3040	430 – 3040	430 – 3040
24 x 16	0 – 6800	5350	1180 – 6800	960 – 6800	960 – 6800

Metric Units, Liters per Second

Unit Size	Total Airflow Range l/s	Airflow at 10.2 m/s Inlet Velocity (nom.) l/s	Range of Minimum and Maximum Settings, l/s		
			Pneumatic 3000 Controller	Analog Electronic Controls	Digital Controls
			Min. – Max.	Min. – Max.	Min. – Max.
4	0 – 85	71	14 – 85	12 – 85	12 – 85
5	0 – 153	118	26 – 153	21 – 153	21 – 153
6	0 – 212	189	38 – 212	31 – 212	31 – 212
7	0 – 307	260	54 – 307	45 – 307	45 – 307
8	0 – 425	330	73 – 425	59 – 425	59 – 425
9	0 – 543	425	94 – 543	78 – 543	78 – 543
10	0 – 708	519	123 – 708	101 – 708	101 – 708
12	0 – 967	755	168 – 967	137 – 967	137 – 967
14	0 – 1203	991	208 – 1203	170 – 1203	170 – 1203
16	0 – 1435	1321	248 – 1435	203 – 1435	203 – 1435
24 x 16	0 – 3209	2525	557 – 3209	453 – 3209	453 – 3209

Performance Data Explanation

Sound Power Levels vs. NC Levels

The **Nailor 30HQ Series** single duct terminal unit performance data is presented in two forms.

The laboratory obtained discharge and radiated sound power levels in octave bands 2 through 7 (125 through 4000 Hz) center frequency for each unit size at various flow rates and inlet static pressures is presented. This data is derived in accordance with ANSI/ASHRAE Standard 130-2008 and AHRI Standard 880-2008. This data is "raw" with no attenuation deductions and includes AHRI Certification standard rating points.

Nailor also provides an "NC Level" table as an application aid in terminal selection, which include attenuation allowances as explained below. The suggested attenuation allowances are typical and are not representative of specific job site conditions. It is recommended that the sound power level data be used and a detailed NC calculation be performed using the procedures outlined in AHRI 885-2008 for accurate space sound levels.

Explanation of NC Levels

Tabulated NC levels are based on attenuation values as outlined in AHRI Standard 885-2008 "Procedure for Estimating Occupied Space Sound Levels in the Application of Air Terminals and Air Outlets". AHRI Standard 885-2008, Appendix E provides typical sound attenuation values for air terminal discharge sound and air terminal radiated sound.

As stated in AHRI-885-2008, Appendix E, "These values can be used as a quick method of estimating space sound levels when a detailed evaluation is not available. The typical attenuation values are recommended for use by manufacturers to estimate application sound levels. In product catalogs, the end use environments are not known and the following factors are provided as typical attenuation values. Use of these values will allow better comparison between manufacturers and give the end user a value which will be expected to be applicable for many types of space."

Radiated Sound

Table E1 of Appendix E provides typical radiated sound attenuation values for three types of ceiling: Type 1 – Glass Fiber; Type 2 – Mineral Fiber; Type 3 – Solid Gypsum Board. Since Mineral Fiber tile ceilings are the most common construction used in commercial buildings, these values have been used to tabulate Radiated NC levels.

The following table provides the calculation method for the radiated sound total attenuation values based on AHRI Standard 885-2008.

	Octave Band					
	2	3	4	5	6	7
Environmental Effect	2	1	0	0	0	0
Ceiling/Space Effect	16	18	20	26	31	36
Total Attenuation Deduction	18	19	20	26	31	36

The ceiling/space effect assumes the following conditions:

1. 5/8" (16) tile, 20 lb/ft³ (320 kg/m³) density.
2. The plenum is at least 3 feet (914) deep.
3. The plenum space is either wide (over 30 feet [9 m]) or lined with insulation.
4. The ceiling has no significant penetration directly under the unit.

Discharge Sound

Table E1 of Appendix E provides typical discharge sound attenuation values for three sizes of terminal unit.

1. Small box; Less than 300 cfm (142 l/s)
(Discharge Duct 8" x 8" [203 x 203]).
2. Medium box; 300 – 700 cfm (142 - 330 l/s)
(Discharge Duct 12" x 12" [305 x 305]).
3. Large box; Greater than 700 cfm (330 l/s)
(Discharge Duct 15" x 15" [381 x 381]).

These attenuation values have been used to tabulate Discharge NC levels applied against the terminal airflow volume and not terminal unit size.

The following tables provide the calculation method for the discharge sound total attenuation values based on AHRI Standard 885-2008.

Small Box < 300 cfm	Octave Band					
	2	3	4	5	6	7
Environmental Effect	2	1	0	0	0	0
5 ft. (1.5 m) 1" (25) Duct Lining	2	6	12	25	29	18
Branch Power Division (1 outlet)	0	0	0	0	0	0
5 ft. (1.5 m), 8 in. dia. (200) Flex Duct	5	10	18	19	21	12
End Reflection	10	5	2	1	0	0
Space Effect	5	6	7	8	9	10
Total Attenuation Deduction	24	28	39	53	59	40

Medium Box 300 – 700 cfm	Octave Band					
	2	3	4	5	6	7
Environmental Effect	2	1	0	0	0	0
5 ft. (1.5 m) 1" (25) Duct Lining	2	4	10	20	20	14
Branch Power Division (2 outlets)	3	3	3	3	3	3
5 ft. (1.5 m), 8 in. dia. (200) Flex Duct	5	10	18	19	21	12
End Reflection	10	5	2	1	0	0
Space Effect	5	6	7	8	9	10
Total Attenuation Deduction	27	29	40	51	53	39

Large Box >700 cfm	Octave Band					
	2	3	4	5	6	7
Environmental Effect	2	1	0	0	0	0
5 ft. (1.5 m) 1" (25) Duct Lining	2	3	9	18	17	12
Branch Power Division (3 outlets)	5	5	5	5	5	5
5 ft. (1.5 m), 8 in. dia. (200) Flex Duct	5	10	18	19	21	12
End Reflection	10	5	2	1	0	0
Space Effect	5	6	7	8	9	10
Total Attenuation Deduction	29	30	41	51	52	39

1. Flexible duct is non-metallic with 1" (25) insulation.
2. Space effect (room size and receiver location) 2500 ft.³ (69 m³) and 5 ft. (1.5 m) distance from source.

For a complete explanation of the attenuation factors and the procedures for calculating room NC levels, please refer to the acoustical engineering guidelines in the Nailor VAV Terminal Units Catalog and AHRI Standard 885-2008.

Performance Data • NC Level Application Guide

Model Series 30HQ • Hospital Grade • Dissipative Silencer

Unit Size	Airflow		Min. inlet ΔPs		NC Levels @ Inlet Pressure (ΔPs) shown											
					DISCHARGE					RADIATED						
					Min. ΔPs	0.5" w.g. 125 Pa	1.0" w.g. 250 Pa	1.5" w.g. 375 Pa	2.0" w.g. 500 Pa	3.0" w.g. 750 Pa	Min. ΔPs	0.5" w.g. 125 Pa	1.0" w.g. 250 Pa	1.5" w.g. 375 Pa	2.0" w.g. 500 Pa	3.0" w.g. 750 Pa
4	200	94	0.33	82	-	-	-	-	-	-	-	-	-	21	24	28
	150	71	0.18	45	-	-	-	-	-	-	-	-	-	21	22	22
	100	47	0.08	20	-	-	-	-	-	-	-	-	-	20	23	23
	75	35	0.04	10	-	-	-	-	-	-	-	-	-	-	20	20
	50	24	0.02	5	-	-	-	-	-	-	-	-	-	-	-	-
5	300	142	0.13	32	-	-	-	-	-	-	-	-	-	21	23	28
	250	118	0.09	22	-	-	-	-	-	-	-	-	-	22	25	25
	200	94	0.06	15	-	-	-	-	-	-	-	-	-	20	22	22
	125	59	0.03	7	-	-	-	-	-	-	-	-	-	-	-	-
	100	47	0.02	5	-	-	-	-	-	-	-	-	-	-	-	-
6	450	212	0.27	67	-	-	-	-	-	20	-	-	-	22	24	29
	400	189	0.22	55	-	-	-	-	-	-	-	-	-	21	25	29
	300	142	0.14	35	-	-	-	-	-	-	-	-	-	20	21	25
	200	94	0.07	17	-	-	-	-	-	-	-	-	-	-	-	20
	100	47	0.02	5	-	-	-	-	-	-	-	-	-	-	-	-
7	650	307	0.10	25	-	-	-	-	21	25	-	-	21	24	29	34
	550	260	0.07	17	-	-	-	-	21	25	-	-	-	24	28	32
	335	158	0.03	7	-	-	-	-	-	-	-	-	20	20	22	24
	225	106	0.02	4	-	-	-	-	-	-	-	-	-	-	-	-
	110	52	0.01	2	-	-	-	-	-	-	-	-	-	-	-	-
8	800	378	0.07	17	-	-	-	-	-	23	-	-	22	24	28	30
	700	330	0.06	15	-	-	-	-	-	23	-	-	21	24	26	31
	600	283	0.04	10	-	-	-	-	-	21	-	-	-	23	25	31
	400	189	0.02	5	-	-	-	-	-	-	-	-	-	20	21	25
	175	83	0.01	2	-	-	-	-	-	-	-	-	-	-	-	-
9	1050	496	0.08	20	-	-	-	20	23	26	-	20	21	24	28	33
	900	425	0.06	15	-	-	-	-	21	25	-	-	-	23	28	32
	675	319	0.04	10	-	-	-	-	20	21	-	-	-	22	25	26
	450	212	0.02	5	-	-	-	-	-	-	-	-	-	-	20	22
	225	106	0.01	2	-	-	-	-	-	-	-	-	-	-	-	-
10	1350	637	0.15	37	-	-	-	-	21	26	-	20	24	28	29	32
	1100	519	0.10	25	-	-	-	-	20	24	-	-	21	24	25	31
	825	389	0.06	15	-	-	-	-	-	20	-	-	-	21	23	28
	550	260	0.03	7	-	-	-	-	-	-	-	-	-	-	-	22
	275	130	0.01	2	-	-	-	-	-	-	-	-	-	-	-	-
12	2000	944	0.19	47	-	21	23	24	26	28	23	25	29	31	33	37
	1600	755	0.12	30	-	-	-	21	21	25	-	20	25	28	30	35
	1200	566	0.07	17	-	-	-	-	-	-	-	-	20	24	28	31
	800	378	0.03	7	-	-	-	-	-	-	-	-	-	20	21	24
	400	189	0.01	2	-	-	-	-	-	-	-	-	-	-	-	-
14	2700	1274	0.26	65	-	23	25	29	30	31	24	26	30	34	37	40
	2100	991	0.15	37	-	-	22	26	25	27	-	21	26	31	34	37
	1550	731	0.08	20	-	-	-	-	-	21	-	-	24	28	30	34
	1050	496	0.03	7	-	-	-	-	-	-	-	-	-	24	28	28
	525	248	0.01	2	-	-	-	-	-	-	-	-	-	-	-	-
16	3500	1652	0.43	107	-	21	25	29	30	33	28	30	33	36	39	43
	2800	1321	0.28	70	-	-	20	24	26	28	23	24	29	34	36	40
	2100	991	0.16	40	-	-	22	25	24	23	-	-	26	30	34	36
	1400	661	0.07	17	-	-	-	-	-	20	-	-	21	26	29	31
	700	330	0.02	5	-	-	-	-	-	-	-	-	-	-	23	21
24 x 16	8000	3775	0.40	99	20	28	29	29	33	35	41	44	48	51	54	57
	7000	3303	0.31	77	-	26	27	28	31	34	40	41	47	49	51	55
	6000	2831	0.23	57	-	24	28	29	31	33	36	39	45	47	49	53
	5000	2360	0.16	40	-	21	24	26	28	30	31	37	43	45	47	50
	4000	1888	0.10	25	-	-	22	24	27	28	24	35	39	43	45	47
3000	1416	0.06	15	-	-	21	23	26	27	20	31	36	38	40	44	

For performance table notes, see page 7.

Performance Data • Discharge Sound Power Levels Model Series 30HQ • Hospital Grade • Dissipative Silencer



Unit Size	Airflow cfm / l/s	Min. inlet ΔPs "w.g. Pa	Sound Power Octave Bands @ Inlet Pressure ΔPs shown																																												
			Minimum ΔPs							0.5" w.g. (125Pa)ΔPs							1.0" w.g. (250Pa)ΔPs							1.5" w.g. (375Pa)ΔPs							2.0" w.g. (500Pa)ΔPs							3.0" w.g. (750Pa)ΔPs									
			2	3	4	5	6	7	2	3	4	5	6	7	2	3	4	5	6	7	2	3	4	5	6	7	2	3	4	5	6	7	2	3	4	5	6	7									
4	200 94	.33 82	- 38 40 29 48 24	45 50 47 35 49 24	49 44 53 40 22 30	49 56 53 42 25 35	50 57 56 44 27 37	49 57 58 48 33 40	150 71	.18 45	- 41 36 23 39 35	45 46 46 32 44 21	48 50 48 36 50 29	47 52 51 39 22 33	46 53 54 43 24 35	45 52 56 49 31 41	100 47	.08 20	- - 37 37 27 -	47 47 47 29 41 35	49 45 46 34 47 27	49 46 50 41 53 31	48 45 51 44 26 35	36 42 49 44 32 42	75 35	.04 10	- - 31 28 - -	- 45 45 25 37 31	- 41 46 36 49 26	- 37 45 38 56 30	- 37 46 40 28 36	- 39 46 42 31 41	50 24	.02 5	- - - - - -	- 43 39 28 40 31	- 35 43 35 55 27	- 32 45 37 60 33	- 40 44 34 60 36	- 40 42 34 58 38							
	300 142	.13 32	48 51 43 35 27 28	45 52 51 41 29 30	36 55 53 43 31 33	49 56 56 46 34 37	51 60 57 47 36 40	51 61 59 48 37 43	250 118	.09 22	- 39 38 29 42 40	43 49 47 37 22 24	46 53 50 40 27 32	53 56 52 43 28 35	53 56 53 43 30 37	48 57 56 47 32 41	200 94	.06 15	- 41 43 24 34 32	40 45 43 32 42 37	43 49 46 36 47 28	44 52 49 39 21 33	45 53 51 42 24 36	46 54 54 38 29 41	125 59	.03 7	- - 32 30 - -	- 40 37 26 36 31	49 45 43 32 43 24	49 46 48 41 51 31	37 46 49 47 27 37	36 43 49 48 37 46	100 47	.02 5	- - 29 25 - -	- 39 35 23 33 30	- 43 44 36 46 25	- 43 47 45 25 34	- 42 47 47 32 39	- 39 46 45 38 46							
	450 212	.27 67	51 41 38 38 35 31	50 50 47 42 40 36	57 53 51 44 49 37	59 56 54 46 41 40	63 60 59 52 46 44	65 62 60 52 51 44	400 189	.22 55	49 38 35 34 30 25	51 49 46 40 36 32	55 53 50 42 45 34	63 57 53 45 38 37	64 58 55 47 39 39	63 61 57 48 40 42	300 142	.14 35	- 31 29 27 35 31	49 46 42 33 24 20	52 49 46 37 27 27	56 52 47 39 29 32	56 54 50 40 30 34	58 57 54 43 31 38	200 94	.07 17	- - 18 32 - -	44 41 35 26 38 34	49 45 40 30 45 23	50 48 43 33 49 29	50 49 46 35 23 32	51 51 50 41 24 38	100 47	.02 5	- - - - - -	- 38 28 39 33 31	- 41 39 26 55 26	- 43 43 31 53 30	- 43 46 37 58 32	- 43 46 42 28 38							
	650 307	.10 25	46 50 51 47 31 37	51 55 53 48 34 41	54 56 55 45 34 44	59 60 58 48 34 47	62 63 61 51 35 48	64 66 62 51 34 50	550 260	.07 17	45 47 45 42 24 31	49 52 49 39 28 37	53 55 53 43 27 40	62 61 56 46 30 44	63 63 59 48 31 47	65 66 63 51 34 50	335 158	.03 7	47 34 31 26 29 22	46 46 43 33 45 29	51 52 48 37 53 35	53 56 51 40 23 40	54 58 55 41 24 43	57 61 59 47 29 47	225 106	.02 4	- - 30 26 - -	43 42 40 30 41 25	47 50 45 32 49 32	48 52 49 36 52 37	51 53 51 40 55 41	53 57 53 43 25 46	110 52	.01 2	- - - - - -	- 38 34 22 34 21	- 44 39 26 45 29	- 45 45 31 49 31	- 46 41 31 51 35	- 49 49 36 24 45							
	800 378	.07 17	48 49 45 43 34 32	57 58 52 44 40 42	59 59 53 46 41 47	61 61 54 46 40 47	62 61 56 48 39 48	65 65 59 50 40 51	700 330	.06 15	46 47 43 40 30 27	54 55 49 41 35 39	56 56 51 43 36 44	62 60 53 45 36 45	62 60 55 46 36 47	66 64 58 48 37 49	600 283	.04 10	42 45 37 34 21 18	52 53 47 40 32 40	56 55 49 41 32 41	58 58 51 43 31 42	60 60 54 44 32 44	62 63 57 47 33 48	400 189	.02 5	- 33 28 22 29 -	44 46 40 30 42 29	50 50 43 33 20 33	55 55 46 37 23 38	56 56 49 39 24 40	57 59 53 43 28 44	175 83	.01 2	- - - - - -	- 36 29 17 37 19	- 44 37 25 44 27	45 47 43 31 49 32	45 47 45 42 20 38	45 45 46 36 24 44							
1050 496	.08 20	43 44 43 40 35 35	53 58 52 46 45 44	57 60 55 47 46 49	60 63 57 49 47 51	62 65 59 50 48 53	66 68 63 53 49 57	900 425	.06 15	39 41 36 34 26 25	51 55 48 41 39 39	56 58 52 45 42 45	60 61 54 46 43 48	66 64 57 47 44 50	64 67 60 49 45 54	675 319	.04 10	- 33 29 24 39 30	49 51 43 37 31 33	54 56 48 40 35 40	58 60 51 41 37 46	59 62 54 43 38 47	58 63 56 45 40 51	450 212	.02 5	- - 15 30 - -	- 46 36 28 24 30	48 52 45 32 26 36	51 53 46 35 27 41	52 54 49 36 32 43	51 55 52 42 36 49	225 106	.01 2	- - - - - -	- 35 25 14 38 18	43 45 39 26 22 33	44 46 43 30 27 37	48 45 43 33 30 41	43 44 45 36 33 46								
1350 637	.15 37	44 46 47 45 47 46	55 57 52 48 51 51	58 60 56 49 52 53	60 62 58 50 53 55	68 63 60 52 53 57	64 68 62 54 55 59	1100 519	.10 25	39 42 41 40 39 37	52 55 48 44 44 42	56 58 52 45 46 47	60 60 54 48 48 50	62 63 56 49 49 53	63 66 59 51 50 55	825 389	.06 15	- 37 36 33 27 24	49 51 43 37 36 33	55 54 48 41 39 42	58 59 51 43 41 45	59 61 53 44 42 47	62 63 57 47 45 51	550 260	.03 7	- - 24 17 - -	46 44 37 28 24 28	50 51 42 34 29 36	53 54 46 36 33 42	54 54 49 38 35 43	54 55 53 42 37 48	275 130	.01 2	- - - - - -	- 37 29 18 38 20	41 42 37 26 35 31	43 43 39 28 31 38	43 42 40 31 33 44	45 42 42 34 36 49								
2000 944	.19 47	51 50 49 44 48 49	59 59 52 49 54 57	60 62 56 52 57 59	63 63 59 53 57 60	64 65 60 55 58 62	68 69 63 58 60 65	1600 755	.12 30	38 35 39 39 40 36	51 53 48 45 50 49	56 57 52 47 51 52	62 62 57 52 55 57	62 63 56 52 55 57	65 67 61 54 57 61	1200 566	.07 17	32 31 34 33 27 25	45 46 39 37 37 36	53 52 45 40 41 43	56 56 48 42 44 47	57 59 50 44 46 50	60 61 55 47 51 53	800 378	.03 7	44 27 28 20 28 -	47 46 39 35 35 33	54 52 43 38 39 41	56 55 47 41 43 46	57 56 50 43 46 47	57 58 53 47 50 52	400 189	.01 2	- - - 25 - -	47 41 33 26 24 26	52 48 42 35 33 35	46 45 41 35 39 41	45 44 41 38 43 46	45 42 42 39 47 54								
2700 1274	.26 65	53 50 53 53 54 52	51 58 56 56 59 59	65 62 60 57 60 61	68 64 62 58 66 66	70 64 63 60 62 67	72 69 66 64 63 68	2100 991	.15 37	53 49 47 46 47 44	58 54 51 50 52 50	63 58 55 52 54 58	67 61 58 54 56 62	67 63 59 56 56 61	69 66 63 58 58 63	1550 731	.08 20	47 37 39 39 36 31	54 47 43 42 43 41	59 53 49 46 47 51	62 57 53 50 50 54	63 59 56 51 51 54	64 61 60 55 54 57	1050 496	.03 7	- 28 27 23 27 -	49 42 39 35 35 34	55 49 44 42 41 44	55 51 49 44 43 46	57 53 51 46 45 48	57 55 55 51 49 52	525 248	.01 2	- - - - - -	44 36 32 28 25 28	46 41 39 34 33 36	47 39 42 38 39 42	45 40 43 41 42 47	47 40 45 43 46 51								
3500 1652	.43 107	53 50 50 48 51 52	58 56 55 56 56 57	67 63 61 59 60 61	70 66 63 61 61 66	70 69 65 61 63 67	73 71 67 64 65 70	2800 1321	.28 70	49 45 41 44 46 45	58 54 53 53 54 53	62 60 57 54 56 56	65 63 60 56 58 60	68 65 62 57 60 62	71 69 65 60 62 65	2100 991	.16 40	48 44 44 43 45 45	58 53 53 51 51 52	65 59 57 54 56 58	67 64 60 56 58 61	69 66 62 57 55 58	69 69 65 60 61 61	1400 661	.07 17	- 26 29 23 17 -	48 50 42 39 38 40	55 51 46 43 44 45	57 54 51 46 46 47	58 56 53 49 50 50	61 58 58 52 54 56	700 330	.02 5	- - 25 23 - -	50 37 34 30 27 31	45 43 41 36 37 40	47 45 45 40 43 47	49 46 47 43 47 50	53 48 51 47 50 54								
8000 3775	.40 99	69 62 59 54 56 54	75 67 65 59 63 63	73 68 69 68 70 66	76 68 69 68 71 66	79 72 72 71 73 70	81 74 74 74 76 72	7000 3303	.31 77	65 56 56 51 51 49	74 67 63 58 61 60	73 68 68 68 68 64	74 69 69 68 69 64	78 72 72 70 71 67	80 74 74 74 74 70	6000 2831	.23 57	63 55 53 49 48 45	72 65 63 58 60 59	74 69 67 63 65 63	74 70 67 65 67 66	75 72 70 68 70 68	76 73 73 71 72 70	5000 2360	.16 40	59 46 45 38 34 39	69 93 61 57 56 57	70 65 64 61 62 60	69 66 65 62 63 62	71 68 67 65 66 65	72 69 68 68 68 67	4000 1888	.10 25	56 47 45 39 41 38	66 61 59 55 54 55	68 64 63 59 61 58	67 65 65 60 62 60	69 66 66 63 65 63	70 67 67 66 66 65	3000 1416	.06 15	54 45 44 39 40 37	63 60 57 53 53 54	64 62 62 59 60 57	65 63 63 61 62 59	67 64 65 64 64 62	68 66 66 65 65 63

For performance table notes, see page 7.

SINGLE DUCT TERMINAL UNITS



Performance Data • Radiated Sound Power Levels Model Series 30HQ • Hospital Grade • Dissipative Silencer



Inlet Size	Airflow cfm l/s	Min. inlet ΔPs "w.g. Pa		Sound Power Octave Bands @ Inlet Pressure ΔPs shown																																							
				Minimum ΔPs							0.5" w.g. (125Pa) ΔPs							1.0" w.g. (250Pa) ΔPs							1.5" w.g. (375Pa) ΔPs							2.0" w.g. (500Pa) ΔPs							3.0" w.g. (750Pa) ΔPs				
		2	3	4	5	6	7	2	3	4	5	6	7	2	3	4	5	6	7	2	3	4	5	6	7	2	3	4	5	6	7	2	3	4	5	6	7						
4	200 94	.33	82	-	36	33	32	-	-	-	39	37	38	29	29	49	46	43	37	30	29	53	52	47	40	32	31	53	53	50	42	33	33	54	55	53	47	37	37				
	150 71	.18	45	-	35	29	31	-	-	-	40	36	30	25	23	47	46	40	34	28	26	49	50	47	39	31	30	47	48	48	43	34	32	48	48	48	50	40	37				
	100 47	.08	20	-	-	-	-	-	-	-	37	32	27	-	-	-	43	42	34	27	23	-	44	45	41	32	29	-	43	46	46	36	32	-	42	44	51	43	38				
	75 35	.04	10	-	-	-	-	-	-	-	37	31	26	-	-	-	41	43	37	29	24	-	42	45	42	32	29	49	38	42	45	40	33	-	36	41	48	44	40				
	50 24	.02	5	-	-	-	-	-	-	-	37	38	30	-	-	-	36	41	40	32	27	-	35	40	43	38	31	-	34	38	40	38	33	-	32	36	37	35	37				
5	300 142	.13	32	47	38	32	32	30	27	50	43	37	37	35	31	54	46	44	37	35	31	57	49	47	39	38	33	59	52	49	40	39	35	59	55	53	43	43	39				
	250 118	.09	22	-	35	31	25	23	-	50	39	36	29	28	25	54	45	42	33	32	28	55	48	45	35	35	30	56	51	48	37	37	32	57	53	51	42	41	35				
	200 94	.06	15	-	-	-	-	-	-	50	38	34	27	26	-	52	43	39	30	30	25	52	45	43	32	32	28	53	48	46	36	36	30	53	48	48	44	41	34				
	125 59	.03	7	-	-	-	-	-	-	-	43	29	21	-	-	48	40	38	28	27	-	48	42	42	34	33	27	49	42	44	39	38	29	49	42	44	47	46	37				
	100 47	.02	5	-	-	-	-	-	-	-	33	29	-	-	-	-	39	38	28	26	-	-	40	42	36	34	26	46	40	43	43	41	31	47	41	43	47	46	37				
6	450 212	.27	67	48	44	37	35	30	28	48	47	40	38	32	29	56	50	45	40	34	31	59	53	48	44	36	33	61	55	50	43	39	37	64	58	54	46	42	41				
	400 189	.22	55	-	42	33	33	28	26	49	46	39	35	30	28	56	49	44	38	32	29	59	52	47	40	36	33	62	54	49	42	39	36	65	58	54	45	42	41				
	300 142	.14	35	-	34	27	26	-	-	47	42	35	29	25	-	55	46	40	33	30	28	58	49	44	36	33	32	59	51	47	38	36	34	60	55	51	43	39	39				
	200 94	.07	17	-	-	-	-	-	-	47	36	30	24	-	-	53	43	38	30	29	28	53	45	43	32	31	30	53	47	44	36	32	32	55	49	46	43	37	37				
	100 47	.02	5	-	-	-	-	-	-	-	34	27	-	-	-	-	35	38	33	29	24	45	39	40	37	31	28	47	39	40	42	37	32	46	40	40	46	44	38				
7	650 307	.10	25	48	45	46	38	31	30	49	48	45	37	31	29	54	50	47	40	34	32	60	54	50	44	37	35	64	58	54	48	40	38	67	63	58	51	44	43				
	550 260	.07	17	49	43	41	33	27	25	48	44	40	32	28	26	55	49	45	38	32	30	61	54	49	43	36	33	64	58	52	45	38	36	65	61	57	50	42	40				
	335 158	.03	1	-	-	28	33	-	-	-	40	35	29	24	-	58	48	42	36	30	28	57	51	46	40	32	30	57	52	48	42	34	32	57	53	50	47	39	38				
	225 106	.02	4	-	-	-	-	-	-	-	39	33	28	-	-	50	45	40	34	28	25	52	47	43	38	31	29	51	47	43	41	33	31	52	48	45	42	35	36				
	110 52	.01	2	-	-	-	-	-	-	-	28	25	-	-	-	-	37	33	32	27	24	-	36	32	31	27	26	-	38	35	34	29	29	-	38	35	35	32	36				
8	800 378	.07	17	51	46	40	33	31	28	55	48	44	35	33	29	57	51	48	38	36	32	61	54	50	41	40	35	64	56	53	43	43	38	66	58	55	46	47	41				
	700 330	.06	15	50	43	37	31	29	25	51	47	42	33	31	28	57	51	47	37	36	32	61	53	50	40	39	35	63	55	51	42	41	37	64	59	56	45	44	40				
	600 283	.04	10	-	39	33	29	26	-	50	45	40	31	30	26	57	49	45	35	34	31	60	53	49	38	38	33	61	55	51	40	40	36	63	59	56	46	43	40				
	400 189	.02	5	-	35	26	-	-	-	49	41	36	28	27	24	54	47	41	32	31	30	57	52	46	35	34	32	57	52	47	37	36	34	59	54	51	41	40	39				
	175 83	.01	2	-	-	-	-	-	-	-	36	31	23	23	-	48	41	35	29	29	27	48	42	37	31	31	30	49	42	39	33	33	33	49	42	40	35	37	38				
9	1050 496	.08	20	50	44	44	41	34	32	51	46	46	41	36	33	55	51	47	41	36	34	59	54	50	45	39	37	62	58	53	48	42	40	66	62	51	52	46	44				
	900 425	.06	15	48	40	39	36	30	29	50	45	42	37	32	30	56	50	45	40	35	33	60	54	49	44	39	36	63	58	52	47	41	38	61	61	57	50	44	42				
	675 319	.04	10	47	37	31	29	22	-	49	41	36	31	28	25	55	48	42	37	32	30	58	54	46	41	35	33	60	56	50	44	38	36	60	57	52	47	41	39				
	450 212	.02	5	-	-	24	-	-	-	48	40	33	30	26	24	53	46	39	34	30	29	54	49	43	38	33	31	55	50	46	41	35	34	56	52	48	45	39	38				
	225 106	.01	2	-	-	-	-	-	-	-	37	31	26	-	-	-	40	34	31	28	26	-	41	36	34	30	30	-	41	37	35	32	33	48	42	39	38	35	38				
10	1350 637	.15	37	53	42	41	36	30	23	55	47	46	39	34	29	58	53	50	44	38	34	60	56	53	48	42	37	63	57	54	50	46	41	65	61	57	54	48	45				
	1100 519	.10	25	51	37	35	30	25	-	53	46	42	35	31	27	55	50	47	41	35	31	60	54	50	45	39	36	61	66	51	47	42	39	64	61	55	51	45	43				
	825 389	.06	15	-	33	29	25	-	-	50	43	38	32	29	25	55	48	43	38	33	30	58	52	47	42	37	34	59	54	49	44	38	36	61	57	53	49	43	40				
	550 260	.03	7	-	-	-	-	-	-	-	38	33	29	25	-	51	44	38	34	30	28	53	47	42	38	32	34	56	50	45	41	36	33	57	52	48	45	39	37				
	275 130	.01	2	-	-	-	-	-	-	-	35	29	26	-	-	-	39	33	31	28	-	-	40	36	34	31	29	-	40	36	36	33	32	48	43	40	40	36	36				
12	2000 944	.19	47	54	50	49	44	37	33	58	55	51	46	39	35	61	59	53	49	43	37	64	61	56	52	45	41	65	62	58	55	48	44	68	66	61	58	51	49				
	1600 755	.12	30	52	45	41	36	30	27	56	52	45	40	34	30	59	56	49	46	38	35	61	58	53	49	42	39	62	60	55	51	44	42	65	64	58	55	48	46				
	1200 566	.07	17	47	39	33	29	24	-	52	48	40	36	30	27	55	52	45	41	34	32	58	55	49	45	38	36	60	58	51	48	41	39	61	61	55	52	45	44				
	800 378	.03	7	-	-	-	-	-	-	50	41	34	30	26	-	52	48	41	37	31	30	53	52	45	42	35	33	54	53	47	44	37	36	56	55	50	48	42	42				
	400 189	.01	2	-	-	-	-	-	-	-	37	31	28	-	-	-	42	36	33	29	28	47	45	40	37	32	31	48	47	42	40	35	34	47	44	40	43	40	42				
14	2700 1274	.26	65	57	54	50	46	42	36	59	57	52	48	44	38	61	60	54	49	46	38	64	63	56	51	49	45	65	66	59	53	50	48	69	69	63	57	53	51				
	2100 9																																										

Performance Data • AHRI Certification and Performance Notes

Model Series 30HQ • Hospital Grade • AHRI Certification Rating Points

Unit Size	Airflow		Min. inlet ΔPs		Discharge Sound Power Levels @ 1.5" w.g. (375 Pa) ΔPs Octave Band							Radiated Sound Power Levels @ 1.5" w.g. (375 Pa) ΔPs Octave Band						
	cfm	l/s	"w.g. Pa		2	3	4	5	6	7	2	3	4	5	6	7		
4	150	71	.18	45	47	52	51	39	22	33	49	50	47	39	31	30		
5	250	118	.09	22	53	56	52	43	28	35	55	48	45	35	35	30		
6	400	189	.22	55	63	57	53	45	38	37	59	52	47	40	36	33		
7	550	260	.07	17	62	61	56	46	30	44	61	54	49	43	36	33		
8	700	330	.06	15	62	60	53	45	36	45	61	53	50	40	39	35		
9	900	425	.06	15	60	61	54	46	43	48	60	54	49	44	39	36		
10	1100	519	.10	25	60	60	54	48	48	50	60	54	50	45	39	36		
12	1600	755	.12	30	62	62	57	52	55	57	61	58	53	49	42	39		
14	2100	991	.15	37	67	61	58	54	56	62	63	61	55	48	44	43		
16	2800	1321	.28	70	65	63	60	56	58	60	65	63	57	50	44	39		
24 x 16	5350	2525	.18	45	72	68	66	64	65	64	72	70	70	65	60	55		

Performance Notes for Sound Power Levels:

1. Discharge sound power is the noise emitted from the unit discharge into the downstream duct.
2. Radiated sound power is the breakout noise transmitted through the unit casing walls.
3. Sound power levels are in decibels, dB re 10⁻¹² watts.
4. All sound data listed by octave bands is raw data without any corrections for room absorption or duct attenuation. Dash (-) in space indicates sound power level is less than 20 dB or equal to background.
5. Minimum inlet ΔPs is the minimum operating pressure requirement of the unit (damper full open) and the difference in static pressure from inlet to discharge of the unit.
6. Data derived from independent tests conducted in accordance with ANSI/ASHRAE Standard 130-2008 and AHRI Standard 880-2008.



Ratings are certified in accordance with AHRI Standards.

Suggested Specifications

Model Series 30HQ Hospital Grade Section 15840

1.01 Furnish and install **Nailor Model 30HQ Single Duct Variable Volume Hospital Grade Terminal Units** of the sizes and capabilities as indicated on the drawings. Units shall be pressure independent with (pneumatic, analog electronic, DDC) controls. Units shall reset to any flow between minimum and the maximum cataloged airflow as allowed by the specific controller.

1.02 The entire hospital grade terminal unit shall be designed and built as a single unit. The unit shall be provided with a primary variable air volume damper that controls the air quantity in response to a (pneumatic, electric, analog electronic, or DDC) thermostat. The unit shall include a factory installed dissipative silencer and include all options such as electric or hot water heating coils and access doors. The space limitations shall be reviewed carefully to insure that all units will fit into the space allowed.

1.03 Unit casing shall be 22 gauge (0.86) galvanized steel with round or flat oval inlets with 5 1/2" (140 mm) deep inlet duct collar for field connection. Outlets shall be rectangular and configured for slip and drive connections. Casing leakage downstream of the damper shall not exceed 1% @ 1" w.g. (250 Pa). High side casing leakage shall not exceed 2% @ 3" w.g. (750 Pa).

1.04 Damper assemblies of 16 gauge (1.63) galvanized steel shall be multiple opposed blade construction arranged to close at 45 degrees from full open to minimize air turbulence and provide near linear operation. Damper blades shall be fitted with flexible seals for tight closure and minimized sound generation. Damper blades shall be screwed through the shaft to insure that no slippage occurs. Blade shafts shall pivot on corrosion free Celcor® bearings. In the fully closed position, air leakage past the closed damper shall not exceed 2% of the nominal catalog rating at 3" w.g. (750 Pa) inlet static pressure as rated by ASHRAE Standard 130.

1.05 The terminal units shall be capable of operation as described herein with a minimum inlet static pressure of 0.28" w.g. (70 Pa) @2000 fpm (10.2 m/s) inlet velocity. (The sequence of operations should be described here, if not part of the temperature controls specifications.) Each unit shall be complete with factory mounted (pneumatic, electric, analog electronic, or DDC) controls. Gauge tap ports shall be supplied in the piping between the flow pick up and the controller.

1.06 Each unit shall be constructed with single point electrical (and pneumatic) connections. All electrical components shall be ETL or UL listed or recognized and installed in accordance with the National Electrical Code. All electrical components shall be installed in a control box. The entire assembly shall be ETL listed and so labeled.

1.07 Each VAV section shall be internally lined with 13/16" (21) thick, 4 lb. density fiberglass insulation with a reinforced aluminum FSK facing. Units shall meet NFPA 90A and UL 181 standards.

1.08 All sound data shall be compiled in an independent laboratory and in accordance with the latest version of AHRI Standard 880 and ANSI/ASHRAE Standard 130. All units shall be AHRI certified and bear the AHRI certification label.

1.09 Dissipative silencer sections shall contain a unit casing constructed of 22 ga. (.86) galvanized steel. Inlet and discharge shall be rectangular and configured for slip and drive connections. Each silencer shall be internally lined with 13/16" (21) thick, 4 lb. density fiberglass insulation with a reinforced aluminum FSK facing, placed inside the top and bottom sides of the silencer, thereby eliminating the requirement for field wrapping with thermal insulation. The silencer baffles shall be filled with fiberglass

acoustical absorption media and encapsulated by 22 ga. (.86) perforated coated steel baffles. A mylar liner shall separate the fiberglass from the perforated metal baffle, with an acoustical spacer and isolate the fiberglass from the airstream. The perforated metal baffles shall be rigidly fastened to the casing of the silencer. Units shall meet NFPA 90A and UL 181 standards.

30HQE

Electric Heat Insert following paragraphs after 30HQ specifications

1.10 Single Duct VAV Hospital Grade Terminal Unit Electric Heating Coils:

a. Electric heating coils shall consist of open coils of high grade nickel and chromium resistance wire or nichrome elements and insulated with ceramic insulators in galvanized steel brackets, supported in heavy gauge galvanized steel frames. Each unit employing an electric heating coil shall be constructed and installed in accordance with the requirements of the local authorities and shall be UL or ETL listed specifically with the heater as a component of the terminal unit device.

b. Coils shall have the capacities indicated in Contract Documents. Coils rated up through 5 kW shall be single phase, 277 volt, 60 hertz and coils larger than 5 kW shall be three phase, four wire, 480Y/277 volt, 60 hertz. Electric heating coils up to and including 4 kW shall be single stage. Electric coils above 4 kW shall be two stage.

c. Terminal bolts, nuts and washers shall be of corrosion resistant materials. Coils shall be constructed so the installation may be accomplished in accordance with the provisions of the National Electrical Code, for zero clearance. Coils shall be given a 2000 volt dielectric test at the factory.

d. Automatic reset thermal cutouts shall be furnished for primary protection with manually resettable limit switches in power circuits for secondary protection. Both devices shall be serviceable through terminal box without removing heating element from the terminal device. The air pressure safety cutout pickup probe shall be remotely mounted near the volume control damper for maximum fidelity.

e. Heating coils shall have a terminal box and cover, with quiet type built-in magnetic step controlled contactors for each circuit, branch circuit fusing for each branch circuit on heaters over 48 amps per the NEC, and an air flow safety interlock switch for installation in the heater control enclosure. Contactors mounted in terminal units that are located above the ceiling in tenant occupied spaces shall be mercury step type. Provide a 120 or 24 volt control power transformer with an integral or separately mounted primary and/or secondary overcurrent protection device in accordance with NEC requirements.

f. All wiring of built-in devices shall be brought to clearly marked terminal strips. A complete wiring diagram shall be permanently attached to the heating coil panel cover.

g. Electric heating coils shall be designed for operation with the DDC controller and control system.

h. Electric heating coils and the associated control panels shall be constructed as a component of the entire terminal unit and mounted in the discharge attenuator downstream of the terminal unit. The resulting unit, including the heater and the VAV damper shall be no longer than 31 1/2" in length.

i. The manufacturer shall prove adequate even airflow over the electric heating coil under the full range of airflow scheduled (minimum to maximum) to prevent uneven heating of the electric coils. The terminal device shall be listed in accordance with UL 1995 and UL 1996 as a composite assembly consisting of the VAV terminal device and the electric heating device.

Suggested Specifications (continued)

j. Shop Drawings shall be submitted for review. Drawings shall indicate specifically the exact construction, materials, internal wiring, NEC working clearances, etc., of the terminal units and electric heating coils to be furnished under these Specifications.

30HQW

Hot Water Heating Coil

Insert following paragraphs after 30HQ specifications

1.10 Single Duct VAV Hospital Grade Terminal Device Hot Water Heating Coils

a. Terminal unit hot water heating coils shall be mounted on the discharge of the unit with slip and drive connections. Provide an access door or panel on the bottom of the attenuator section of the terminal unit for servicing and cleaning the unit.

b. Hot water heating coils shall be constructed with copper tubes and aluminum plate fins. Coils shall have a maximum of 10 fins per inch. Supply and return connections shall be on the same end of the coil. Fins shall be bonded to the tubes by means of mechanical expansion of the tubes. Fins shall be at least .0045" thick.

c. Coils shall have galvanized steel casings on all sides no lighter than 22 gauge.

d. Tubes shall be ½" O.D. and shall be spaced approximately 1 ¼" apart, and shall have a minimum wall thickness of 0.016". Hot water shall be equally distributed through all tubes by the use of orifices or header design. Water velocity in the tubes shall not exceed five feet per second. The water pressure drop through the coil shall not exceed 10 feet. Heating coil face velocities shall not exceed the maximum face velocity indicated in the schedules on the Contract Documents.

e. Coils shall be tested by air pressure under water. Coils shall be tested at 300 psig static pressure for 250 psig working pressure or as indicated on the Contract Documents.

f. Coil ratings, calculations, and selection data shall be in accordance with the applicable AHRI Standards and shall be submitted with the Shop Drawings.

Control Specifications (select one)

Pneumatic Controls

(Pressure Independent)

1. The terminal unit manufacturer shall provide factory mounted pressure independent controls which can be reset to modulate airflow between zero and the maximum cataloged capacity. Maximum airflow limits or mechanical volume regulators are not acceptable.

2. Each unit shall be supplied with a **Nailor** Diamond flow sensor with four pick-up points on each side to ensure that controller fidelity shall be within $\pm 5\%$ of set volume under various same size duct inlet conditions and inlet static variation of 0.05" – 6.0" w.g. (12 – 1500 Pa). The sensor shall amplify the sensed velocity pressure and provide a minimum differential pressure of 0.03" w.g. (7.46 Pa) at 500 fpm (2.54 m/s) inlet velocity. Flow measuring taps shall be furnished with each terminal.

3. The reset volume flow controller shall have a constant reset span regardless of the minimum and maximum airflow settings selected. Reset span shall be adjustable from a minimum of 5 psi up to a maximum of 10 psi. Reset start point shall be adjustable

from 3 – 10 psi. Controller air bleed off through the flow sensor is not acceptable. Controller shall be field convertible for direct or reverse acting. The compressed air consumption of the controller shall not exceed 1.0 SCFH at 20 psi. Acceptable controller is Kreuter CSC-3011 or equal.

4. Reset volume controller shall be factory calibrated and set for the scheduled maximum and minimum airflow settings. Flow measuring taps and flow charts shall be supplied with each terminal unit for field balancing and adjustment of airflow. All pneumatic tubing shall be UL listed fire retardant (FR) type. Each terminal shall be supplied with a label showing unit type, size, tag location, minimum and maximum airflow settings and control sequence number. Pneumatic spring return actuators shall be provided and factory mounted by the terminal unit manufacturer.

5. Reset volume controller shall be factory set and calibrated for operation with a direct/reverse (select one) acting room thermostat.

The actuator/damper connection shall be factory mounted to fail to a normally open/closed (select one) position upon loss of control main air pressure.

Analog Electronic Controls (Pressure Independent)

1. The terminal unit manufacturer shall provide factory mounted pressure independent analog electronic controls which can be reset to modulate airflow between zero and the maximum cataloged capacity. Each terminal shall be equipped with a label showing unit type, size, tag location, minimum and maximum airflow settings and control sequence number. Controls shall be factory calibrated and set for the scheduled minimum and maximum flow rates.

2. Each unit shall be supplied with a **Nailor** Diamond flow sensor with four pick-up points on each side to ensure that controller fidelity shall be within $\pm 5\%$ of set volume under various same size duct inlet conditions and inlet static variation of 0.05" – 6.0" w.g. (12 – 1500 Pa). The sensor shall amplify the sensed velocity pressure and provide a minimum differential pressure of 0.03" w.g. (7.46 Pa) at 500 fpm (2.54 m/s) inlet velocity. Flow measuring taps shall be furnished with each terminal. All pneumatic tubing shall be UL listed for fire retardant (FR) type.

3. The velocity controller shall have a constant 2° F (1.11°C) reset span regardless of minimum and maximum airflow limits. It shall include an onboard flow-through transducer utilizing twin platinum resistance temperature detectors and shall be capable of controlling a velocity set point from 0 – 3300 fpm with an accuracy of 3%. The controller shall allow all airflow adjustments to be made from the matching room thermostat. The thermostat shall be furnished by the terminal unit manufacturer and provide a live velocity readout and feature semi-concealed set point slider(s) and set point indicator(s) and thermometer with a fahrenheit (centigrade optional) scale plate.

4. The terminal shall have a 24 VAC combination controller/actuator single assembly. The actuator shall be of a direct drive design and provide a minimum torque of 50 in. lbs. (5.6 Nm). The actuator shall be of the floating reversible type and include a magnetic clutch, adjustable stops and a gear disengagement button. A tri-color LED shall indicate green for opening, red for closing and white for satisfied damper positions. Power consumption of the controller/actuator shall not exceed 4 VA.

5. The terminal manufacturer shall provide a Class 2, 24 VAC control transformer with internal current limiting protection. All controls shall be installed in an approved NEMA 1 enclosure.

Suggested Specifications (continued)

Digital (DDC) Controls (Pressure Independent)

Factory Mounting Procedure

1. The terminals shall be equipped with pressure independent direct digital controls supplied by the control contractor under the automatic temperature controls Division 17 and mounted by the terminal unit manufacturer. The control contractor shall, in addition to sending the controls to the terminal unit manufacturer, provide technical data sheets for all components to be mounted, including dimensional data, mounting hardware and method, as well as application specific wiring and piping diagrams for each terminal type as depicted on the schedules and mechanical drawings.
2. Controls shall be compatible with the pneumatic 'Diamond Flow' multi-point averaging flow sensor supplied by the terminal manufacturer. The sensor shall have four pick-up points on each side to ensure that controller fidelity shall be $\pm 5\%$ of set volume with any typical air turbulence in the duct and any typical flex inlet condition and with an inlet static variation of 0.05" w.g. to 6.0" w.g. (12 – 1500 Pa). The sensor shall amplify the sensed velocity pressure and provide a minimum differential pressure of 0.03" w.g. (7.46 Pa) at 500 fpm (2.54 m/s) inlet velocity. Flow measuring taps and flow curves shall be furnished with each terminal.
3. Controls shall be configured and field calibrated in the field by the control contractor after terminal installation has been completed. Pneumatic tubing shall be UL Listed fire retardant (FR) type. Each terminal shall be supplied with a label showing unit type, size and tag location.
4. The terminal manufacturer shall provide a Class 2, 24 VAC control transformer with internal current limiting protection and disconnect switch. All controls shall be installed in an approved NEMA 1 enclosure supplied and installed by the terminal manufacturer.



"Complete Air Control and Distribution Solutions"

International Group Locations:

**International and United States
Headquarters, Sales, Manufacturing,
Research and Development and Test
Laboratory:**

Nailor Industries of Texas Inc.
4714 Winfield Rd.,
Houston, Texas 77039
U.S.A.
Tel: (281) 590-1172
Fax: (281) 590-3086
info@nailor.com
www.nailor.com

**Canadian Headquarters, Sales and
Manufacturing:**

Nailor Industries Inc.
98 Toryork Drive,
Toronto, Ontario M9L 1X6
Canada
Tel: (416) 744-3300
Fax: (416) 744-3360

**European Sales and Marketing Center,
Manufacturing**

(also responsible for exports to the
Middle East, Asia and Australasia):

Advanced Air (UK) Ltd.
Burrell Way,
Thetford, Norfolk
IP24 3QU
England
Tel: (0)1842 765657
Fax: (0)1842 753493
sales@advancedair.co.uk
www.advancedair.co.uk

**Regional Sales and Manufacturing
Facilities:**

Nailor Industries Inc. (Western U.S.A.)
3200 E. Gowan, Suite 105
N. Las Vegas, NV 89030
Tel: (702) 648-5400
Fax: (702) 638-0400

Nailor Industries (Western) Inc.
Unit F, 4427 - 72nd Avenue S.E.,
Calgary, Alberta T2C 2G5
Canada
Tel: (403) 279-8619
Fax: (403) 279-5035