**QUALIFICATIONS:**

- Contact the "Authority Having Jurisdiction" for approval.

**DESCRIPTION:**

The Nailor Model 0130GC has been especially designed for garbage chute applications. The damper housing is oversized to ensure the blade curtain, closure springs and fusible link are unobstructed. The round collar is oversized for direct attachment to the outside of the garbage chute. The damper has 100% free area.

**SPECIFICATIONS:**

1. One piece roll-formed galvanized steel frame.
2. UL Listed fusible link (replaceable). 165°F (74°C) standard
3. Interlocking galvanized steel blades.
4. Top blade riveted to frame.
5. Self locking corner.
6. Stainless steel negator closure spring.
7. Blade locking ramp.
8. Mounting collar.

**NOTES:**

1. Standard sizes:  
 20" (508) diameter.  
 22" (559) diameter.  
 24" (610) diameter.  
 Other sizes available upon request.

**OPTIONS:**

Non-standard temperature fusible link. Specify \_\_\_\_\_.

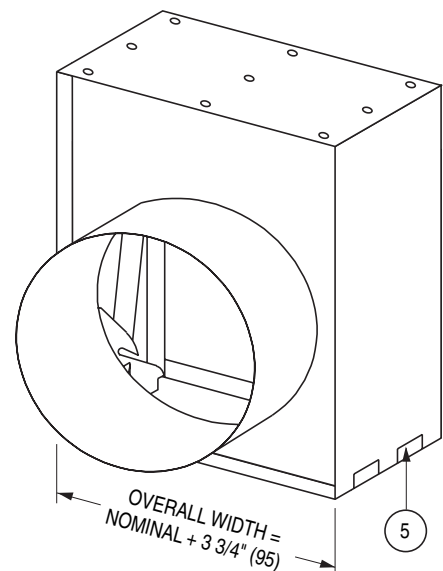
**SCHEDULE TYPE:**
**PROJECT:**
**ENGINEER:**
**CONTRACTOR:**

Dimensions are in inches (mm).

**DATE**
**B SERIES**
**SUPERSEDES**
**DRAWING NO.**

7 - 28 - 10

FD

2 - 18 - 05

0100-7