



**CURTAIN TYPE FIRE DAMPER**  
 3 HR. LABEL • VERTICAL OR HORIZONTAL  
 FOR USE IN STATIC SYSTEMS  
 MODELS 0530V & 0530H TYPE CSR



**QUALIFICATIONS:**

- UL 555 Classified Fire Damper. 3 hr. label. (File # 9492).
- CAN/ULC-S112 Fire Damper Assemblies.
- Meets all the requirements of UL and NFPA 90A for fire dampers in static HVAC systems.
- Meets the requirements for BOCA, SBCCI, UBC, IBC and associated local building codes.
- Meets all the requirements of NBC.
- California State Fire Marshal Listing No. 03225-0935:100.
- City of New York Board of Standards and Appeals. Cal. No. 460-88-SA.

The 0530 curtain fire damper is UL approved for use where local building codes require the protection of HVAC ductwork penetrations in walls, partitions or floors that have a fire resistance rating of up to 4 hours. The 0530 is classified for use only in static "fans off" systems where the HVAC system is automatically shut down in the event of a fire alarm.

Type CSR square or rectangular fire dampers use transition collars to place the curtain blade pack and damper frame out of the airstream, providing 100% free area.

**STANDARD SPECIFICATION:**

- FRAME:** 4 1/4" (108) wide, 24 ga. (0.70) roll-formed G60 galvanized steel.
- BLADES:** Curtain type interlocking blades, 24 ga. (0.70) roll-formed G60 galvanized steel.
- ENCLOSURE:** 22 ga. (0.85) galvanized steel.
- FUSIBLE LINK:** 165°F (74°C) standard. UL Listed.  
212°F (100°C) available.
- BLADE CLOSURE:** Vertical mount model; gravity.  
Horizontal mount models are equipped with stainless steel closure springs and galvanized steel locking ramps.
- MINIMUM SIZE:** Vertical mount: 3" x 3" (76 x 76).  
Horizontal mount: 4" x 4" (102 x 102).
- MAXIMUM SIZE:** Single Section  
Vertical mount: 46" x 42" (1168 x 1067).  
Horizontal mount: 34" x 31" (864 x 767).  
Multiple Section Assembly  
Vertical mount: 106" x 66" (2692 x 1676). See note 2.  
Horizontal mount: 70" x 31" (1778 x 787).

**OPTIONS:**

- Non-standard temperature fusible link. Specify \_\_\_\_\_.
- LP Unsealed. Suitable for low pressure systems.
- HP Sealed. Suitable for medium/high pressure systems. Externally caulked. (Up to 6" w.g./1.5 kPa).
- Factory Sleeve. Available in 10 (3.5) through 22 ga. (0.85) galvanized steel and in lengths required for application. Specify : \_\_\_\_\_ length. \_\_\_\_\_ ga.

**NOTES:**

1. See sizing chart for relationship of duct size and damper size. Refer to drawings SC1 and SC2.
2. Individual sections of multiple section assembly not to exceed 36" x 36" (914 x 914).
3. Building codes and UL Classification require damper installation in accordance with manufacturer's instructions. Refer to appropriate model installation instructions.

Manufactured by members of S.M.W.I.A.

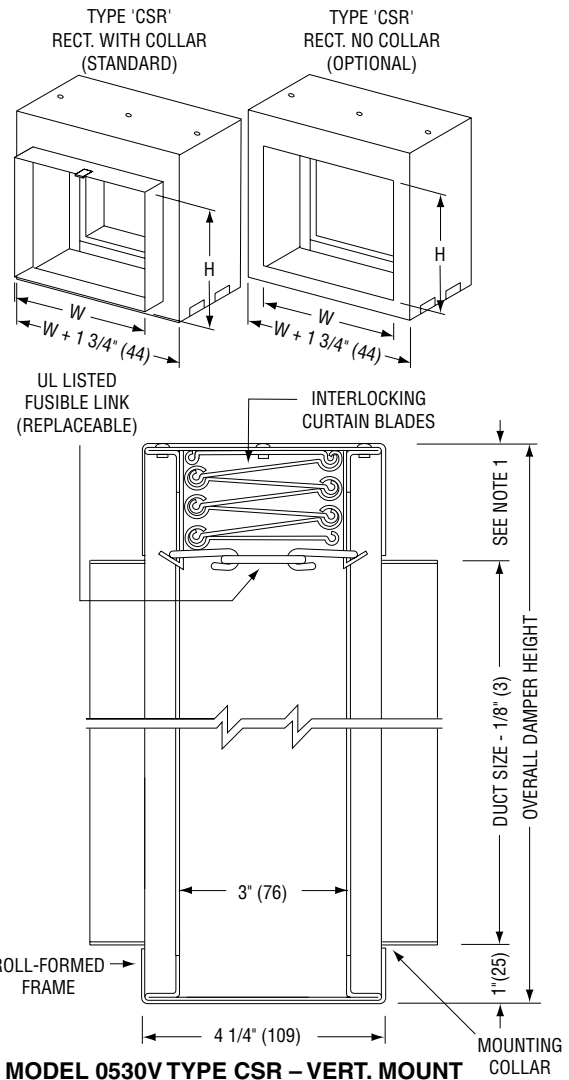

**MODEL 0530V TYPE CSR – VERT. MOUNT**

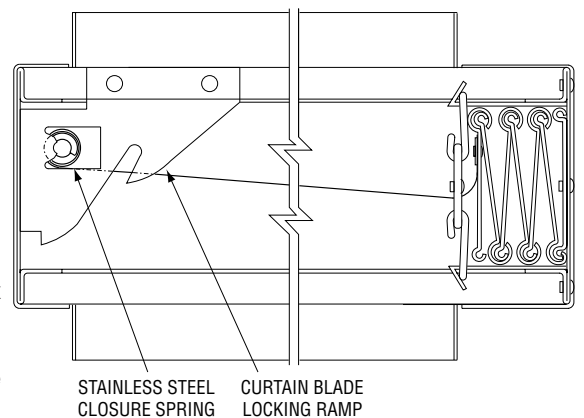

**MODEL 0530H TYPE CSR – HORIZONTAL MOUNT**

Dimensions are in inches (mm).

<b>SCHEDULE TYPE:</b>				
<b>PROJECT:</b>				
<b>ENGINEER:</b>	<b>DATE</b>	<b>B SERIES</b>	<b>SUPERSEDES</b>	<b>DRAWING NO.</b>
<b>CONTRACTOR:</b>	10 - 6 - 06	FD	3 - 1 - 05	0500-4