



THINLINE CURTAIN TYPE FIRE DAMPER
3 HR. LABEL • VERTICAL MOUNT
FOR USE IN STATIC SYSTEMS
MODEL 0570V TYPE A



QUALIFICATIONS:

- UL 555 Classified Fire Damper. 3 hr. label. (File # 9492).
- CAN/ULC-S112 Fire Damper Assemblies.
- Meets all the requirements of UL and NFPA 90A for fire dampers in static HVAC systems.
- Meets the requirements for BOCA, SBCCI, UBC, IBC and associated local building codes.
- Meets all the requirements of NBC.
- California State Fire Marshal Listing No. 03225-0935:100.
- City of New York Board of Standards and Appeals. Cal. No. 460-88-SA.

The 0570 curtain fire damper is UL approved for use where local building codes require the protection of HVAC ductwork penetrations in walls and partitions that have a fire resistance rating of up to 4 hours. The 0570 is classified for use only in static "fans off" systems where the HVAC system is automatically shut down in the event of a fire alarm.

Thinline fire dampers are only 2" (51) deep and permit installation in narrow fire partitions, transfer openings, behind grilles or in any application where clearance is restricted.

STANDARD SPECIFICATION:

- FRAME:** 2" (51) wide, 22 ga. (0.85) roll-formed G60 galvanized steel.
- BLADES:** Curtain type interlocking blades, 22 ga. (0.85) roll-formed G60 galvanized steel.
- FUSIBLE LINK:** 165°F (74°C) standard. UL Listed. 212°F (100°C) available.
- BLADE CLOSURE:** Vertical mount model; gravity.
- MINIMUM SIZE:** 4" x 4" (102 x 102).
- MAXIMUM SIZE:** Vertical mount: 36" x 60" (914 x 1524). Multiple Section Assemblies are not permitted.

OPTIONS:

- Non-standard temperature fusible link. Specify _____.
- Factory Sleeve. Available in 10 (3.5) through 22 ga. (0.85) galvanized steel and in lengths required for application. Specify : _____ length. _____ ga.
- Type 'B' Model 0580
Minimum Size: 4" x 3" (102 x 76).
Maximum Size: Vertical mount: 36" x 50" (914 x 1270).
- Type 'C' Model 0590 round or flat oval.
Minimum Size: 3" (76) dia.; 4" x 3" (102 x 76) oval.
Maximum Size: Vertical mount: 34" (864) dia.; 34" x 49" (864 x 1245) oval.
- Type 'C' Model 0590 rectangular with collar.
Minimum Size: 3" x 3" (76 x 76).
Maximum Size: Vertical mount: 34" x 49" (864 x 1245).

Type 'C' Option

- LP Unsealed. Suitable for low pressure systems.
- HP Suitable for medium/high pressure systems. Externally caulked. (Up to 6" w.g./1.5 kPa).

Consult submittal dwg. SC3 for duct/damper dim. detail on Type B & C.

NOTES:

- Building codes and UL Classification require damper installation in accordance with manufacturer's instructions. Refer to appropriate model installation instructions.

Manufactured by members of S.M.W.I.A.

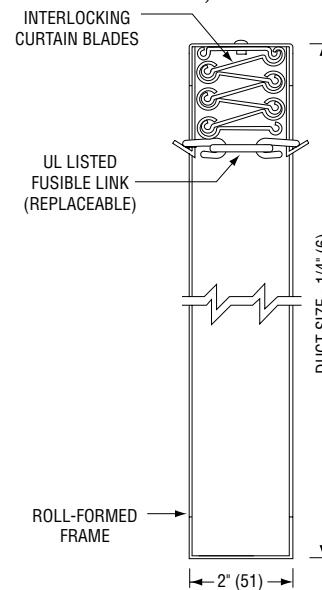
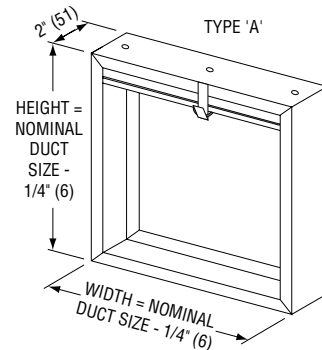

MODEL 0570V – VERTICAL MOUNT

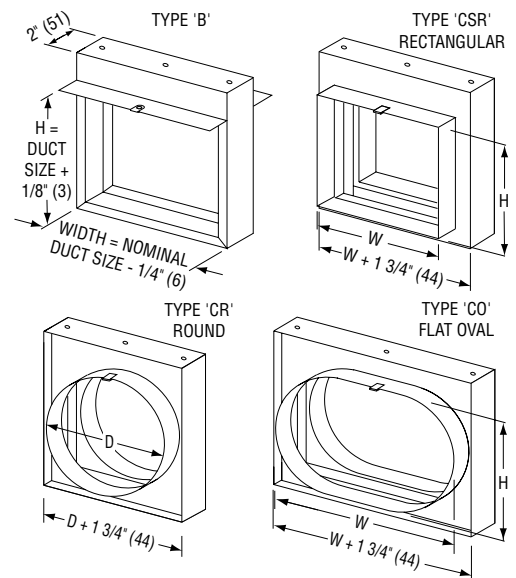

Dimensions are in inches (mm).

SCHEDULE TYPE:				
PROJECT:				
ENGINEER:				
CONTRACTOR:				
DATE	B SERIES	SUPERSEDES	DRAWING NO.	
3 - 1 - 05	FD	8 - 2 - 02	0570	