

MODEL SELECTION:

- 0757 Grille Mount.

QUALIFICATIONS:

- **UL 263 CLASSIFIED CEILING RADIATION DAMPER. Category CABS. (File # 9660)**
1 hour rated for use in UL floor/ceiling design numbers L550/L562/L574/L579 and roof/ceiling design numbers P531/P538/P545. (Equal to designs L546/ L521 and P522 respectively).
- **Meets NFPA 90A requirements**

DESCRIPTION:

Ceiling dampers are designed to function as a heat barrier in air handling openings penetrating fire resistive membrane ceilings. The Model Series 0757 has been especially designed and tested to provide protection and simple installation in specific UL design wood truss ceiling assemblies.

Model 0757 rectangular ceiling damper is designed for use in a fiberglass plenum (boot/register box) by others, that accomodates a steel grille, register or diffuser.

CONSTRUCTION:

1. UL listed fusible link, 212°F (100°C) standard.
2. Blades: 22 ga. (0.85) G60 roll-formed galvanized steel.
3. Blade Insulation: Non-asbestos UL Classified.
4. Damper frame: 22 ga. (0.85). G60 galv. steel.
5. Fiberglass plenum by others.
6. Cutting and installation of collar for UL Classified Class 0 or I Flexible Air Duct connection by others.
7. Damper sub-frame with plaster flange. Min. 26 ga. (0.55) galvanized steel.
8. Steel grille/register/diffuser (by Nailor or others). Bottom of damper sub-frame is flush with ceiling. Standard depth for grille clearance is 2 1/2" (64)

OPTIONS:

1. Non-standard temp. UL listed fusible link
 165°F (74°C)
2. Optional Damper Styles:
 0714 Single Blade Damper
 0720 Low Profile Curtain Damper
3. Installation Support Angles. 26" (660) long.
 ISA 2 @ 3/4" x 3/4" x 16 ga. (19 x 19 x 1.6) or
 ISB 2 @ 1 1/2" x 1 1/2" x 22 ga. (38 x 38 x 0.85)

NOTES:

Minimum Size: 6" W x 4" H (152 x 102)

Maximum Size: 21" W x 18" H (533 x 457)

Building code and UL Classification require damper installation in accordance with manufacturer's instructions. See Doc. IOM-CRD0757INST.

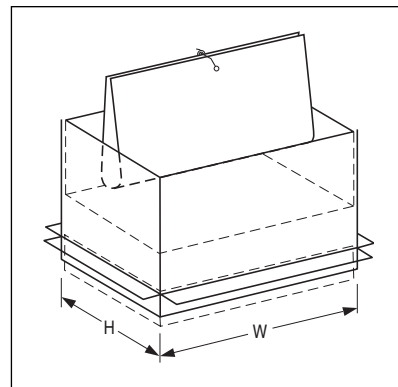
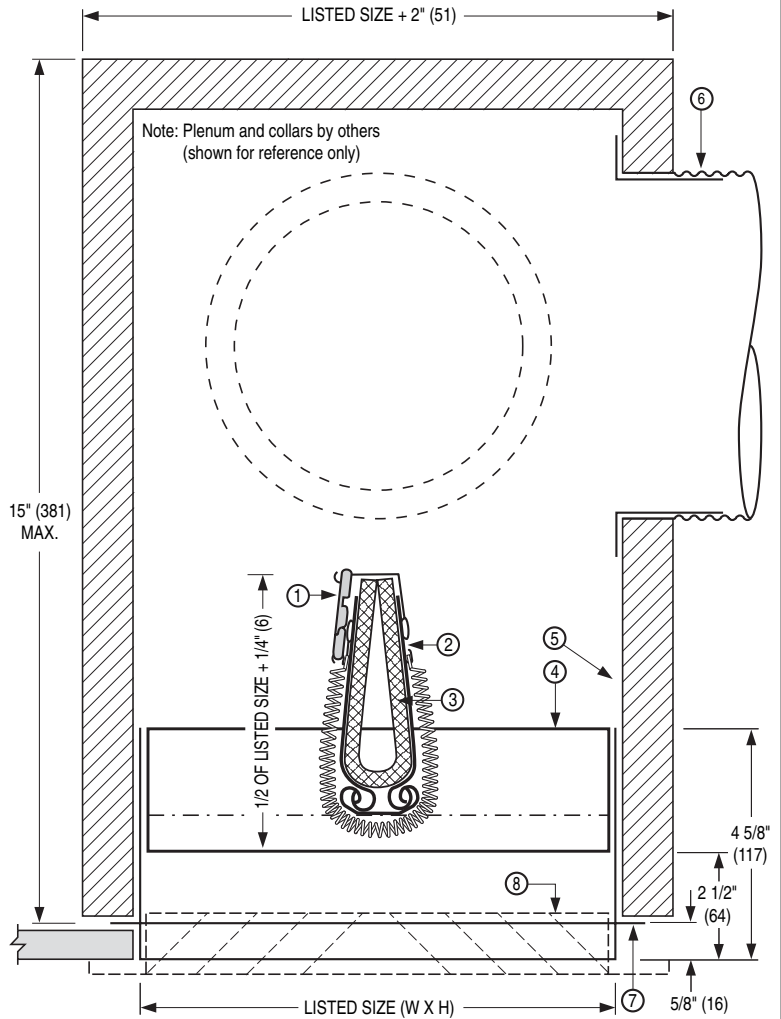

Note:

0716 style damper shown. 0714 Single Blade or 0720 Low Profile Curtain Damper also available. See Options #2.

Dimensions are in inches (mm).

SCHEDULE TYPE:				
PROJECT:				
ENGINEER:				
CONTRACTOR:				
DATE	B SERIES	SUPERSEDES	DRAWING NO.	
10 - 12 - 06	0700	1 - 27 - 06	0757	