



**CEILING RADIATION DAMPER
FOR WOOD TRUSS CEILING ASSEMBLIES
INSULATED REGISTER BOX • SIDE INLET
MODEL: 0759**



QUALIFICATIONS:

- **UL 263 CLASSIFIED CEILING RADIATION DAMPER. Category CABS. (File #R9660)**
1 hour rated for use in UL floor/ceiling design numbers L550/L574/L579 and roof/ceiling design numbers P531/P545 (Similar in construction to designs L521/L546 and P522).
- **Meets NFPA 90A requirements**

DESCRIPTION:

Ceiling dampers are designed to function as a heat barrier in air handling openings penetrating fire resistive membrane ceilings. The model 0759 has been especially designed and tested to provide protection and simple installation in specific UL design wood truss ceiling assemblies.

The 0759 assembly consists of a rectangular ceiling damper recessed in an internally insulated sheet metal register box (boot) with a round 90° side inlet collar, that accommodates a steel grille or register.

CONSTRUCTION:

1. UL listed fusible link, 212°F (100°C) standard.
2. Blade: 22 ga. (0.85) G60 roll-formed galvanized steel.
3. Blade Insulation: Non-asbestos UL Classified.
4. Damper frame: 22 ga. (0.85) G60 galvanized steel.
5. Internal Insulation: 1 1/2" (38) R-6.3 value.
6. Steel plenum: 28 ga. (0.47) min. with round connection collar.
7. UL Classified Class 0 or I Flexible Air Duct connection by others.
8. Plaster flange.
9. Steel grille/register (by Nailor or others). Standard depth for grille clearance is 2 1/2" (64).

OPTIONS:

1. Non-standard temp. UL listed fusible link
 - 165 165°F (74°C)
2. Installation Support Angles. 26" (660) long.
 - ISA 2 @ 3/4" x 3/4" x 16 ga. (19 x 19 x 1.6) or
 - ISB 2 @ 1 1/2" x 1 1/2" x 22 ga. (38 x 38 x 0.85)

NOTE:

Building code and UL Classification require damper installation in accordance with manufacturer's instructions.
See Doc. IOM-CRD0758INST.

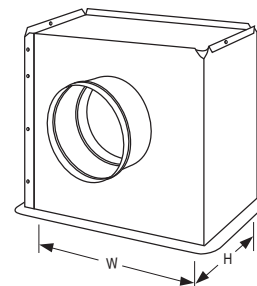
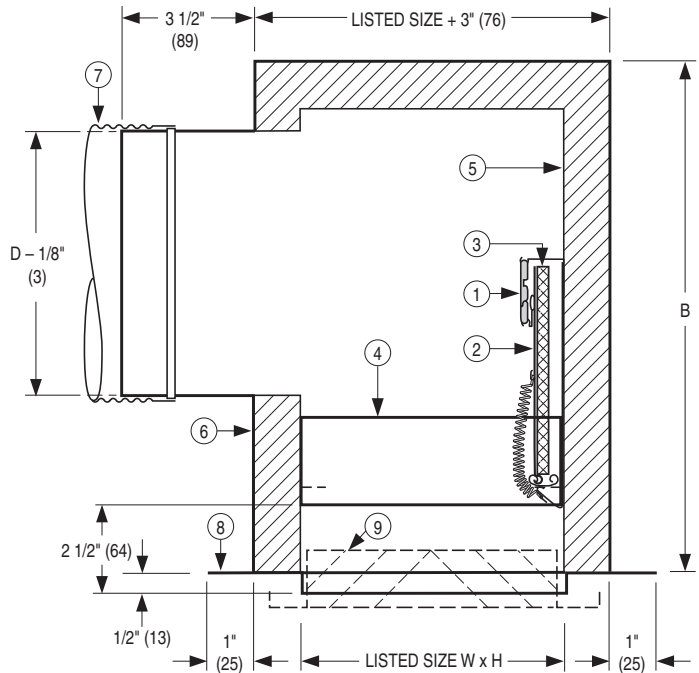

Dimensional Data:

Available Sizes		B
W x H	Nom. Duct Size D	
8 x 4 (203 x 102)	4", 5" (102, 127) dia.	12 (305)
10 x 4 (254 x 102)	4", 5", 6" (102, 127, 152) dia.	
12 x 4 (305 x 102)	6", 7", 8" (152, 178, 203) dia.	
8 x 6 (203 x 152)	6" (152) dia.	
10 x 6 (254 x 152)	5", 6", 7" (127, 152, 178) dia.	
12 x 6 (305 x 152)	6", 7", 8", 9" (152, 178, 203, 229) dia.	
8 x 8 (203 x 203)	5", 6" (127, 152) dia.	12 (305)
10 x 8 (254 x 203)	7", 8" (178, 203) dia.	
12 x 8 (305 x 203)	7", 8" (178, 203) dia.	
10 x 10 (254 x 254)	7", 8" (178, 203) dia.	
12 x 12 (305 x 305)	8" (203) dia.	12 (305)
	9", 10" (229, 254) dia.	14 (356)

W x H = Nominal Grille/Register Size

SCHEDULE TYPE:	Dimensions are in inches (mm).			
PROJECT:				
ENGINEER:	DATE	B SERIES	SUPERSEDES	DRAWING NO.
CONTRACTOR:	6 - 24 - 09R	0700	1 - 9 - 08	0759