



LOW LEAKAGE CONTROL DAMPER STEEL • STANDARD PERFORMANCE MODELS: 1010 & 1020 WITH 13G OPTIONAL 13 GA. FRAME

The 1010/20 Series with optional 13 ga. frame offer low leakage and high value provided in a traditional 13 ga. frame that is fully welded for maximum strength and rack-free installation. For use in low to medium velocity and pressure commercial HVAC applications, the low cost, high quality dampers meet the frequently specified leakage criteria of less than 10 cfm per sq. ft at 4" w.g. (0.5% at 2000 fpm). The design features include a triple-vee blade design that maximizes strength and zero maintenance concealed linkage (out of the air stream) for reduced pressure drop and air turbulence.

STANDARD CONSTRUCTION:

- FRAME:** 5" x 7/8" x 13 ga. (127 x 22 x 2.4) galvanized steel hat channel with die-formed corner gussets. Low profile (flat top and bottom) on dampers 10" (254) high and under.
- BLADES:** 6" (152) wide on 5 1/2" (140) centers. 16 ga. (1.6) galvanized steel triple-vee design. Parallel or opposed action.
- LINKAGE:** Concealed type totally enclosed within the frame and out of the airstream. Plated steel.
- BEARINGS:** 1/2" (13) dia. Celcon®.
- AXLES:** 1/2" (13) dia. plated steel double bolted to blades.
- DRIVE SHAFT:** 6" (152) long x 1/2" (13) dia. rigid drive shaft on all single section dampers. A 1/2" (13) or 1" (25) dia. factory installed jackshaft is standard on all multiple section dampers. See multi-section detail 1000 MSI.
- BLADE SEALS:** Dual durometer bulb type extruded PVC.
- JAMB SEALS:** Compression type cambered metal.
- MINIMUM SIZE:** Single blade (parallel): 6" x 4" (152 x 102).
Two blades (parallel or opposed): 6" x 10" (152 x 254).
- MAXIMUM SIZE:** Single section: 48" x 72" (1220 x 1829).
Multiple section assembly - unlimited.

TEMPERATURE RANGE: -50°F to +180°F (-45°C to +82°C).

OPTIONS:

- BO Oilite bearings
- AMP Actuator mounting side plate
- DLO Lock-on drive shaft
- Other _____.

Nailor offers a wide selection of pneumatic and electric actuators for factory or field installation.

PERFORMANCE DATA - AIR LEAKAGE (DAMPER CLOSED)

DAMPER WIDTH	MAXIMUM SYSTEM PRESSURE	MAXIMUM SYSTEM VELOCITY	LEAKAGE *	
			% OF MAX. FLOW	CFM/SQ. FT.
48" (1219)	2.5" w.g.	2000 FPM	0.18	3.5
36" (914)	3.0" w.g.	2000 FPM	0.20	4.0
24" (610)	4.0" w.g.	2000 FPM	0.23	4.5
12" (305)	5.0" w.g.	2000 FPM	0.33	6.6

* Leakage information is based upon a pressure differential of 1" w.g. tested per AMCA Standard 500-D, Fig. 5.5.

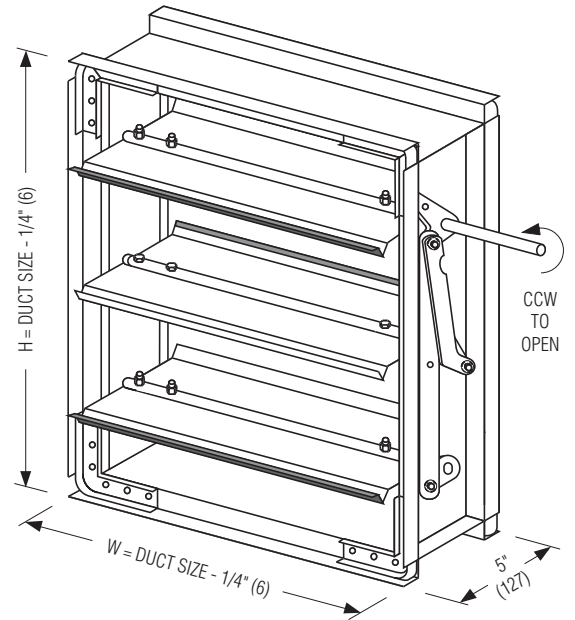

MODEL 1010 WITH 13 GA. FRAME PARALLEL BLADE

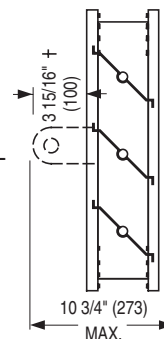

MODEL 1020 WITH 13 GA. FRAME OPPOSED BLADE

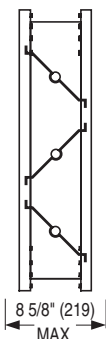

† jackshaft standard on multiple section dampers.

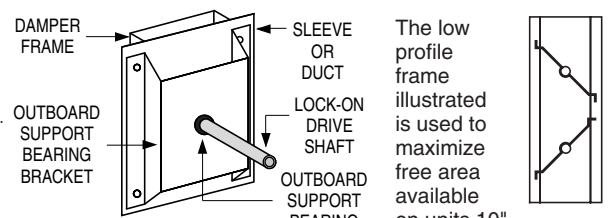

Optional lock-on drive shaft support bracket detail.

The low profile frame illustrated is used to maximize free area available on units 10" (254) high and under.

PRESSURE DROP (IN. W.G.)

DAMPER SIZE	APPROACH VELOCITY (FPM)			
	750	1000	1500	2000
24" x 24" (610 x 610)	.016	.030	.07	.14
36" x 36" (914 x 914)	.013	.023	.05	.09
48" x 48" (1219 x 1219)	.010	.020	.03	.07

Tested per AMCA Standard 500-D, Fig. 5.3.

SCHEDULE TYPE:

PROJECT:

ENGINEER:

CONTRACTOR:

Dimensions are in inches (mm).

DATE	A SERIES	SUPERSEDES	DRAWING NO.
6 - 30 - 04	1000	10 - 23 - 02	1000-1B