



# STANDARD CONTROL DAMPER STEEL • STANDARD PERFORMANCE MODELS: 1012 & 1022

The 1012/22 Series are Nailor's most widely used unsealed dampers and are the standard choice for use in the majority of low to medium pressure and velocity commercial HVAC systems. They are low cost, high quality dampers that meet or exceed the majority of standard specification requirements. The design features include a sturdy hat channel frame with die-formed corner gussets for reinforcement and structural strength equivalent to 13 gauge channel type frames, a triple-vee blade design that maximizes strength and zero maintenance concealed linkage (out of the air stream) for reduced pressure drop and air turbulence.

### STANDARD CONSTRUCTION:

- FRAME:** 5" x 7/8" x 16 ga. (127 x 22 x 1.6) galvanized steel hat channel with die-formed corner gussets. Low profile (flat top and bottom) on dampers 10" (254) high and under.
- BLADES:** 6" (152) wide on 5 1/2" (140) centers. 16 ga. (1.6) galvanized steel triple-vee design. Parallel or opposed action.
- LINKAGE:** Concealed type totally enclosed within the frame and out of the airstream. Plated steel.
- BEARINGS:** 1/2" (13) dia. Celcon®.
- AXLES:** 1/2" (13) dia. plated steel double bolted to blades.
- DRIVE SHAFT:** 6" (152) long x 1/2" (13) dia. lock-on drive shaft on all single section dampers. A 1/2" (13) or 1" (25) dia. factory installed jackshaft is standard on all multiple section dampers. See multi-section detail 1000 MSI.
- MINIMUM SIZE:** Single blade (parallel): 6" x 4" (152 x 102).  
Two blades (parallel or opposed): 6" x 10" (152 x 254).
- MAXIMUM SIZE:** Single section: 48" x 72" (1220 x 1829).  
Multiple section assembly - unlimited.

**TEMPERATURE RANGE:** -50°F to +180°F (-45°C to +82°C).

### OPTIONS:

- BO Oilite bearings
- BSP Polyurethane foam blade seals
- JSM Metallic jamb seals
- AMP Actuator mounting side plate
- 304 Stainless Steel Construction
- Other \_\_\_\_\_

Nailor offers a wide selection of pneumatic and electric actuators for factory or field installation.

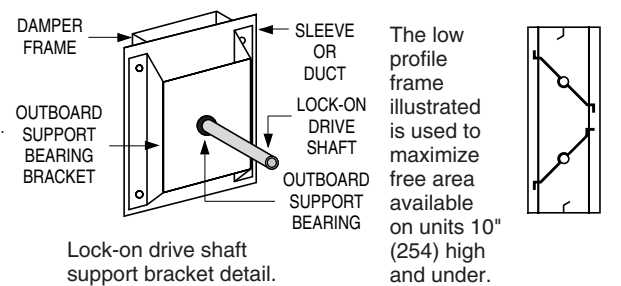
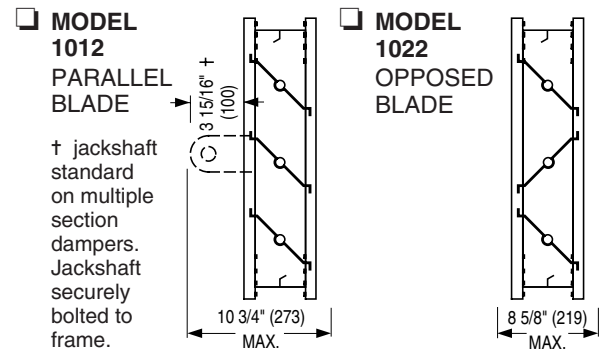
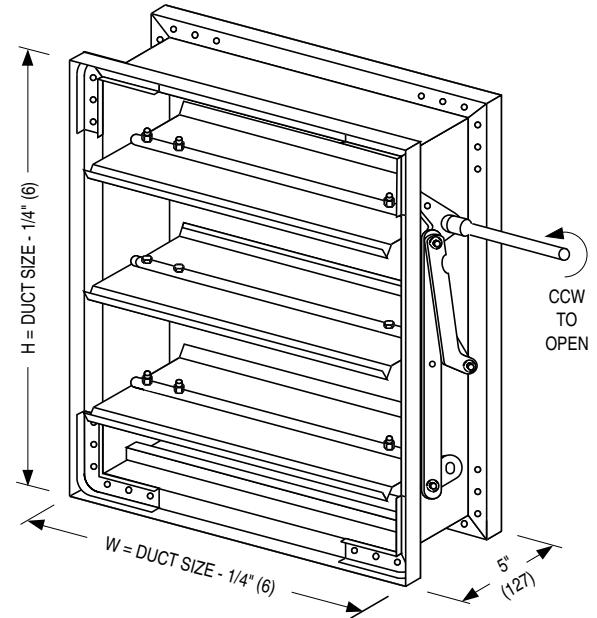

### PERFORMANCE DATA - AIR LEAKAGE (DAMPER CLOSED)

DAMPER WIDTH	MAXIMUM SYSTEM PRESSURE	MAXIMUM SYSTEM VELOCITY	LEAKAGE *			
			W/O SEALS		W/SEALS	
			% OF MAX. FLOW	CFM/ SQ. FT.	% OF MAX. FLOW	CFM/ SQ. FT.
48" (1219)	2.5" w.g.	2000 FPM	1.90	38	0.48	9.5
36" (914)	3.0" w.g.	2000 FPM	2.15	43	0.54	10.8
24" (610)	4.0" w.g.	2000 FPM	2.35	47	0.57	11.3
12" (305)	5.0" w.g.	2000 FPM	3.10	62	0.80	16.0

\* Leakage information is based upon a pressure differential of 1" w.g. tested per AMCA Standard 500-D, Fig. 5.5.

### PRESSURE DROP (DAMPER OPEN), IN. W.G.

DAMPER SIZE	APPROACH VELOCITY (FPM)			
	750	1000	1500	2000
24" x 24" (610 x 610)	.016	.030	.07	.14
36" x 36" (914 x 914)	.013	.023	.05	.09
48" x 48" (1219 x 1219)	.010	.020	.03	.07

Tested per AMCA Standard 500-D, Fig. 5.3.

<b>SCHEDULE TYPE:</b>	Dimensions are in inches (mm).			
<b>PROJECT:</b>				
<b>ENGINEER:</b>	<b>DATE</b>	<b>C SERIES</b>	<b>SUPERSEDES</b>	<b>DRAWING NO.</b>
<b>CONTRACTOR:</b>	6 - 30 - 04	1000	10 - 5 - 99RR	1000-2