



**MODULATING SMOKE DAMPER**  
 AIRFOIL BLADE • HIGH PERFORMANCE  
 ULTRA-LOW LEAKAGE • SQUARE, RECT. OR  
 OVAL DUCT CONNECTION  
**MODEL: 1213M (TYPE C SLEEVE ENCLOSURE)**



**QUALIFICATIONS:**

- **UL 555S CLASSIFIED SMOKE DAMPER (File # R9492) Leakage Class I at 250°F elevated temperature.**
- **Meets NFPA 90A, 92A, 92B, 101 and 105 as well as IBC and NBC (Canada) Building Code requirements.**
- **California State Fire Marshal Listing No. 03230-0935:107.**
- **City of New York MEA# 366-03-M.**
- **Maximum velocity: 2000 fpm @ 4" w.g.**

The 1210M Series modulating dampers are classified for use as a volume control damper in applications where building codes require a leakage rated smoke damper as part of a static smoke control or dynamic smoke management system.

The 1210M Series has been especially designed and tested to offer premium performance. The 1210M Series provides the lowest leakage class available and is qualified for vertical or horizontal installation with airflow in either direction. Airfoil blade design and elimination of blade sills, top and bottom, provide lowest pressure drop. Unique inter-locking double skin blade design eliminates combustible blade seals and provides flame and smoke seal under fire conditions.

**STANDARD SPECIFICATION:**

**Frame:** 5" x 7/8" x 16 ga. (127 x 22 x 1.6) galvanized steel hat channel.

**Blades:** 14 ga. (2.0) equivalent galvanized steel formed airfoil on 5 1/2" (140) centers.

**Linkage:** Concealed in frame. 12 ga. (2.7) plated steel.

**Bearings:** 1/2" (13) dia. self-lubricating oilite bronze.

**Axles:** 1/2" (13) dia. plated steel double bolted to blades.

**Jackshaft:** 1/2" (13) dia. cadmium plated steel.

**Jamb Seals:** Cambered stainless steel.

**Sizes (Duct W x H):**

Velocity/ Pressure Rating	Elevated Temp. °F	Minimum		Maximum	
		Single Section		Single Section	Multiple Section
		Vertical/Horizontal	Vertical/Horizontal	Vertical/Horizontal	Vertical/Horizontal
24	250	4" x 4" (203 x 102) diameter. Overall damper width is 8" (203) min.; min. overall height is 6" (152), 8" for duct sizes over 16 x 4 (406 x 102).		34" x 46" (864 x 1168)	142" x 94" (3607 x 2388) or 286" x 46" (7264 x 1168)

**SLEEVE/ENCLOSURE SELECTION:**

- 1213M** Standard factory sleeve (caulked to UL requirements) 16" long x 20 ga. (406 x 1.0).
- 1213M** Non-standard sleeve. Specify \_\_\_\_\_ length \_\_\_\_\_ ga. Available up to 36" (914) in length and 10 through 20 ga. (3.5 through 1.0).

**LEAKAGE CLASS/ELEVATED TEMPERATURE: I @ 250°F**

**DYNAMIC VELOCITY/PRESSURE RATING: 24 2000 fpm @ 4" w.g.**

**ACTUATOR SELECTION:**

- Electric  Pneumatic

**ACTUATOR LOCATION:**

- External  Internal (in the airstream)

**ACTUATOR FAIL POSITION: Closed.**

**SCHEDULE TYPE:**

**PROJECT:**

**ENGINEER:**

**CONTRACTOR:**

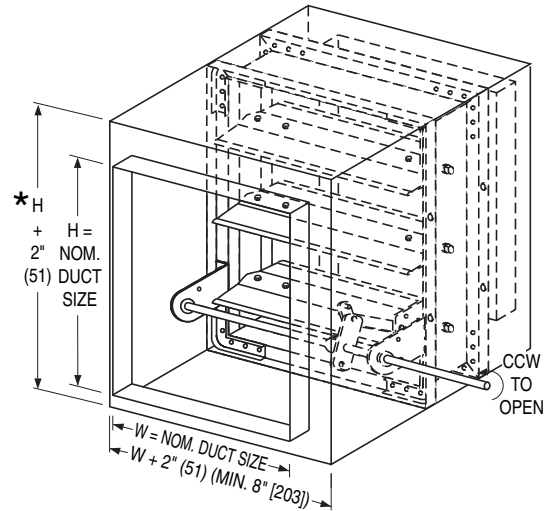

\* 6" (152) or 8" (203) min. (See Min. Duct Size)

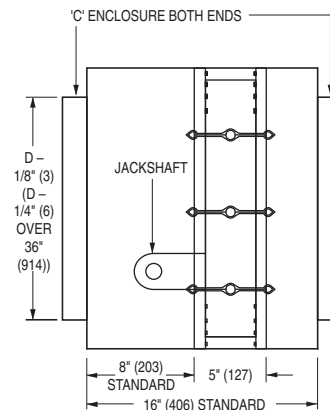
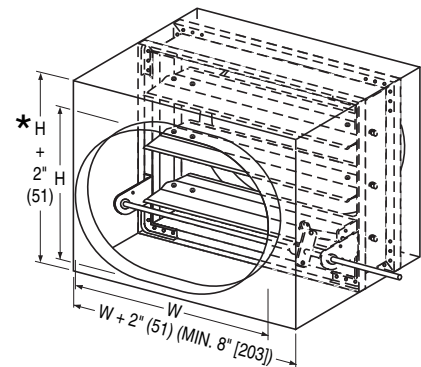

**OPTIONS:**

- BS** Stainless steel bearings
- MLS-300** Position indicator switch pack

For installation instructions, see IOM-SDINST.

Dimensions are in inches (mm).

DATE	B SERIES	SUPERSEDES	DRAWING NO.
5 - 7 - 12	1200	8 - 21 - 08	1210M-4