



COMBINATION FIRE/SMOKE DAMPER
ROUND
MODEL: 1290FS



QUALIFICATIONS:

- **UL 555 & CAN/ULC-S112 CLASSIFIED DYNAMIC FIRE DAMPER**
1 1/2 hr. Label (File #'s R9492 & R19569).
- **UL 555S CLASSIFIED SMOKE DAMPER (File # R9492)**
Leakage Class I at 250°F or 350°F elevated temperature.
- **Meets NFPA 80, 90A, 92A, 92B, 101 and 105 as well as IBC and NBC (Canada) Building Code requirements.**
- **California State Fire Marshal Listing No. 03225-0935:106.**
- **City of New York. MEA# 366-03-M.**
- **Maximum velocity 2000 fpm @ 4" w.g.**

The 1290FS Damper is ideal for applications where building codes require both a fire damper for the protection of ductwork penetrations in walls or floors that have a fire resistance rating of up to 2 hours and also require a leakage rated damper for operational smoke control in static or dynamic smoke management systems.

The 1290FS Damper is an economical true round combination fire/smoke damper designed and qualified for round ductwork passing through metal stud drywall partitions or masonry walls.

The 1290FS offers the lowest leakage class available and is qualified for installation with airflow in either direction.

STANDARD SPECIFICATION:

- Frame:** 20 gauge (1.0) galvanized steel integral sleeve and retaining plates.
- Blade:** 2 x 20 gauge (1.0) galvanized steel laminated together, 14 gauge (2.0) equivalent thickness.
- Linkage:** Jackshaft to blade.
- Bearings:** 1/2" (13) dia. self-lubricating oilite bronze.
- Axles:** 1/2" (13) dia. plated steel double bolted to blades.
- Jackshaft:** 1/2" (13) dia. cadmium plated steel.
- Blade Seal:** Silicone rubber. Peripheral gasket sandwiched between two piece blade.

Heat Responsive Device (Controlled Closure):

ERL (Electric Resettable Link) is standard on dampers with electric actuators: 250°F (121°C) standard. 165°F (74°C), 212°F (100°C) and 350°F (176°C) available.

PRL (Pneumatic Replaceable Link) is standard on dampers with pneumatic actuators: 212°F (100°C) standard. 165°F (74°C) and 280°F (138°C) available.

Available Sizes: 6" (152) through 24" (610) diameter in nominal 2" (51) increments. Vertical or horizontal installation.

LEAKAGE CLASS / ELEVATED TEMPERATURE:

- 250°F (Standard)
- 350°F (Optional)

ACTUATOR SELECTION:

- Electric** **Pneumatic** Specify model _____ .
- Actuators are mounted out of airstream only.

ACTUATOR FAIL POSITION:

Normally Closed. (Normally Open actuators are not available)

OPTIONS:

- 304** 304 Stainless steel construction
- MLS-300** Position indicator switch pack
- MLS-400** Electric Fire Sensor (Re-openable control system). Includes dual heat sensors (165°F and 250°F or 350°F) and position indicator switch pack.

For installation instructions, see IOM-1290FSINST.

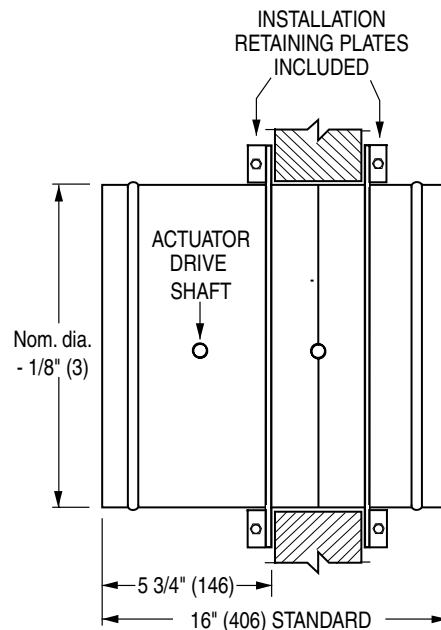
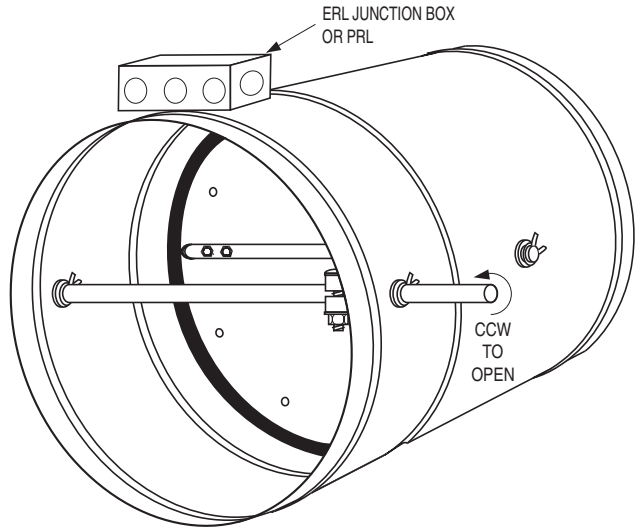

Wall Thickness	Minimum Sleeve Length
4 to 8 (102 to 203)	16 (406)
10 to 12 (254 to 305)	20 (508)
14 to 16 (356 to 406)	24 (610)

SCHEDULE TYPE:		Dimensions are in inches (mm).			
PROJECT:					
ENGINEER:	DATE	B SERIES	SUPERSEDES	DRAWING NO.	
CONTRACTOR:	8 - 21 - 08	1200	3 - 23 - 06	1290FS-1	