



# HEAVY DUTY CONTROL DAMPERS

STEEL • AIRFOIL BLADES • FACE LINKAGE

MODELS: 1530 & 1540  
1537 & 1547

The Nailor 1530-1547 Series is a heavy duty U-channel frame industrial damper with airfoil blades. Features include an adjustable face linkage design and stainless steel pivot pins which provide smooth control and easy maintenance. It is designed for "in-duct" mounting applications to control airflow and provide positive shutoff in HVAC or process air systems. Available with parallel or opposed blade operation. A variety of options make this damper extremely versatile and enable it to be tailored to the specific application.

**RATINGS** (see page 2 for specific limitations):

- Pressure: 10.0-32.0" w.g. (2486-7955 Pa).
- Velocity: 4000-6000 fpm (20.3-30.5 m/s).
- Temperature: 250°F (121°C) standard. Dampers can be supplied for temperatures between 250°F (121°C) and 400°F (204°C) by increasing blade/frame clearance. Consult factory.

**STANDARD CONSTRUCTION:**

- FRAME:** 3" x 1" x 12 ga. (76 x 25 x 2.8) galvanized steel U-channel.
- BLADES:** 16 ga. (1.6) galvanized steel double skin airfoil blade, 8" (203) maximum width. Parallel or opposed blade action.
- LINKAGE:** Plated steel face linkage riveted to blade, in airstream.
- AXLES:** Models 1530/1540: 1/2" (13) dia. plated steel.  
Models 1537/1547: 3/4" (19) dia. plated steel.  
Axles are double bolted to blades.
- BEARINGS:** Self-lubricating sintered stainless steel sleeve type, pressed into frame.
- DRIVESHAFT:** 1/2" (13) or 3/4" (19) dia. (see Axles) plated steel. A 1" (25) dia. jackshaft is standard on multiple section dampers.
- FINISH:** Mill galvanized.
- MINIMUM SIZE:** Single blade parallel action: 5" x 5" (127 x 127).  
Two blade either action: 8" x 14" (203 x 356).
- MAXIMUM SIZE:** Single section:  
1530/1540: 48" x 96" (1219 x 2438).  
1537/1547: 60" x 96" (1524 x 2438).  
Multiple section assembly: Unlimited size.

**OPTIONS:**

- 304 Type 304 stainless steel construction (all parts within airstream, single section only)
- 316 Type 316 stainless steel construction (all parts within airstream, single section only)
- 14GF 5" x 7/8" x 14 ga. (127 x 22 x 2.0) hat channel frame (galvanized only)
- 14GB 2 x 14 ga. (2.0) blades (galvanized only)
- ASxx Type 304 stainless steel axles only
- BPV PVC blade seals (up to 180°F [83°C])
- BSE EPDM blade seals (up to 250°F [121°C])
- BSS Silicone blade seals (up to 400°F [204°C])

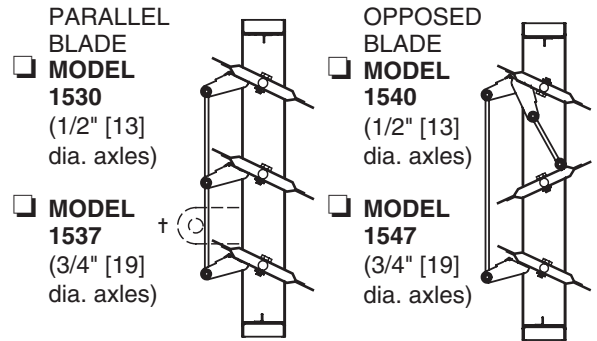
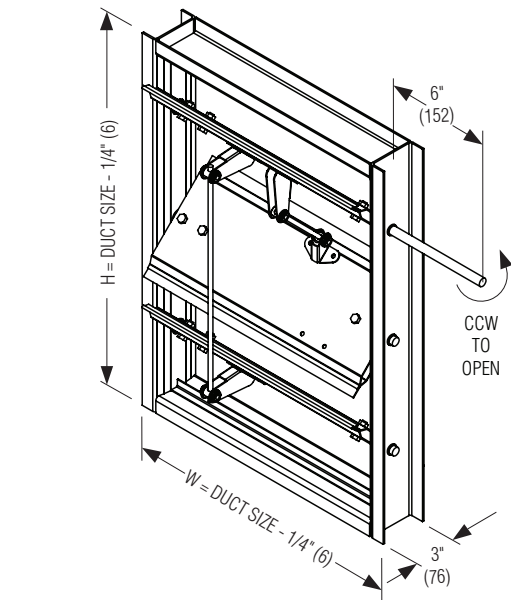

† jackshaft standard on multiple section dampers.

- JSS Stainless steel jamb seals
- LFS Type 304 stainless steel face linkage only
- HLQ Hand locking quadrant for 1/2" (13) dia. shaft
- HDLQ Heavy duty locking hand quadrant for 3/4" (19) dia. shaft or 1" (25) dia. jackshaft
- FMO Factory mounted actuator. Specify \_\_\_\_\_.
- Special Features. Specify: \_\_\_\_\_.

Note: For variations not shown, contact factory.

<b>SCHEDULE TYPE:</b>		Page 1 of 2			
<b>PROJECT:</b>		Dimensions are in inches (mm).			
<b>ENGINEER:</b>	<b>DATE</b>	<b>B SERIES</b>	<b>SUPERSEDES</b>	<b>DRAWING NO.</b>	
<b>CONTRACTOR:</b>	4 - 10 - 07	1500	3 - 28 - 07	1530	



**HEAVY DUTY CONTROL DAMPERS**  
**STEEL • AIRFOIL BLADES • FACE LINKAGE**  
**MODELS: 1530 & 1540**  
**1537 & 1547**

**PERFORMANCE LIMITATIONS:**

Damper Width	Models 1530/1540		Models 1537/1547	
	Max. System Pressure	Max. System Velocity	Max. System Pressure	Max. System Velocity
60" (1529)	N/A	N/A	12.0 in. w.g.	4000 fpm
48" (1219)	10.0 in. w.g.	4000 fpm	17.0 in. w.g.	4000 fpm
36" (914)	15.0 in. w.g.	4000 fpm	22.0 in. w.g.	4000 fpm
24" (610)	19.0 in. w.g.	4000 fpm	27.0 in. w.g.	5000 fpm
12" (305)	24.0 in. w.g.	4000 fpm	32.0 in. w.g.	6000 fpm

Pressure and velocity limitations shown are guidelines for design purposes. Although ratings are on the conservative side, contact Nailor for requirements beyond limitations shown.

**LEAKAGE:**

Damper Width	Models 1530/1540				Models 1537/1547			
	Leakage w/o Seals		Leakage with Seals		Leakage w/o Seals		Leakage with Seals	
	CFM per Sq. Ft.	% of Max. Flow	CFM per Sq. Ft.	% of Max. Flow	CFM per Sq. Ft.	% of Max. Flow	CFM per Sq. Ft.	% of Max. Flow
60" (1529)	N/A	N/A	N/A	N/A	31.0	0.78	4.0	0.10
48" (1219)	31.0	0.78	4.0	0.10	31.0	0.78	4.0	0.10
36" (914)	31.0	0.78	4.0	0.10	31.0	0.78	4.0	0.10
24" (610)	39.0	0.78	8.0	0.16	39.0	0.78	8.0	0.16
12" (305)	59.0	0.98	13.0	0.22	59.0	0.98	13.0	0.22

Leakage data is based upon a pressure differential of 1 in. w.g., tested in accordance with AMCA Standard 500-D, Figure 5.5.

**PRESSURE DROP: SIZE: 36" x 36" (914 x 914)**

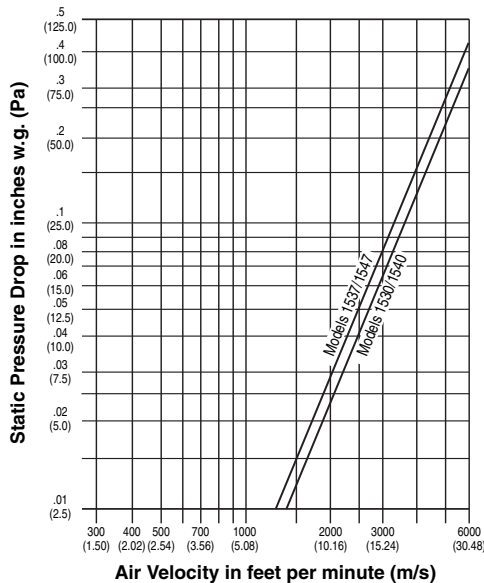

Tested per AMCA Standard 500-D using test set-up figure 5.3, ductwork upstream and downstream.

<b>SCHEDULE TYPE:</b>	Page 2 of 2			
<b>PROJECT:</b>	Dimensions are in inches (mm).			
<b>ENGINEER:</b>	<b>DATE</b>	<b>B SERIES</b>	<b>SUPERSEDES</b>	<b>DRAWING NO.</b>
<b>CONTRACTOR:</b>	4 - 10 - 07	1500	3 - 28 - 07	1530