



FORMED STEEL STATIONARY LOUVER
6" (152) DEEP • J BLADE
MODEL: 1706J

Model 1706J, incorporating J style blades, is an architecturally styled 6" (152) deep formed louver designed with smooth, clean lines that visually compliment any structure's exterior styling. Galvanized steel construction is economical, yet durable and is available with channel or flanged frame. Suitable for use in exhaust and low to medium velocity intake applications, the blade design features a rear water baffle and provides good protection against general weather conditions, with low pressure drop characteristics and a high free area. Model 1706J is engineered to be architecturally appealing as well as mechanically enduring.

STANDARD CONSTRUCTION:

- FRAME:** 6" (152) deep, 18 ga. (1.3) formed galvanized steel.
- BLADES:** 20 ga. (1.0) formed galvanized steel. J style.
- BLADE ANGLE:** Fixed at 45 degrees.
- BLADE SPACING:** Approx. 5 1/2" (140) on centers.
- SCREEN:** 1/2" x 1/2" x 19 ga. (13 x 13 x 1.0) galvanized bird screen in removable frame (adds approximately 3/8" [10] to louver depth).
- FINISH:** Mill.
- MINIMUM SIZE:** 12" wide x 12" high (305 x 305).
- MAXIMUM SINGLE SECTION SIZE:** 60" wide x 96" high (1524 x 2438). Larger louvers will require field assembly of smaller sections.

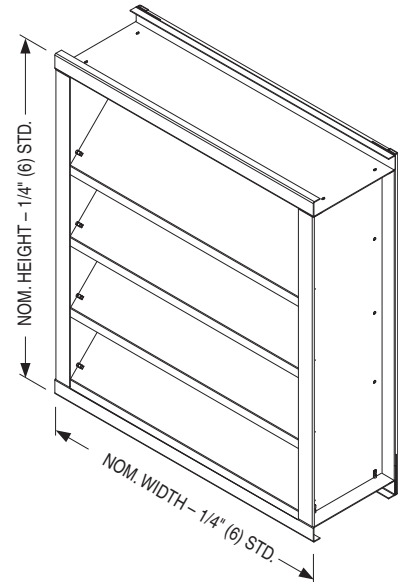

OPTIONS:

- FL** Flanged Frame.
- BSA** Aluminum Bird Screen.
- BSSS** Type 304 S.S. Bird Screen.
- BSN** No Bird Screen.
- ISA** Aluminum Insect Screen.
- ISSS** Type 304 S.S. Insect Screen.
- 18GA** 18 Gauge Construction.
- 16GA** 16 Gauge Construction.
- 304** Type 304 S.S. Construction.
- 316** Type 316 S.S. Construction.
- WE** Welded Construction.
- ESI** Extended Sill.
- FR1** 1" (25) Filter Rack.
- FR2** 2" (51) Filter Rack.
- PAC** Perimeter Anchor Clips.

OPTIONAL FINISHES:

- PC3** Powder Coat AAMA 2603. Color: _____.
- PC4** High Performance Powder Coat AAMA 2604 (Equivalent to 50% Kynar®). Color: _____.
- PC5** Fluoropolymer Powder Coat AAMA 2605 (Equivalent to 70% Kynar®). Color: _____.
- PCC** Prime Coat.

OPTIONAL W x H SIZING (1/4" [6.5] Undersize standard):

- U00** Exact Size.
- U38** Undersize 3/8" (9.5).
- U50** Undersize 1/2" (12.7).

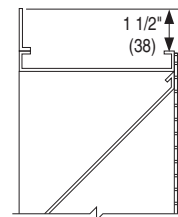
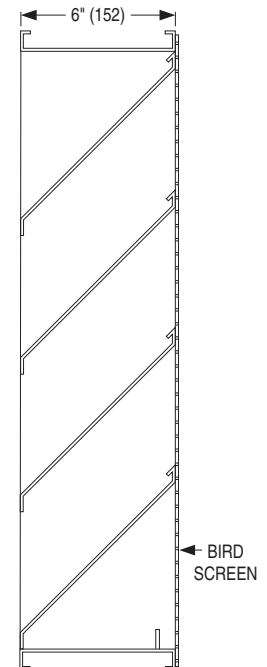

FLANGED FRAME (FL)
(OPTIONAL)

← BIRD SCREEN

SCHEDULE TYPE:
PROJECT:
ENGINEER:
CONTRACTOR:

Page 1 of 2
 Dimensions are in inches (mm).

DATE	B SERIES	SUPERSEDES	DRAWING NO.
12 - 1 - 10	1700	8 - 25 - 09	1706J



FORMED STEEL STATIONARY LOUVER
6" (152) DEEP • J BLADE
PERFORMANCE DATA
MODEL: 1706J

FREE AREA in Square Feet and Square Meters

		Width in Inches and Meters								
		12	18	24	30	36	42	48	54	60
Height in Inches and Meters	12	0.19	0.29	0.39	0.49	0.61	0.71	0.81	0.92	1.02
	0.30	0.02	0.03	0.04	0.05	0.06	0.07	0.08	0.09	0.09
	18	0.47	0.75	1.02	1.29	1.56	1.83	2.11	2.38	2.64
	0.46	0.04	0.07	0.09	0.12	0.14	0.17	0.20	0.22	0.25
	24	0.77	1.20	1.65	2.08	2.52	2.96	3.40	3.84	4.27
	0.61	0.07	0.11	0.15	0.19	0.23	0.27	0.32	0.36	0.40
	30	1.06	1.67	2.27	2.87	3.48	4.09	4.69	5.30	5.90
	0.76	0.10	0.16	0.21	0.27	0.32	0.38	0.44	0.49	0.55
	36	1.35	2.12	2.89	3.66	4.43	5.21	5.98	6.75	7.52
	0.91	0.13	0.20	0.27	0.34	0.41	0.48	0.56	0.63	0.70
	42	1.65	2.58	3.52	4.56	5.40	6.34	7.28	8.21	9.15
	1.07	0.15	0.24	0.33	0.42	0.50	0.59	0.68	0.76	0.85
	48	1.93	3.04	4.15	5.25	6.36	7.46	8.53	9.67	10.77
	1.22	0.18	0.28	0.39	0.49	0.59	0.69	0.79	0.90	1.00
	54	2.22	3.50	4.77	6.04	7.32	8.59	9.86	11.13	12.40
	1.37	0.21	0.33	0.44	0.56	0.68	0.80	0.92	1.04	1.15
60	2.52	3.96	5.39	6.83	8.27	9.71	11.15	12.59	14.03	
1.52	0.23	0.37	0.50	0.63	0.77	0.90	1.04	1.17	1.30	
66	2.81	4.41	6.02	7.62	9.23	10.84	12.44	14.05	15.65	
1.68	0.26	0.41	0.56	0.71	0.86	1.01	1.16	1.31	1.45	
72	3.10	4.88	6.65	8.42	10.19	11.97	13.74	15.51	17.28	
1.83	0.29	0.45	0.62	0.78	0.95	1.11	1.28	1.44	1.61	
78	3.40	5.33	7.28	9.21	11.15	13.09	15.03	16.97	18.90	
1.98	0.32	0.50	0.68	0.86	1.04	1.22	1.40	1.58	1.76	
84	3.68	5.79	7.89	10.00	12.11	14.21	16.32	18.43	20.53	
2.13	0.34	0.54	0.73	0.93	1.13	1.32	1.52	1.71	1.91	
90	3.98	6.25	8.52	10.79	13.07	15.34	17.62	19.89	21.15	
2.29	0.37	0.58	0.79	1.00	1.21	1.43	1.64	1.85	2.06	
96	4.27	6.71	9.15	11.59	14.03	16.46	18.90	21.34	23.78	
2.44	0.40	0.62	0.85	1.08	1.30	1.53	1.76	1.98	2.21	

AIRFLOW/WATER PENETRATION DATA
for 48" x 48" (1219 x 1219) Louver Size

Free Area %	53%
Free Area sq. ft. (sq. m.)	8.53 (0.79)
Free Area Velocity at Point of Beginning Water Penetration at .01 oz./sq. ft. (3 ml/sq. m) (15 min. test duration)	938 fpm (286 m/min.)
Air Volume at 938	8001 cfm (3776 l/s)
Free Area Velocity	
Pressure Drop @ 938 fpm	.15 in. w.g. (37 Pa)

NOTE: To minimize water penetration when sizing intake louvers, select a Free Area Velocity that is **below** the point of beginning water penetration.

PRESSURE DROP

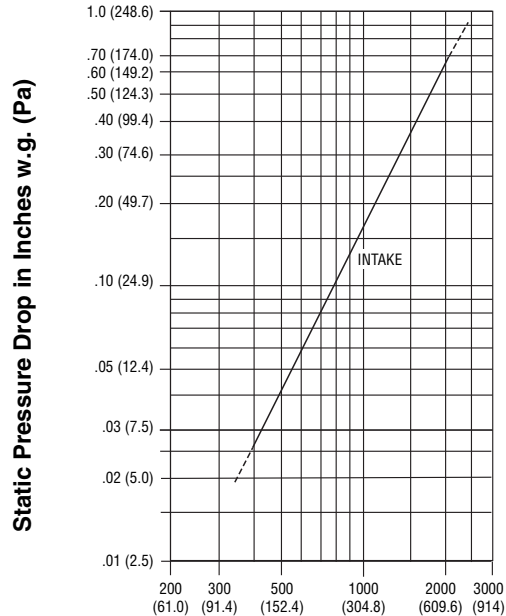

Air Velocity in Feet (Meters) Per Minute Through Free Area
 Louver test size: 48" x 48" (1219 x 1219 mm). Standard air density @ 0.075 lbs/ft³.
 Tested to AMCA Fig. 5.5-6.5.

SCHEDULE TYPE:				
PROJECT:				
ENGINEER:	DATE	B SERIES	SUPERSEDES	DRAWING NO.
CONTRACTOR:	12 - 1 - 10	1700	8 - 25 - 09	1706J