



MANUAL BALANCING DAMPER
STEEL • STANDARD PERFORMANCE
MODELS: 1810 & 1820 WITH CR ROUND
TRANSITIONS OPTION

The 1810CR/20CR Series are Nailor's manual balancing dampers in a low leakage casing with round transition collars and are suitable for use in the majority of commercial low to medium pressure and velocity HVAC systems at an economical cost. Model 1820 with opposed blade action is recommended for the majority of applications.

STANDARD CONSTRUCTION:

FRAME: 5" x 7/8" x 16 ga. (127 x 22 x 1.6) galvanized steel hat channel with die-formed corner gussets. Low profile (flat top and bottom) on dampers 10" (254) high and under.

BLADES: 6" (152) wide on 5 1/2" (140) centers. 16 ga. (1.6) galvanized steel triple-vee design. Parallel or opposed action.

LINKAGE: Concealed type totally enclosed within the frame and out of the airstream. Plated steel.

BEARINGS: 1/2" (13) dia. Celcon®.

AXLES: 1/2" (13) dia. plated steel double bolted to blades.

DRIVE SHAFT: 6" (152) long x 1/2" (13) dia. rigid drive shaft.

CASING: Up to 36" x 36" (914 x 914) 20 ga. (1.0) galvanized steel.

36" x 36" (914 x 914) and up 18 ga. (1.31) galvanized steel.

Casing is tack-welded and caulked against leakage.

MINIMUM SIZE: Single blade: 4" (102) dia..
 Two blades (parallel or opposed): 8" (203) dia..

MAXIMUM SIZE: Single section: 46" (1168) dia..

TEMPERATURE RANGE: -50°F to 250°F (-45°C to 121°C).

OPTIONS:

- HLQ Hand-locking quadrant
- HL2 Hand-locking quadrant with 2" (51) stand-off bracket
- BO Oilite bearings
- 304 Stainless Steel Construction
- Other _____.

PERFORMANCE:

Dampers are designed to operate in a clean, dry environment. For proper operation, dampers must be installed without racking. The hand quadrant must be installed on the indicated drive blade.

Maximum System Pressure: 2.5" w.g. (625 pa).

Maximum Face Velocity: 2000 fpm (10 m/s).

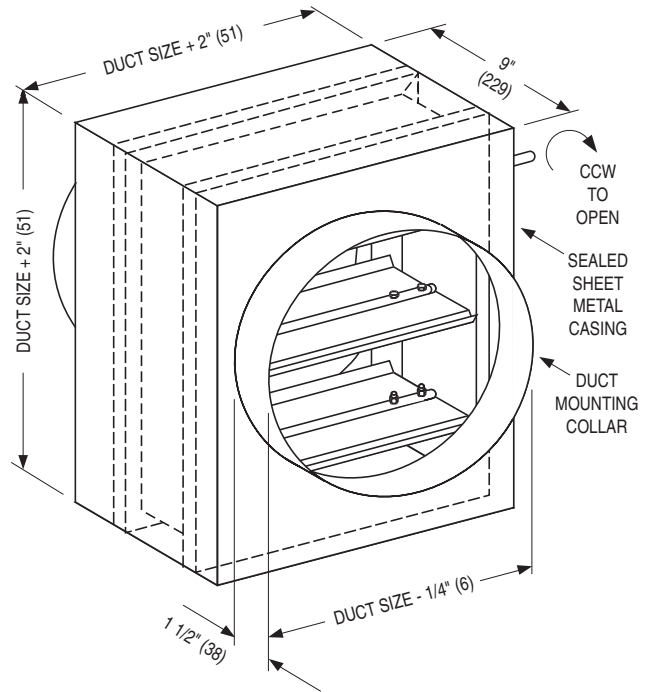

MODEL 1810CR
PARALLEL
BLADE

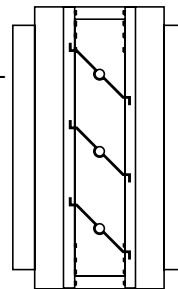

MODEL 1820CR
OPPOSED
BLADE

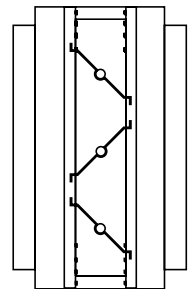

The low profile frame illustrated is used to maximize free area available on units 10" (254) high and under.

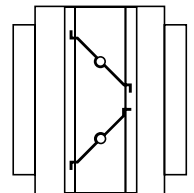

SCHEDULE TYPE:				
PROJECT:				
Dimensions are in inches (mm).				
ENGINEER:	DATE	B SERIES	SUPERSEDES	DRAWING NO.
CONTRACTOR:	1 - 8 - 07	1800	6 - 1 - 02	1800-4