

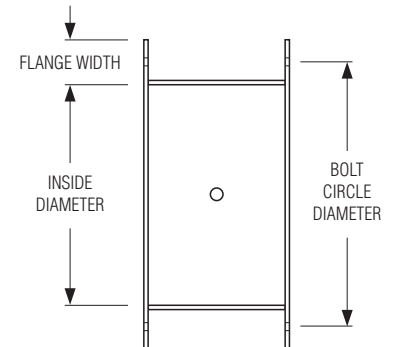

# HEAVY DUTY INDUSTRIAL CONTROL DAMPERS ROUND, SQUARE OR RECTANGULAR STANDARD BOLT HOLE CONFIGURATIONS MODEL SERIES: 1900

## ROUND DAMPERS:

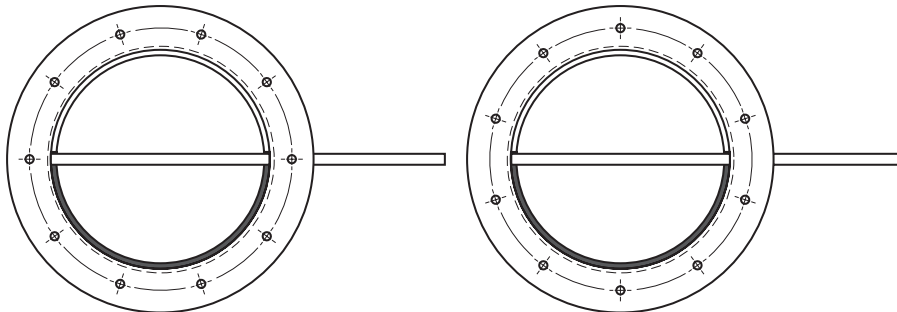

### □ BHAA

Bolt holes aligned with axle

### □ BHAP

Bolt holes aligned perpendicular to axle

Standard bolt circle diameter = damper size + flange width + 1/4" (6).

Damper Size (Inside Diameter)	No. of Holes	Degrees Between Holes	Hole/Slot Dimensions
4" (102) thru 6" (152)	4	90	3/8" (10)
> 6" (152) thru 10" (254)	6	60	3/8" (10)
> 10" (254) thru 14" (356)	8	45	3/8" (10)
> 14" (356) thru 20" (508)	10	36	3/8" (10) x 1/2" (13)
> 20" (508) thru 28" (711)	12	30	3/8" (10) x 1/2" (13)
> 28" (711) thru 36" (914)	16	22 1/2	3/8" (10) x 1/2" (13)
> 36" (914) thru 42" (1067)	18	20	9/16" (14) x 11/16" (17)
> 42" (1067) thru 48" (1219)	20	18	9/16" (14) x 11/16" (17)
> 48" (1219) thru 58" (1473)	24	15	9/16" (14) x 11/16" (17)
> 58" (1473) thru 72" (1829)	30	12	9/16" (14) x 11/16" (17)

This chart indicates Nailor's standard bolt hole sizes and configurations for round dampers ordered with Option BH. Non-standard hole sizes and configurations can be provided if required (a clearly detailed drawing of non-standard requirements must be provided to Nailor).

## SQUARE AND RECTANGULAR DAMPERS:

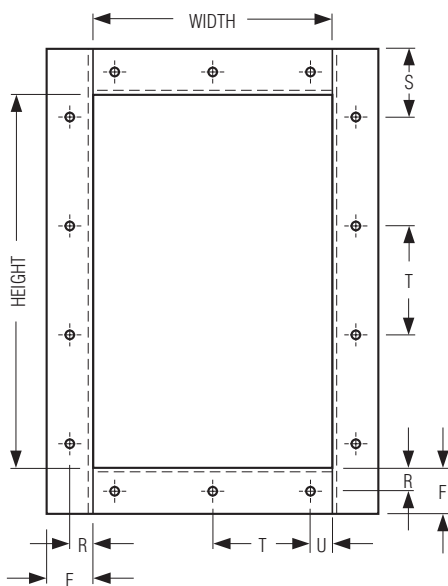

Dimension	Standard	Minimum	Maximum
F	2" (51)	1 1/2" (38)	4" (102)
R	1" (25)	F ÷ 2	F - 3/4" (19)
S	1" (25)	F ÷ 2	-
T	6" (152)	2" (51)	12" (305)
U	-	3/4" (19)	-

This chart indicates Nailor's standard bolt hole configurations for square and rectangular dampers ordered with Option BH. Standard bolt hole size is 7/16" (11) diameter. Non-standard hole sizes and configurations can be provided if required (a clearly detailed drawing of non-standard requirements must be provided to Nailor).

SCHEDULE TYPE:

PROJECT:

ENGINEER:

CONTRACTOR:

Dimensions are in inches (mm).

DATE

B SERIES

SUPERSEDES

DRAWING NO.

9 - 9 - 03

1900

NEW

1900BH-1