



HEAVY DUTY INDUSTRIAL CONTROL DAMPERS
STEEL • VEE BLADE
MODELS: 1910 & 1920
1917 & 1927

The Nailor Model Series 1910/1920 is a heavy duty industrial control damper designed for use in medium to high pressure industrial HVAC or process air systems. Features include a vee-blade design that offers precise airflow control or shut-off in applications involving pressure differentials of up to 8.5" w.g. depending on width, and velocities up to 3000 fpm.

Models 1917/1927 feature 3/4" (19) dia. axles and are suitable for applications of up to 20" w.g. pressure differential depending on damper width, and velocities up to 3500 fpm.

The heavy duty flanged frame, with optional bolt holes, connects easily to flanged duct for fast, secure installation. Model Series 1910/1920 may be used for two-position or modulating control utilizing a selection of electric or pneumatic actuators, or can be operated manually with the optional locking hand quadrant.

STANDARD CONSTRUCTION:

- FRAME:** 8" x 2" x 14 ga. (203 x 51 x 2) coated steel channel.
- BLADES:** Approx. 6" (152) wide on 5 1/2" (140) centers, up to 8 5/8" (219) wide maximum depending on size. 16 ga. (1.6) galvanized steel vee-blade design. Parallel or opposed action.
- LINKAGE:** Heavy duty side linkage, concealed out of the airstream.
- AXLES:** Models 1910/1920: 1/2" (13) dia. plated steel. Models 1917/1927: 3/4" (19) dia. plated steel. Axles are double bolted to blades.
- BEARINGS:** Stainless steel sleeve type.
- DRIVE SHAFT:** 1/2" (13) or 3/4" (19) dia. (see AXLES above) plated steel. Extends 6" (152) beyond frame.
- MINIMUM SIZE:** Single blade: 6" x 6" (152 x 152). Two blades (parallel or opposed): 6" x 10" (152 x 254).
- MAXIMUM SIZE:** 48" x 96" (1220 x 2438). For larger sizes, contact factory.
- MAXIMUM TEMPERATURE:** 250°F (121°C) standard. 400°F (204°C) with increased blade/frame clearance (Option code HT).
- MAX. PRESSURE:** Models 1910/1920: 2.5 to 8.5" w.g. (see page 2). Models 1917/1927: 6.5 to 20" w.g. (see page 2).
- MAX. VELOCITY:** Models 1910/1920: 3000 fpm (see page 2). Models 1917/1927: 3500 fpm (see page 2).

OPTIONS:

- BH Bolt holes in flanges
- BPV PVC blade seals (up to 180°F (83°C))
- BSS Silicone blade seals (up to 400°F (204°C))
- JSS Stainless steel jamb seals
- BEB External bolt-on bearings
- BEBS External bolt-on bearings with seal
- BOS Outboard bearings with seal
- 12GF 12 ga. frame
- 14GB 14 ga. blades
- 304 Stainless steel construction

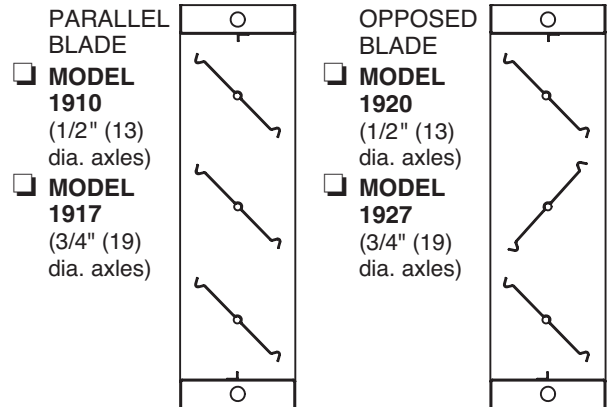
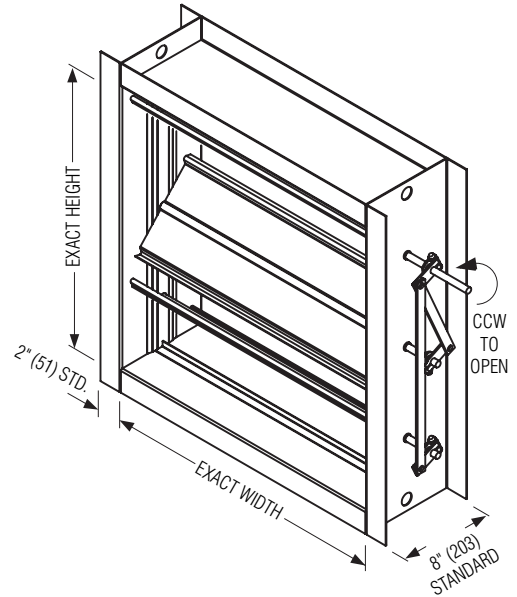

OPTIONS (continued):

- SSA 304 stainless steel axles only
- HT High temp. (up to 400°F (204°C)) blade/frame clearance
- NSF Non-standard flange width (1 1/2" (38) to 4" (102)). Specify _____.
- HDLQ Locking hand quadrant
- FMA Factory mounted actuator. Specify _____.
- Special _____.

Note: For variations not shown, contact factory.

SCHEDULE TYPE:	Page 1 of 2			
PROJECT:	Dimensions are in inches (mm).			
ENGINEER:	DATE	B SERIES	SUPERSEDES	DRAWING NO.
CONTRACTOR:	3 - 30 - 06	1900	7 - 29 - 04	1910



HEAVY DUTY INDUSTRIAL CONTROL DAMPERS STEEL • VEE BLADE PERFORMANCE DATA MODELS: 1910/1920 & 1917/1927

PERFORMANCE LIMITATIONS:

Damper Width	Models 1910/1920		Models 1917/1927	
	Max. System Pressure	Max. System Velocity	Max. System Pressure	Max. System Velocity
48" (1219)	2.5 in. w.g.	3000 fpm	6.5 in. w.g.	3500 fpm
36" (914)	4.0 in. w.g.	3000 fpm	9.0 in. w.g.	3500 fpm
24" (610)	6.0 in. w.g.	3000 fpm	15.0 in. w.g.	3500 fpm
12" (305)	8.5 in. w.g.	3000 fpm	20.0 in. w.g.	3500 fpm

Pressure and velocity limitations shown are guidelines for design purposes. Although ratings are on the conservative side, contact Nailor for requirements beyond limitations shown.

LEAKAGE:

Damper Width	Models 1910/1920				Models 1917/1927			
	Leakage w/o Seals		Leakage with Seals		Leakage w/o Seals		Leakage with Seals	
	CFM per Sq. Ft.	% of Max. Flow	CFM per Sq. Ft.	% of Max. Flow	CFM per Sq. Ft.	% of Max. Flow	CFM per Sq. Ft.	% of Max. Flow
48" (1219)	31.5	1.05	4.2	0.14	31.5	0.90	4.2	0.12
36" (914)	31.5	1.05	4.2	0.14	31.5	0.90	4.2	0.12
24" (610)	39.0	1.30	8.5	0.28	39.0	1.12	8.5	0.24
12" (305)	59.0	1.97	13.0	0.43	59.0	1.69	13.0	0.37

Leakage data is based upon a pressure differential of 1 in. w.g., tested in accordance with AMCA Standard 500-D, Figure 5.5. For pressure differentials greater than 1 in. w.g. apply the appropriate leakage correction factor from the following chart:

Static Pressure (in. w.g.)	2	3	4	5	6	7	8	9	10	12	14	16	18	20
Correction Factor	x 1.4	x 1.7	x 2.0	x 2.2	x 2.4	x 2.6	x 2.8	x 3.0	x 3.2	x 3.5	x 3.7	x 4.0	x 4.2	x 4.5

PRESSURE DROP: SIZE: 36" x 36" (914 x 914)

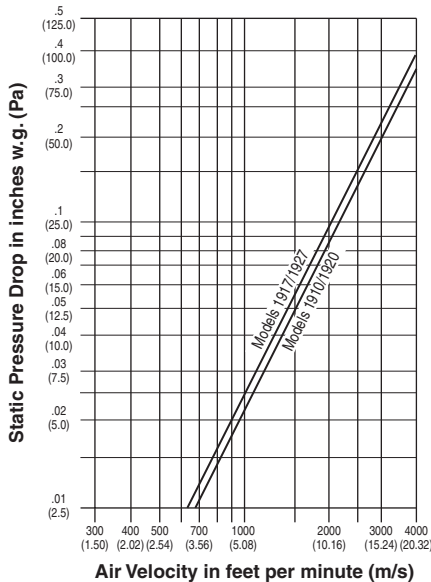

Tested per AMCA Standard 500-D using test set-up figure 5.3, ductwork upstream and downstream.

SCHEDULE TYPE:	Page 2 of 2 Dimensions are in inches (mm).			
PROJECT:				
ENGINEER:	DATE	B SERIES	SUPERSEDES	DRAWING NO.
CONTRACTOR:	3 - 30 - 06	1900	7 - 29 - 04	1910