



HEAVY DUTY INDUSTRIAL CONTROL DAMPER

ROUND • STEEL

MODEL: 1990

The Nailor Model 1990 is a heavy duty, butterfly type damper designed for use in medium pressure industrial HVAC or process air systems. The model offers precise airflow control or shut-off in applications involving 6" w.g. or higher pressure differentials and velocities up to 6000 fpm, depending on unit size. The heavy duty flanged frame, with optional bolt holes, connects easily to flanged duct for fast, secure installation. Model 1990 may be used for two-position or modulating control utilizing a variety of electric or pneumatic actuators, or can be operated manually with the optional locking hand quadrant.

STANDARD CONSTRUCTION:

- FRAME:** Steel channel. See chart below for thickness, depth and flange dimensions.
- BLADE:** Steel, reinforced as required. See chart below for thickness.
- BEARINGS:** Stainless steel sleeve type.
- AXLE:** Plated steel, continuous, reinforced as required. See chart below for diameter.
- DRIVE SHAFT:** Continuous axle extends approx. 6" (152) beyond frame.
- BLADE STOP:** Single tab, welded to frame.
- FINISH:** Grey epoxy paint.
- AVAILABLE SIZES:** 4" (102) through 60" (1524) diameter.
- MAXIMUM TEMPERATURE:** 250°F (121°C) standard. 400°F (204°C) with increased blade/frame clearance (Option code HT).
- MAX. PRESSURE:** 6 to 10" w.g. (see page 2).
- MAX. VELOCITY:** 4000 to 6000 fpm (see page 2).

OPTIONS:

- BH Bolt holes in flanges
- BEB External bolt-on bearings
- BEBS External bolt-on bearings with seal
- BOS Outboard bearings with seal
- PBS Perimeter blade stop
- BSN Neoprene blade seal (up to 250°F (121°C))
- BSS Silicone blade seal (up to 400°F (204°C))
- 304 Stainless steel construction
- SSA 304 stainless steel axles only
- HT High temp. (up to 400°F (204°C)) blade/frame clearance
- HDLQ Locking hand quadrant
- FMA Factory mounted actuator. Specify _____.
- Special _____.

Note: For variations not shown, contact factory.

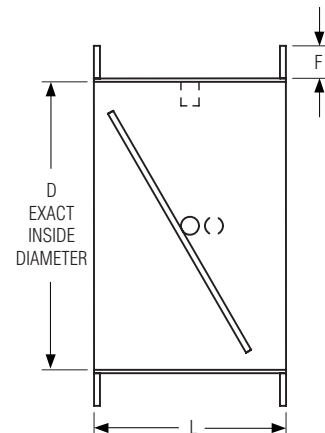
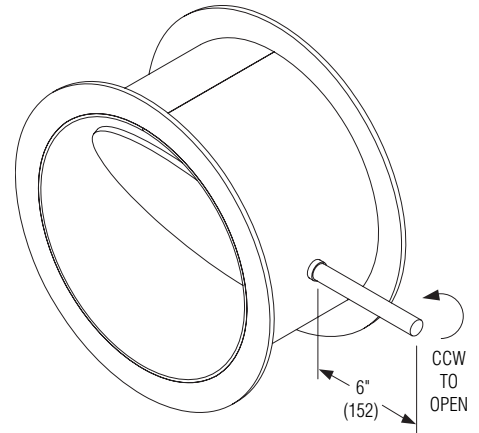

Size (Inside Diameter 'D')	Frame Depth (L) x Thickness	Flange Width (F) x Thickness	Blade Thickness	Axle Diameter
4" (102) to < 8" (203)	6" (152) x 10 ga.	1 1/4" (32) x 10 ga.	10 ga.	1/2" (13)
8" (203) to < 12" (305)	8" (203) x 10 ga.	1 1/4" (32) x 10 ga.	10 ga.	1/2" (13)
12" (305) to < 16" (406)	8" (203) x 10 ga.	1 1/2" (38) x 10 ga.	10 ga.	1/2" (13)
16" (406) to < 24" (610)	8" (203) x 10 ga.	1 1/2" (38) x 1/4" (6)	10 ga.	3/4" (19)
24" (610) to < 42" (1067)	8" (203) x 10 ga.	2" (51) x 1/4" (6)	3/16" (5)	3/4" (19)
42" (1067) to < 48" (1219)	8" (203) x 10 ga.	2" (51) x 1/4" (6)	3/16" (5)	1" (25)
48" (1219) to 60" (1524)	8" (203) x 3/16" (5)	2 1/2" (64) x 5/16" (8)	1/4" (6)	1" (25)

SCHEDULE TYPE:

PROJECT:

ENGINEER:

CONTRACTOR:

Page 1 of 2
Dimensions are in inches (mm).

DATE

B SERIES

SUPERSEDES

DRAWING NO.

10 - 4 - 07

1990

3 - 30 - 06

1990



HEAVY DUTY INDUSTRIAL CONTROL DAMPER ROUND • STEEL MODEL: 1990

PERFORMANCE LIMITATIONS:

Diameter	12" (305)	24" (610)	36" (914)	48" (1219)	60" (1529)
Maximum System Pressure	10.0" w.g.	8.0" w.g.	8.0" w.g.	6.0" w.g.	6.0" w.g.
Maximum System Velocity	6000 fpm	6000 fpm	5000 fpm	4000 fpm	4000 fpm

PRESSURE DROP:

12" (305) Diameter

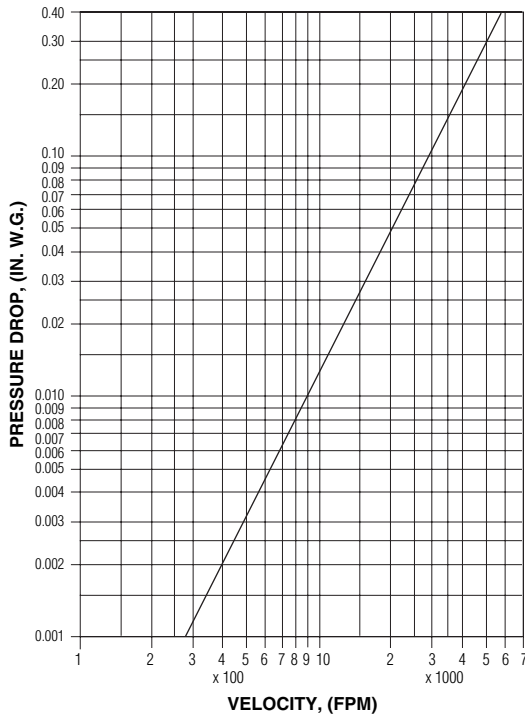

36" (914) Diameter

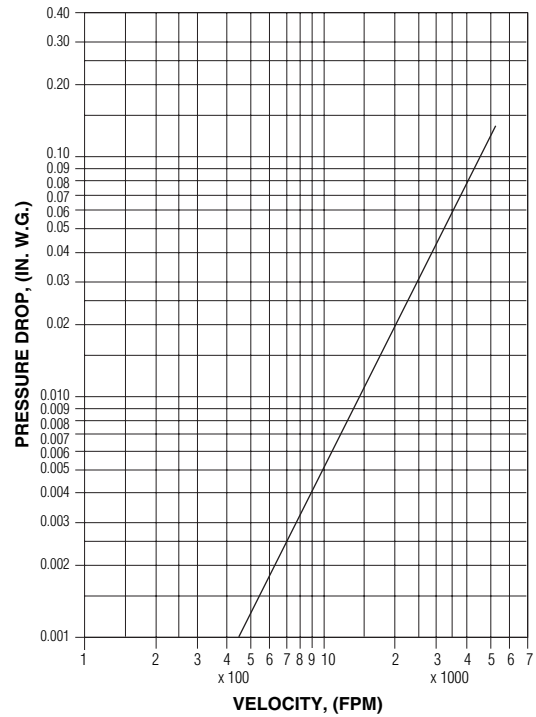

LEAKAGE:

12" (305) Diameter Damper

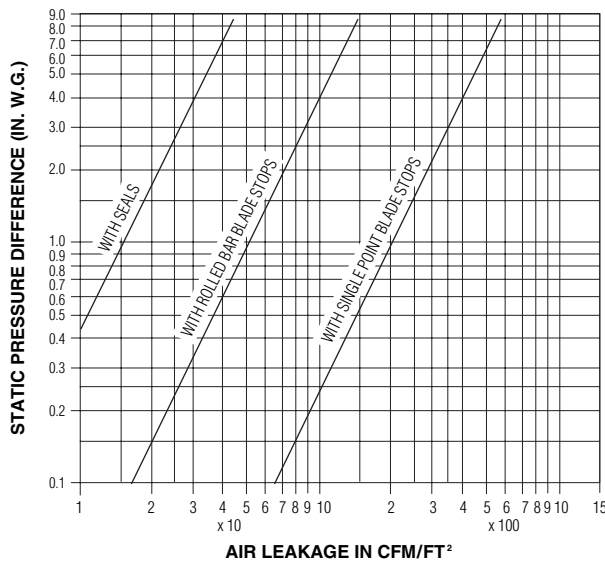

36" (914) Diameter Damper

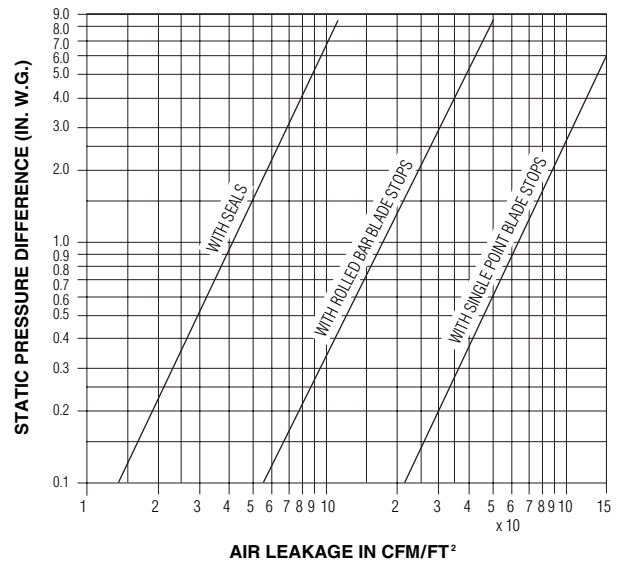

SCHEDULE TYPE:

PROJECT:

ENGINEER:

CONTRACTOR:

Page 2 of 2
Dimensions are in inches (mm).

DATE

B SERIES

SUPERSEDES

DRAWING NO.

10 - 4 - 07

1990

3 - 30 - 06

1990