



AIRFOIL CONTROL DAMPER
EXTRUDED ALUMINUM BLADE
ULTRA-LOW LEAKAGE • HIGH PERFORMANCE
MODELS: 2010 & 2020 WITH EAF EXTRUDED
ALUMINUM FRAME OPTION

AMCA LICENSED

The 2000 Series dampers are Nailor's premium choice for use in high velocity, medium pressure commercial and industrial HVAC systems. They offer unsurpassed leakage (Class 1A) and pressure drop characteristics for superior performance that meets the International Energy Conservation Code maximum leakage for building envelope dampers criteria of 3 cfm/ft² @ 1" w.g. (15.2 L/s/m² @ 0.25 kPa). Model 2020 is an AMCA licensed damper bearing the AMCA Air Leakage and Air Performance Seal. Leakage rating is maintained with airflow in either direction, permitting right or left-hand drive installation.

Standard features include no-maintenance concealed linkage and heavy duty extruded aluminum airfoil blades that combine superior rigidity and deflection resistance with low pressure drop. Unique design compression type seals are keyed and locked into blade extrusion, providing the ultimate in ultra-low leakage and high performance. Option EAF provides a heavy duty extruded aluminum hat channel frame with hat mounting flanges.

STANDARD CONSTRUCTION:

- FRAME:** 5" x 7/8" x 0.125" (127 x 22 x 3.2)
Type 6063-T5 extruded aluminum frame.
- BLADES:** Airfoil type 6063-T5 extruded aluminum on 5 1/2" (140) centers.
- LINKAGE:** Concealed side type totally enclosed within the frame and out of the air stream. Plated steel.
- BEARINGS:** 1/2" (13) dia. Oilite® self-lubricating bronze.
- AXLES:** 1/2" (13) dia. plated steel double bolted to blades.
- DRIVE SHAFT:** 6" (152) long x 1/2" (13) dia. lock-on drive shaft on all single section dampers. A 1/2" (13) or 1" (25) dia. factory installed jackshaft is standard on all multiple section dampers. See multi-section detail 2000 MSI.
- BLADE SEALS:** Silicone. Mechanically locked in place.
- JAMB SEALS:** Cambered stainless steel.
- MINIMUM SIZE:** Single blade (parallel) 8" x 8" (203 x 203).
Two blades (parallel or opposed) 8" x 12" (203 x 305).
- MAXIMUM SIZE:** Single section size is 60" x 72" (1524 x 1829).
Multiple section - unlimited.

TEMPERATURE RANGE
 -50°F to 250°F (-45°C to 157°C)

OPTIONS:

- SMP** Side mounting plate for actuator
- BS** Type 304 stainless steel bearings
- SSA** Type 304 stainless steel axles
- SSL** Type 304 stainless steel linkage (includes axles & bearings)
- Other _____.

Nailor offers a wide selection of pneumatic and electric actuators for factory or field installation.

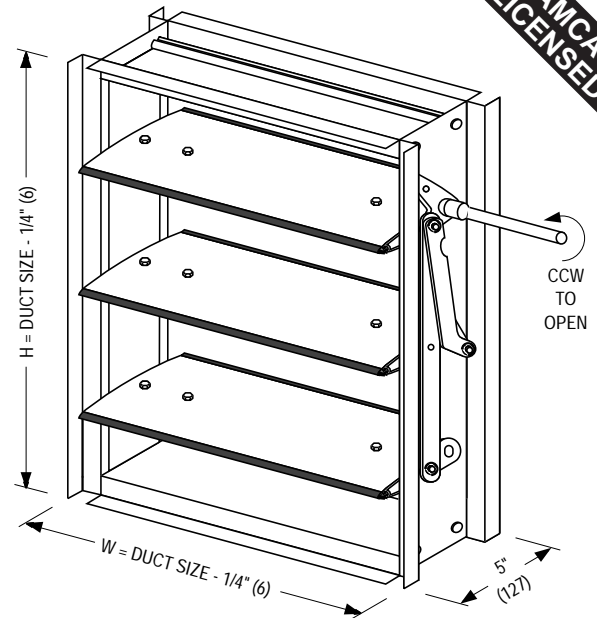

MODEL 2010EAF PARALLEL BLADE
 † jackshaft standard on multiple section dampers. Jackshaft securely bolted to frame.

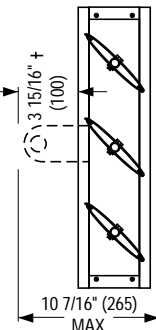

MODEL 2020EAF OPPOSED BLADE

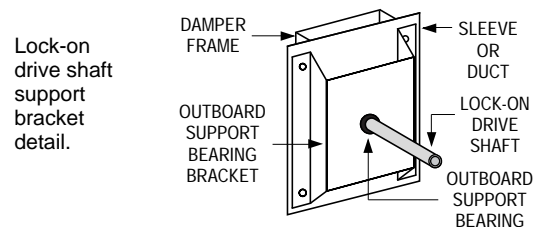
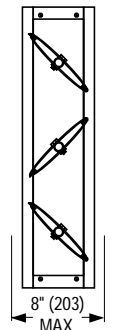

SCHEDULE TYPE:	Dimensions are in inches (mm).			
PROJECT:				
ENGINEER:	DATE	C SERIES	SUPERSEDES	DRAWING NO.
CONTRACTOR:	1 - 16 - 07	2000	3 - 3 - 06	2000-3