

1. Control dampers are classified as follows:

- With Seals: Single-skin Blades - 1010 Parallel, 1020 Opposed  
 Steel Airfoil Blades - 1110 Parallel, 1120 Opposed  
 Aluminum Airfoil Blades - 2010 Parallel, 2020 Opposed

No Seals: Single-skin Blades - 1012 Parallel, 1022 Opposed

Maximum single section size is 48" wide x 72" high (1219 x 1829) for all models except 2000 series which is 60" wide x 72" high (1524 x 1829).

2. Dampers larger than the maximum single section size are fabricated in multiple section assemblies. These assemblies consist of sections of equal size which are coupled together with a jackshaft. The jackshaft runs parallel to the "w" dimension.

A. 1/2" (13) Diameter Jackshaft:

- Used on two sections wide with a maximum of 32 sq. ft. with blade and jamb seals; or a maximum of 40 sq. ft. without seals.

B. 1" (25) Diameter Jackshaft:

- Used on two sections wide over 32 sq. ft. with blade and jamb seals; or over 40 sq. ft. without seals.
- Used on assemblies of more than two sections wide, regardless of area.

Maximum Section Size for all Multiple Section Dampers: 48" wide x 72" high (1219 x 1829).

3. Use the details on page 2 and 3 to determine how multiple section dampers with standard construction and sizes up to 240" wide x 144" high (6086 x 3658) will be manufactured. Details do not apply if the control damper has any of the following non-standard features:

- A. Unequal section sizes.
- B. Face and By-pass arrangement.

For sizes larger than 240" x 144" (6096 x 3658), consult factory.

4. How to determine your damper configuration:

A. Calculate the damper area in square feet:

$$\text{Area} = \frac{(W \text{ in. wide} \times H \text{ in. high})}{144} = \text{_____ sq. ft.}$$

B. Based on the W and H dimensions and the area of your damper, determine the appropriate assembly detail using the chart on page 2.

Example: Model 1020 (with seals) 96" wide x 96" high.

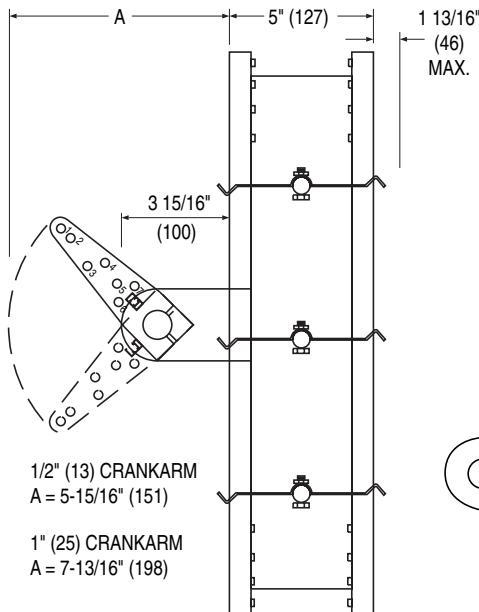
$$\text{Area} = \frac{(96 \times 96)}{144} = 64 \text{ sq. ft.}$$

From chart and drawings, damper configuration is per detail 22Q. Your damper will be built this way.

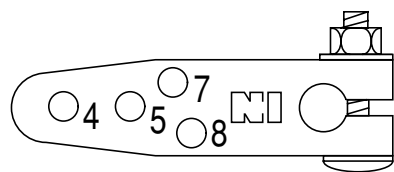
4. Multiple section assemblies require bracing to support the weight of the assembly and to hold against system pressure. Appropriate bracing must support the damper horizontally at least once for every 8 ft.(2438) of damper width. Vertical assemblies and higher system pressures require more bracing.

5. The maximum shipping size is 96" x 72" (2438 x 1829) or two sections wide. Larger units are shipped in sections for field assembly. Refer to the Control Damper Installation Instructions on page 4 for joining multiple sections.

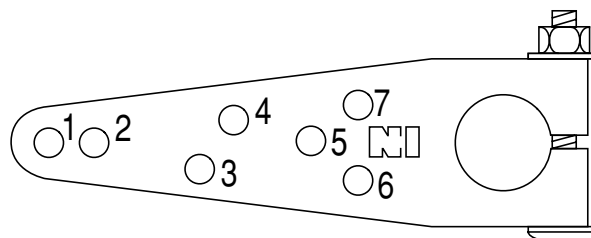
6. The crank arm furnished with 1" (25) dia. jackshaft assemblies is shown below. If needed, order extra crank arms or optional crank arms for 1/2" (13) dia. jackshafts (both at additional cost) by part number.



**CLEARANCE REQUIREMENTS**



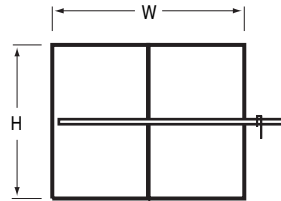
**1/2" (13) DIA. CRANK ARM (OPTIONAL)**  
 PART NO. CD005



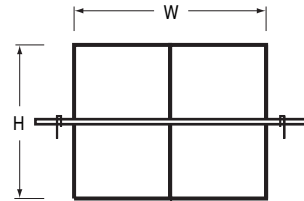
**1" (25) DIA. CRANK ARM**  
 PART NO. CD010

HOLE NO.	CRANK ARM RADIUS
8	1 3/8" (35)
7	1 9/16" (40)
6	1 9/16" (40)
5	2" (51)
4	2 13/16" (72)
3	3 3/16" (81)
2	4 1/4" (108)
1	4 3/4" (121)

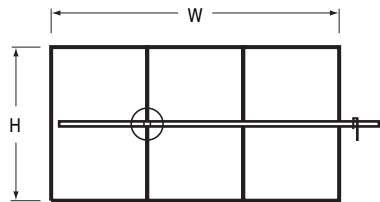
DIMENSION "W" WIDTH IN INCHES (mm)							
DIMENSION "H" HEIGHT IN INCHES (mm) ↓	ALL MODEL SERIES	1000 AND 1100 SERIES ONLY	2000 SERIES ONLY		ALL MODEL SERIES		
	48" (1219) AND UNDER	OVER 48" (1219) THRU 96" (2438)	OVER 48" (1219) THRU 60" (1524)	OVER 60" (1124) THRU 96" (2438)	OVER 96" (2438) THRU 144" (3658)	OVER 144" (3658) THRU 192" (4877)	OVER 192" (4877) THRU 240" (6096)
72" (1829) AND UNDER	-	DETAIL 21 S OR D	-	DETAIL 21 S OR D	DETAIL 31 S OR D	DETAIL 41 S OR D	DETAIL 51 S OR D
OVER 72" (1829) THRU 144" (3658)	DETAIL 12 S OR D	DETAIL 22 S, D OR Q	DETAIL 22 S, D or Q		DETAIL 32 D OR Q	DETAIL 42 D OR Q	DETAIL 52 D OR Q



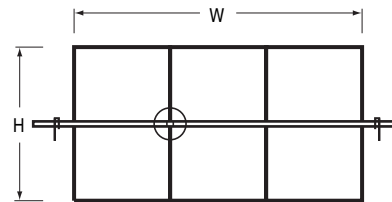
**DETAIL 21S**  
25 SQ. FT. AND UNDER WITH SEALS  
48 SQ. FT. AND UNDER NO SEALS



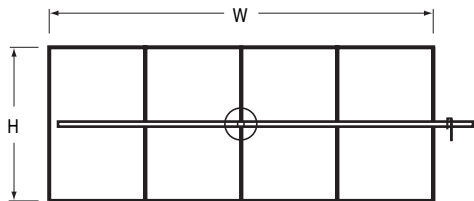
**DETAIL 21D**  
OVER 25 THRU 48 SQ. FT. WITH SEALS



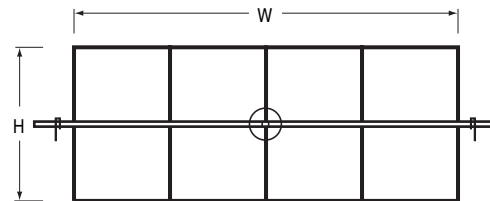
**DETAIL 31S**  
25 SQ. FT. AND UNDER WITH SEALS  
50 SQ. FT. AND UNDER NO SEALS



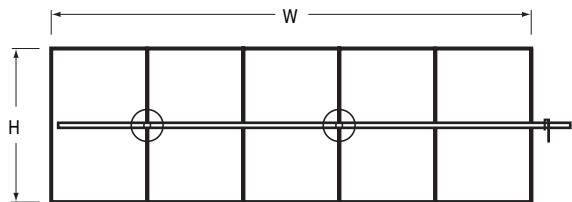
**DETAIL 31D**  
OVER 25 THRU 50 SQ. FT. WITH SEALS  
OVER 50 THRU 72 SQ. FT. NO SEALS



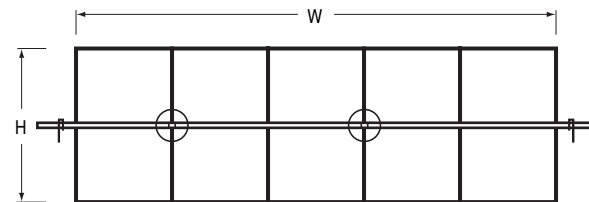
**DETAIL 41S**  
25 SQ. FT. AND UNDER WITH SEALS  
50 SQ. FT. AND UNDER NO SEALS



**DETAIL 41D**  
OVER 25 THRU 96 SQ. FT. WITH SEALS  
OVER 50 THRU 96 SQ. FT. NO SEALS

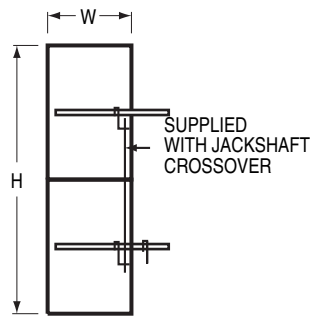


**DETAIL 51S**  
25 SQ. FT. AND UNDER WITH SEALS  
50 SQ. FT. AND UNDER NO SEALS

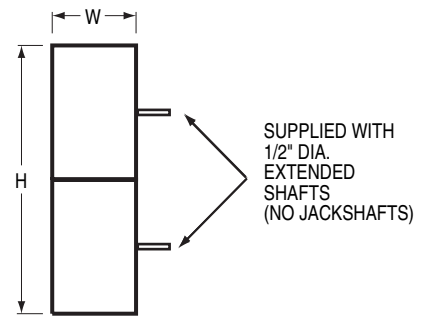


**DETAIL 51D**  
OVER 25 THRU 120 SQ. FT. WITH SEALS  
OVER 50 THRU 120 SQ. FT. NO SEALS

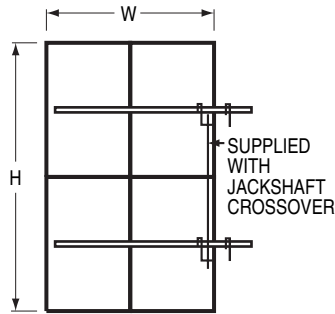
**NOTE:** ⊕ INDICATES LOCATION OF JACKSHAFT COUPLING.



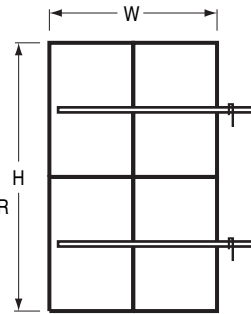
**DETAIL 12S**  
25 SQ. FT. AND UNDER WITH SEALS  
48 SQ. FT. AND UNDER NO SEALS



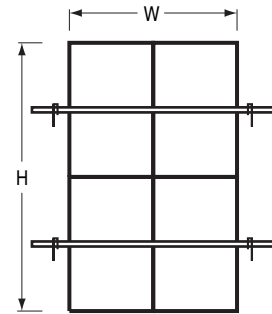
**DETAIL 12D**  
OVER 25 THRU 48 SQ. FT. WITH SEALS



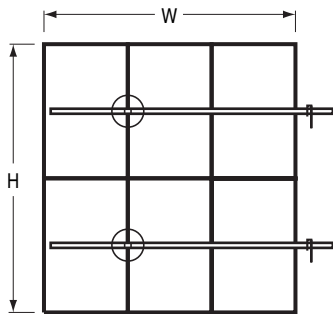
**DETAIL 22S**  
OVER 24 THRU 25 SQ. FT. WITH SEALS  
OVER 24 THRU 50 SQ. FT. NO SEALS



**DETAIL 22D**  
OVER 25 THRU 50 SQ. FT. WITH SEALS  
OVER 50 THRU 96 SQ. FT. NO SEALS

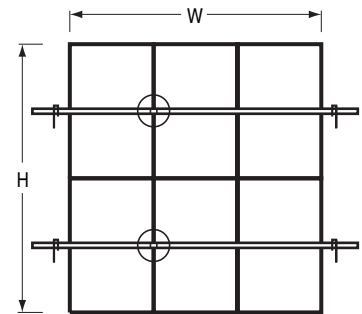


**DETAIL 22Q**  
OVER 50 THRU 96 SQ. FT. WITH SEALS

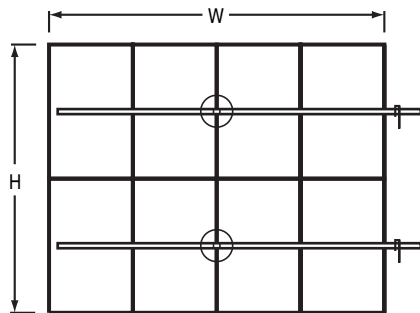


**DETAIL 32D**  
OVER 48 THRU 50 SQ. FT. WITH SEALS  
OVER 48 THRU 100 SQ. FT. NO SEALS

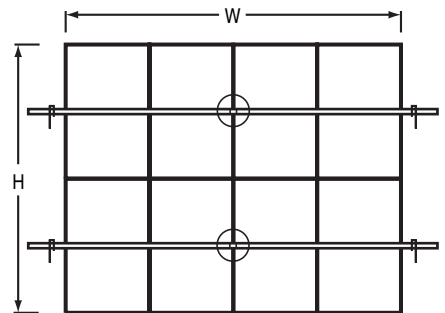
NOTE: INDICATES LOCATION OF JACKSHAFT COUPLING.



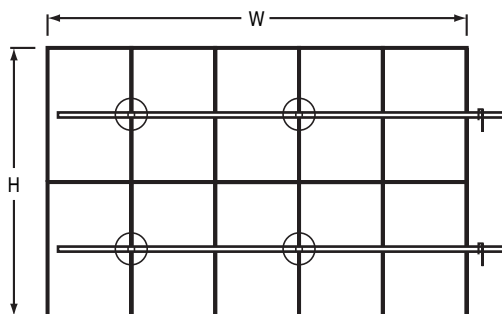
**DETAIL 32Q**  
OVER 50 THRU 144 SQ. FT. WITH SEALS  
OVER 100 THRU 144 SQ. FT. NO SEALS



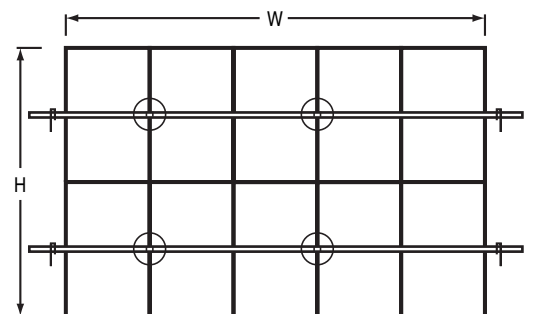
**DETAIL 42D**  
OVER 72 THRU 100 SQ. FT. NO SEALS



**DETAIL 42Q**  
OVER 72 THRU 192 SQ. FT. WITH SEALS  
OVER 100 THRU 192 SQ. FT. NO SEALS



**DETAIL 52D**  
OVER 96 THRU 100 SQ. FT. NO SEALS



**DETAIL 52Q**  
OVER 96 THRU 240 SQ. FT. WITH SEALS  
OVER 100 THRU 240 SQ. FT. NO SEALS

# INSTALLATION INSTRUCTIONS

## RECEIVING/INSPECTION

Upon delivery, inspect shipping containers and dampers carefully. Note any damage on trucker's delivery receipt. Contact the freight company within 24 hours for inspection. Do not install dampers. It is easier to repair on the floor than in the duct.

## STORAGE

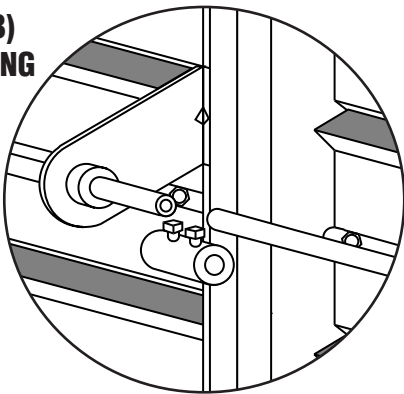
Store in an orderly manner. Do not pile dampers on each other. Cover with plastic sheeting to protect from excessive moisture, dirt and debris. Avoid unnecessary handling of dampers.

## INSTALLATION

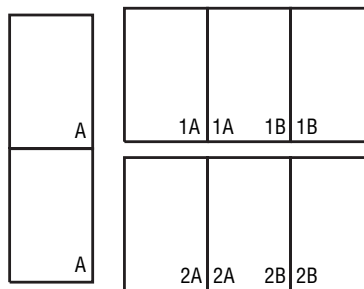
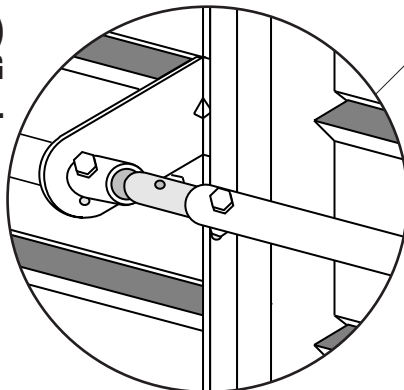
Handle dampers by frame only. Do not lift by blades, linkage, actuator or jackshaft. Use sufficient people to evenly lift multiple section assemblies. Do not drop, drag, step on, or apply excessive bending, twisting or racking. Cycle dampers by hand before installation to ensure freedom of movement.

1. Inspect ductwork or opening where damper will be installed for any obstructions and to ensure it is straight and level. It is essential to support ductwork to prevent sagging due to damper weight.
2. Determine location of extended drive shaft or jackshaft before installation.
3. Position damper shipping sections together in duct or opening. Align and match frame markings on adjacent sections (see fig. 1).
4. Align holes on adjacent frame sections and fasten together on front and back sides with screws or nuts and bolts.
5. Use shims as appropriate between damper frame and duct opening and between damper sections as necessary to prevent distortion of frame by fasteners. Ensure fasteners do not interfere with blade movement or damper linkage. Bracing is required at every horizontal mullion for strength and to support weight. Vertical bracing is recommended at every 8 feet minimum of damper width for strength. Dampers in high velocity and/or high pressure systems require more bracing.
6. If the damper assembly is supplied with unjoined jackshafting and is operated by only one actuator, join jackshaft ends using coupling and set screws or nuts and bolts provided (see fig. 2).
7. If applicable, connect lower and upper jackshafts with the connecting rod crossover supplied, through the swivel on crank arm at each jackshaft. Locate crank arm close to a jackshaft bearing bracket and not centrally in order to minimize play (see fig.2).
8. Ensure dampers are set completely square, plumb and free from racking, twisting or bending and are free to operate without binding (see fig. 3). A clearance must be maintained between blade and blade bearing. Move blade solidly to one side against bearing and measure clearance at other end. If jamb seals are present, compress to determine clearance. Dampers must operate without binding. Before system operation, cycle damper after installation to assure proper operation. On multiple section assemblies, (with jackshaft coupling) all sections should open and close simultaneously.
9. After installation of low leakage dampers with seals, caulk between frame and duct or opening to prevent leakage.

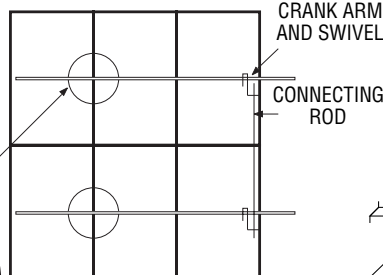
**1/2" (13)  
COUPLING  
DETAIL**



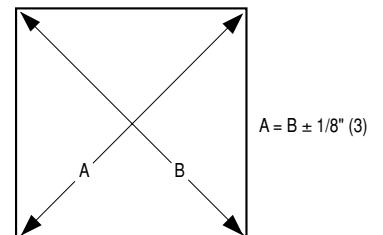
**1" (25)  
COUPLING  
DETAIL**



**FIGURE 1.**

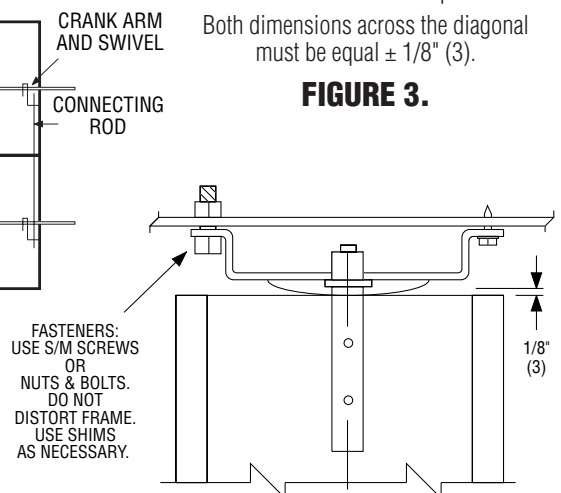


**FIGURE 2.**



Individual damper sections and multiple assemblies must be square. Both dimensions across the diagonal must be equal  $\pm 1/8"$  (3).

**FIGURE 3.**



**FIGURE 4.**