



DYNAMIC CURTAIN TYPE FIRE DAMPER
 1 1/2 HR. LABEL • VERT. OR HORIZONTAL
 FOR USE IN DYNAMIC OR STATIC SYSTEMS
MODEL D0120 TYPE B



QUALIFICATIONS:

- UL 555 Classified Fire Damper. 1 1/2 hr. label. (File # 9492).
- CAN/ULC-S112 Fire Damper Assemblies.
- Meets all the requirements of UL and NFPA 90A for fire dampers in dynamic HVAC systems.
- Meets the requirements for BOCA, SBCCI, UBC, IBC and associated local building codes.
- Meets all the requirements of NBC.
- California State Fire Marshal Listing No. 03225-0935:113.
- City of New York Board of Standards and Appeals. Cal. No. 460-88-SA.
- Maximum velocity 2000 fpm @ 4" w.g.

The D0120 curtain fire damper is UL approved for use where local building codes require the protection of HVAC ductwork penetrations in walls, partitions or floors that have a fire resistance rating of up to 2 hours. The D0120 is classified for use in dynamic "fans on" systems where the HVAC system remains operative in the event of a fire. Damper closure under airflow is assured.

Type B fire dampers place the curtain blade pack out of the airstream for higher free area and reduced pressure drop.

STANDARD SPECIFICATION:

- FRAME:** 4 1/4" (108) wide, 22 ga. (0.85) roll-formed G60 galvanized steel.
- BLADES:** Curtain type interlocking blades, 22 ga. (0.85) roll-formed G60 galvanized steel.
- ENCLOSURE:** 22 ga. (0.85) galvanized steel.
- FUSIBLE LINK:** 165°F (74°C) standard. UL Listed. 212°F (100°C) available.
- BLADE CLOSURE:** Stainless steel closure springs and galvanized steel locking ramps.
- MINIMUM SIZE:** 6" x 4" (152 x 102)
- MAXIMUM SIZE:** Single Section
 Vertical or Horizontal mount: 24" x 21" (610 x 533).
 Multiple Section Assembly
 Vertical mount: 72" x 21" (1829 x 533) or 36" x 45" (914 x 1143). See note 2.
 Horizontal mount: Contact factory.

OPTIONS:

- Non-standard temperature fusible link. Specify _____.
- Pull Tab Release. Permits simple reset of spring loaded damper when access door is located on opposite side of locking ramp. (See dwg. ACC-PTR for details).
- Factory Sleeve. Available in 10 (3.5) through 22 ga. (0.85) galvanized steel and in lengths required for application. Specify : _____ length. _____ ga.

NOTES:

1. See sizing chart for relationship of duct size and damper size. Refer to drawings SC1 and SC2.
2. Individual sections of multiple section assembly not to exceed 18" x 24" (457 x 610).
3. Building code and UL Classification require damper installation in accordance with manufacturer's instructions. Refer to document IOM-FDINST.

Manufactured by members of S.M.W.I.A.

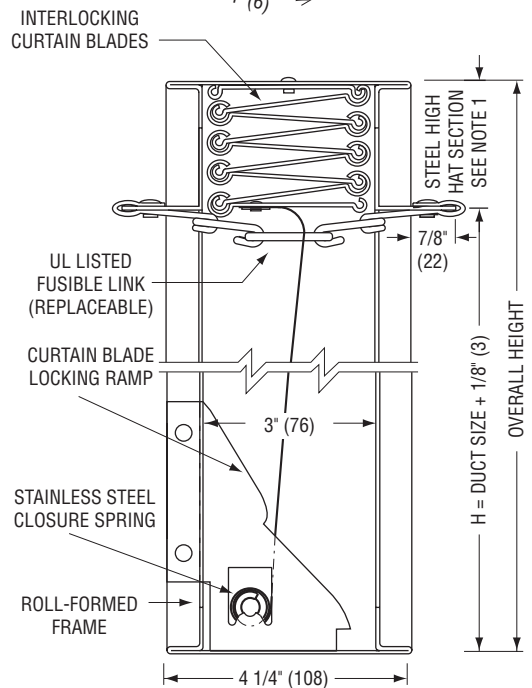
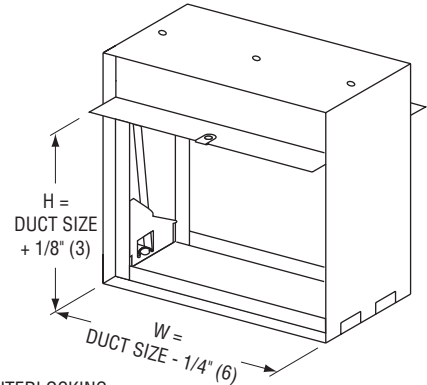

MODEL D0120V – VERTICAL MOUNT

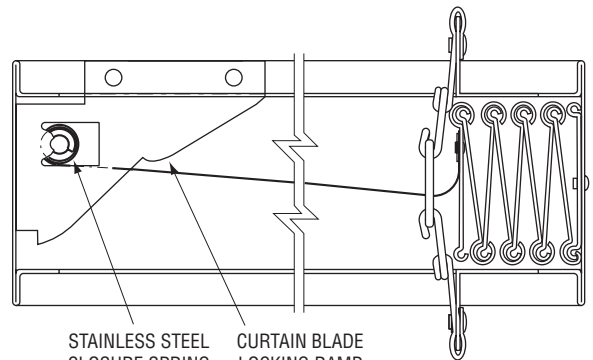

MODEL D0120H – HORIZONTAL MOUNT

Dimensions are in inches (mm).

SCHEDULE TYPE:				
PROJECT:				
ENGINEER:				
CONTRACTOR:				
DATE	B SERIES	SUPERSEDES	DRAWING NO.	
10 - 6 - 06	FD	2 - 16 - 05	D0100-2	