

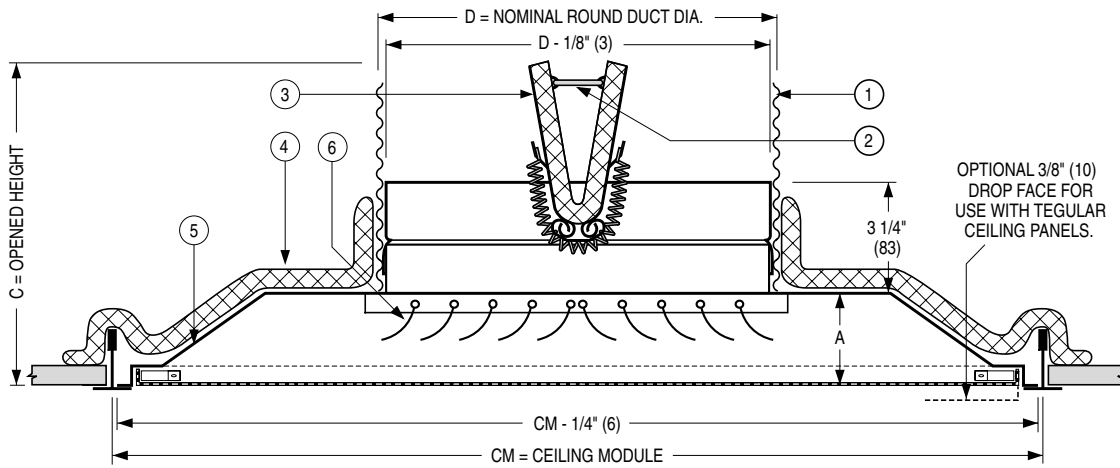

FIRE RATED CEILING DIFFUSER
4-WAY ADJUSTABLE PATTERN •
CURVED BLADES • PERFORATED FACE •
STEEL • ROUND NECK
MODELS: 4070CB, 4075CB, 4080CB & 4085CB



CATEGORY
BZZU



CATEGORY
40U18.1-1/2A



	Imperial Modules						Metric Modules		
	Imperial Units (inches)			SI Units (mm)			SI Units (mm)		
Listed Neck Size	CM = 12 x 12			CM = 305 x 305			CM = 300 x 300		
	D	A	C	D	A	C	D	A	C
	6		6 3/8	152	48	162	152	48	162
8	1 7/8	7 3/8	203	48	187	203	48	187	
Listed Neck Size	CM = 24 x 24			CM = 610 x 610			CM = 600 x 600		
	D	A	C	D	A	C	D	A	C
	6		6 7/8	152		175	152		175
	8		7 7/8	203		200	203		200
	10	2 3/8	8 7/8	254	60	225	254	60	225
	12		9 7/8	305		251	305		251
14		10 7/8	356		276	356		276	

- MODEL 4070CB FLUSH FACE**
- MODEL 4075CB DROP FACE**
12 x 12 (300 x 300) module
Adjustable Curved Blades
Type L Lay-in Frame
- MODEL 4080CB FLUSH FACE**
- MODEL 4085CB DROP FACE**
24 x 24 (600 x 600) module
Adjustable Curved Blades
Type L Lay-in Frame

ITEMS:

- Flexible air duct (UL/ULC Class 0 or 1) connector or steel duct.
- U.L. Listed fusible link. 212°F (100°C) standard.
- Ceiling radiation damper/fire stop flap.
- Ceramic fibre thermal blanket.
- Corrosion resistant steel diffuser.
- Individually adjustable curved blade deflectors.

DESCRIPTION:

- All models are classified for use in UL/ULC restrained or unrestrained floor/ceiling and or roof/ceiling assemblies which incorporate an exposed grid suspended ceiling (lay-in T-bar) with up to a 3 hour rating. For details of fire rated assemblies, see the current UL Fire Resistance Directory or ULC List of Equipment and Materials Vol. III Fire Resistant Ratings.
- The pattern deflectors can vary the discharge pattern from full horizontal to vertical, and can be used to damper the air volume or close off one or more discharge directions. They may be adjusted by dropping the perforated face and moving the deflectors before or after installation. Removable face has concealed latches for easy access.

- Excellent for VAV systems.
- The perforated face has 3/16" (5) dia. holes on 1/4" (6) staggered centres.
- Standard finish is AW Appliance white.

OPTIONS:

- AV Fusible link adjustable volume control (Model 0722A damper).
- Non-standard temperature U.L. Listed fusible link.
 - 165°F (74°C) 286°F (141°C)
- Finish:
 - SP Special
 - BA Black back pan and deflectors with an appliance white face.
 - BW Black back pan and deflectors with an off-white face.

For installation instructions, see drwgs. 4000-1A and 1B or 4000-2A and 2B.

Dimensions are in inches (mm).

SCHEDULE TYPE:				
PROJECT:				
ENGINEER:	DATE	B SERIES	SUPERSEDES	DRAWING NO.
CONTRACTOR:	19 - 4 - 99RR	4000	4 - 28 - 97	4000-6B