

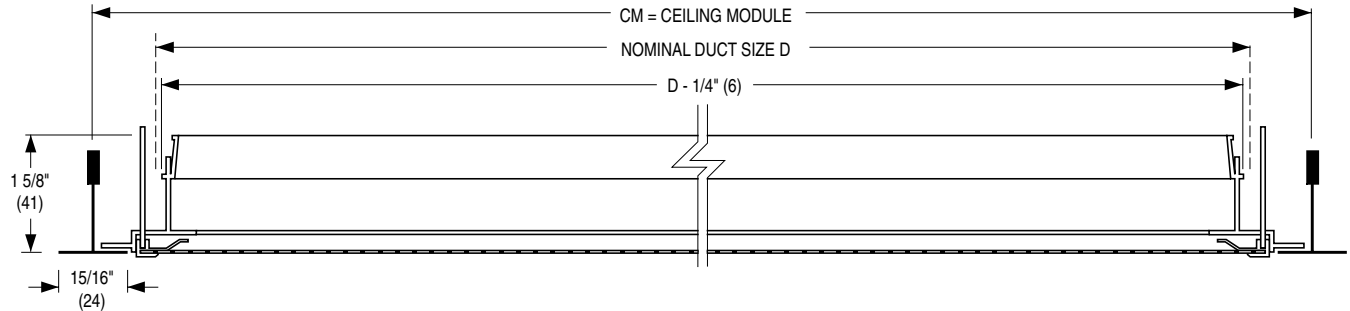

**PERFORATED CEILING DIFFUSER**  
 RETURN • PREMIUM ARCHITECTURAL QUALITY  
 SQUARE NECK (FULL SIZE)  
**MODELS: 4330R, 4330RA**

**TYPE L Lay-in T-Bar**



**Imperial Module & Metric Module Table**

Ceiling Module CM		Nominal Duct Size D	
Imperial Modules	Metric Modules	Square Neck	
		Imperial Modules (in.)	Metric Modules (mm)
12 x 12	300 x 300	10 x 10	250 x 250
24 x 12	600 x 300	22 x 10	550 x 250
20 x 20	500 x 500	18 x 18	450 x 450
24 x 24	600 x 600	22 x 22	550 x 550
48 x 24	1200 x 600	46 x 22	1150 x 550

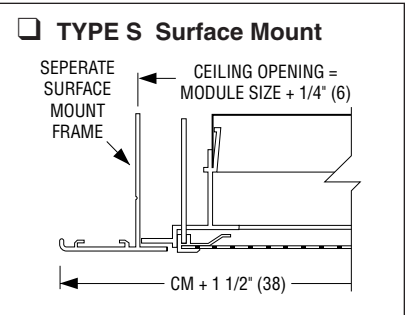

**DESCRIPTION:**

1. Material: Extruded aluminum border frame. Corrosion-resistant steel perforated face.
2. Designed to match supply air Model 4330 in appearance, except that the air pattern controllers are omitted. The diffuser features a mitered corner aluminum frame that encapsulates the perforated face providing a narrow, visible border within the T-bar module. This version is for ducted or ductless return air applications. Features a dedicated frame assembly which has a neck that is 2" (51) less than the ceiling module size for maximum free area.
3. Removable face has quick release spring latches for easy access to optional damper.
4. Perforated face has 3/16" (5) diameter holes on 1/4" (6) staggered centers.
5. Standard finish is AW Appliance White.

**OPTIONS:**

- Aluminum perforated face. (Model 4330RA).  
Finish: \_\_\_\_\_
- SP Special \_\_\_\_\_

<b>SCHEDULE TYPE:</b>		Dimensions are in inches (mm).			
<b>PROJECT:</b>					
<b>ENGINEER:</b>	<b>DATE</b>	<b>B SERIES</b>	<b>SUPERSEDES</b>	<b>DRAWING NO.</b>	
<b>CONTRACTOR:</b>	8 - 24 - 02	4300	1 - 6 - 99R	4330R-1	