

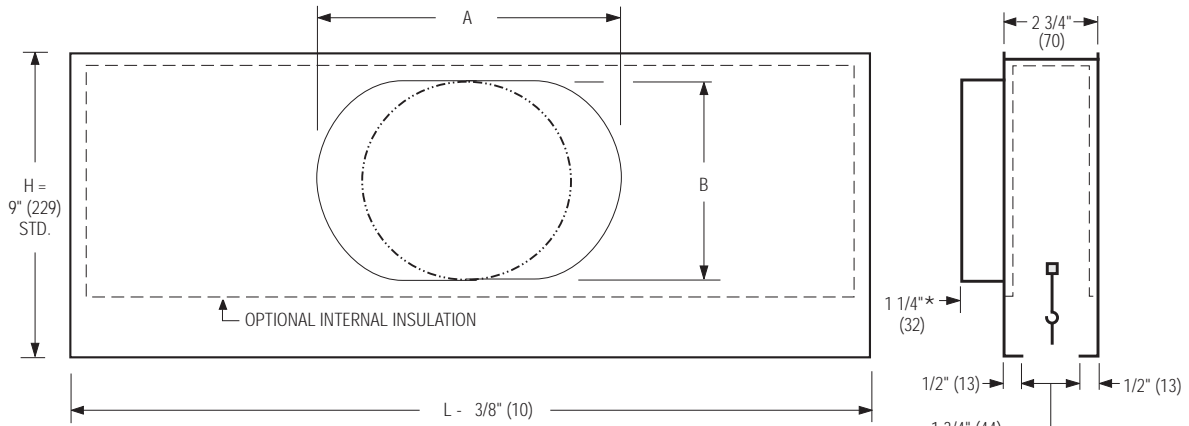

BS SERIES PLENUM SLOT DIFFUSERS
SUPPLY • PREMIUM PERFORMANCE
ADJUSTABLE VERTICAL DISCHARGE
MODEL: 59BS(I)



* 4" (102) with optional ID Inlet Damper

Nominal Length L		Available Inlet Sizes
Imperial Modules	Metric Modules	
24 (610)	600	6, 8, 10, (152, 203, 254)
36 (914)	900	
48 (1219)	1200	
60 (1524)	1500	

Nominal Inlet Size	Dimension (H9)	
	A	B
6 (152) Round	—	5 7/8 (149)
8 (203) Oval	9 (229)	5 7/8 (149)
10 (254) Oval	12 1/8 (308)	5 7/8 (149)

DESCRIPTION:

1. The 59BS Plenum Slot Ceiling Diffusers have been designed for standard lay-in T-Bar application.
2. The 59BS design provides premium performance in perimeter curtain wall applications. An extruded aluminum pattern controller provides an adjustable vertical discharge along the wall or glass in perimeter applications.
3. The design is excellent for VAV, heating and cooling applications.
4. Standard nominal lengths are 24", 36", 48" and 60" to suit imperial ceiling grids. Metric units are available. Standard H9 plenum height is 9" (229). Standard inlet sizes are 6" round, 8" and 10" flat oval.
5. Plenum is corrosion resistant steel.
6. Finish: BK Black pattern controllers and exposed edges.

OPTIONS:

1. Internal Insulation. Model 59BSI
2. ID Inlet Damper
3. PF Plaster Frame
4. Supplementary T-Bars
 - T1 One (inlet side)
 - T0 One (opposite inlet side)
 - T2 Two (Both sides)
5. Mounting Clips
 - M1 One side (2 opposite inlet side)
 - M2 Both sides (4)
6. EX External Foil Back Insulation
7. EQT Earthquake Tabs
8. EC 3" (76) Extended inlet collar w/bead
9. Non-standard plenum height
 - H7 7" (178) high
 - H11 11" (279) high
10. FS Diamond Flow Sensor w/extended collar bead. Requires H11 option. 6" and 8" round inlet sizes only. (Not available on models with internal insulation).
11. SP Special features _____

SCHEDULE TYPE:		Dimensions are in inches (mm).			
PROJECT:					
ENGINEER:	DATE	B SERIES	SUPERSEDES	DRAWING NO.	
CONTRACTOR:	5 - 11 - 09	5900	12 - 1 - 08	59BS	